

PRODUCTS PERFECT
FOR ATTENTION

产品因重视而完美



TAIMA

ONE-STOP SUPPLIER OF PLASTIC
MOLDING AUTOMATION
塑胶成型自动化一站式供应商

 **台玛 台州台玛自动化科技有限公司**
TAIZHOU TAIMA AUTOMATION TECHNOLOGY CO.,LTD

地址: 浙江省台州市黄岩区南城街道十院路100号
Add: 100 Shiyuan Road, Nancheng Street, Huangyan District, Taizhou City, Zhejiang Province
电话/Tel: 0576-84508999
传真/Fax: 0576-84128286
邮箱/E-mail: zjtmkj@outlook.com
网站/Web: www.zjtmkj.cn



About TAIMA

关于台玛



诚恳 自信 激情
HONEST, CONFIDENT,
PASSIONATE

台州台玛自动化科技有限公司成立于2009年，一直致力于塑胶成型自动化周边设备的研发与创新工作，以一站式服务商的交钥匙工程为基准，不断研发推出国际先进高科技环保产品。

台玛人不懈努力地参与客户新产品方案的试制，协助您更迅速、更经济的推出高附加值的产品，为客户打造一流的自动化工厂，实现双赢的目标，为客户创造更大的财富。

公司坐落于中国模具小镇--台州黄岩，是集研发、制造、品保、销售一条龙的企业。

Taizhou Taima Automation Technology co,LTD, founded in 2009, has been committed to the plastic molding automation equipment research and development work in innovation, based on one-stop service turn-key project, continuously development introduced international advanced high-tech environmental protection products.

Units of unremitting efforts to participate in the scheme the trial production of new products, assist you more quickly and more economic high value-addeproducts, for customers to create the first-class factory automation, realize the goal of win-win, create greater wealth for clients.

The company is located in China mold town-taizhou huangyan, is a collection research and development, manufacturing, quality assurance. sales through train enterprises.

Company CULTURE

企业文化



安全
SAFETY

快乐
FUN

规范
STANDARDIZED

高效
EFFICIENT



BE A CHINESE MACHINE BRAND GLOBAL SERVICES, INTELLIGENT MACHINE 做中国塑机品牌，服务全球塑机智能化

核心价值：安全、快乐！规范、高效。

安全、快乐是企业以追求安全生产为永恒主题，倡导以人为本。

舒心、激励的工作氛围是快乐的保障和前提。

规范、高效体现了企业流程清晰、责任明确、授权充分、管理高效。

Core Values: Safety, Fun! Standardized And Efficient.

Security, business in pursuit of happiness is the eternal theme of safe production, promote people-oriented.

Comfortable, encouraging working atmosphere and premise protection is happy.

Standardized and efficient business process reflects a clear, specific responsibilities, and authority to fully efficient management.

企业愿景：让世界认同台玛

我们的愿景要让产品享誉世界！

Corporate vision: to make the world recognize TaiMa

Our vision to make the product world-renowned!

企业使命：集天下才智，创宏伟事业！

企业的发展离不开人才，人是第一生产力。

我们的使命就是集一流人才，为中国塑机制造工业的发展献出至诚至爱。

Enterprise mission: set the world intelligence, creating great cause!

The development of enterprises without talent, who is the first productive force.

Our mission is to set first-class talent for the development

of China machinery manufacturing industry gave sincere love.

员工素养：人品决定产品，细节决定成败！

员工素养是对每一个员工提出的基本要求，

只有具高素质的团队才能生产高品质的产品。

细节法则要求每一个员工注重工作细节、生活细节、行为细节，

良好的工作细节才能培养良好的工作质量，今天的工作质量就是明天的生活质量。

Employees Literacy: character to the product, details the success!

Staff quality is every employee's basic requirements,

Only with a high quality team to produce high quality products.

Details of the laws require every employee focus on details of the work, details of life, behavioral details, details of the work to develop a good work good quality, the quality of today is tomorrow's quality of life.

Product CATALOG

产品目录

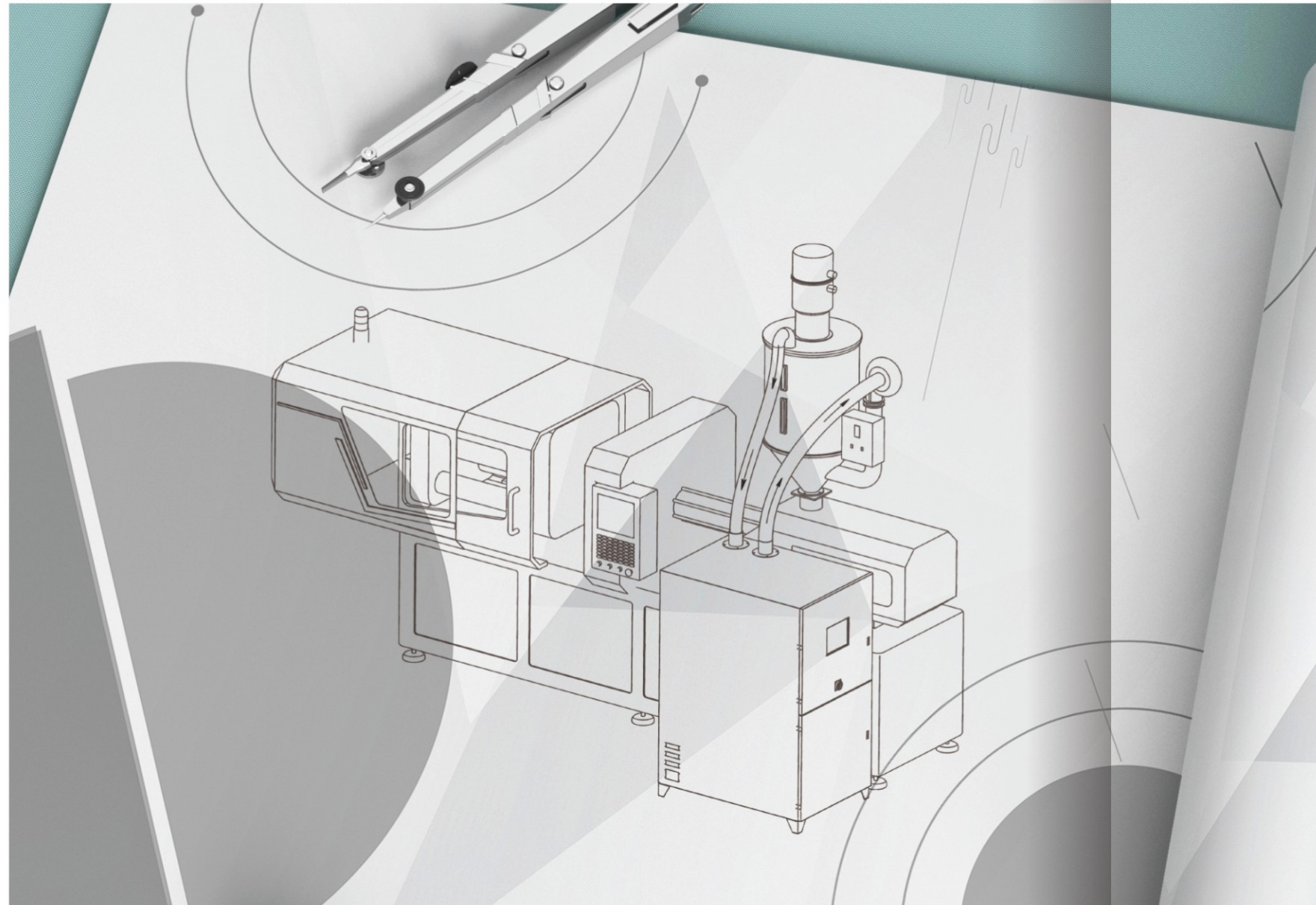

CATALOG

中央供料系统 Central Feeding System	P01
中央供水系统 Central Water Feeding System	P03
300吸料机 300 Auto Loader	P05
800吸料机 800 Auto Loader	P06
欧化吸料机 European Loader	P07
一对多台吸料机 Multi-hopper Loader	P08
热风干燥机 Air-hotted Dryer	P09
欧化干燥机 Euro Design Dryer	P10
大型欧化干燥机 Large European Drying Machine	P11
Pet结晶干燥机 Pet Crystallizer	P13
双机一体欧化干燥机 2-in-1 Euro Design Dryer	P14
除湿机 Dehumidifier Dryer	P15
三机一体除湿机 3-in-1 Dehumidifier	P17
水式冷水机 Water-cooled Chiller	P19
风式冷水机 Air-cooled Chiller	P21
螺杆式冷水机 Screw Chiller	P23
模温机 Mold Heater	P25
强力粉碎机 Heavy Duty Granulator	P27
静音粉碎机 Soundproof Granulator	P29
机边粉碎机 Immediately Recycling Crusher	P31
计量式色母混合器 Volumetric Mixer	P33
容积式比例混合器 Volumetric Mixer	P35
直立式混色机 Vertical Color Mixer	P37
螺杆式混色机 Blending Silo	P38

Central FEEDING SYSTEM

中央供料系统

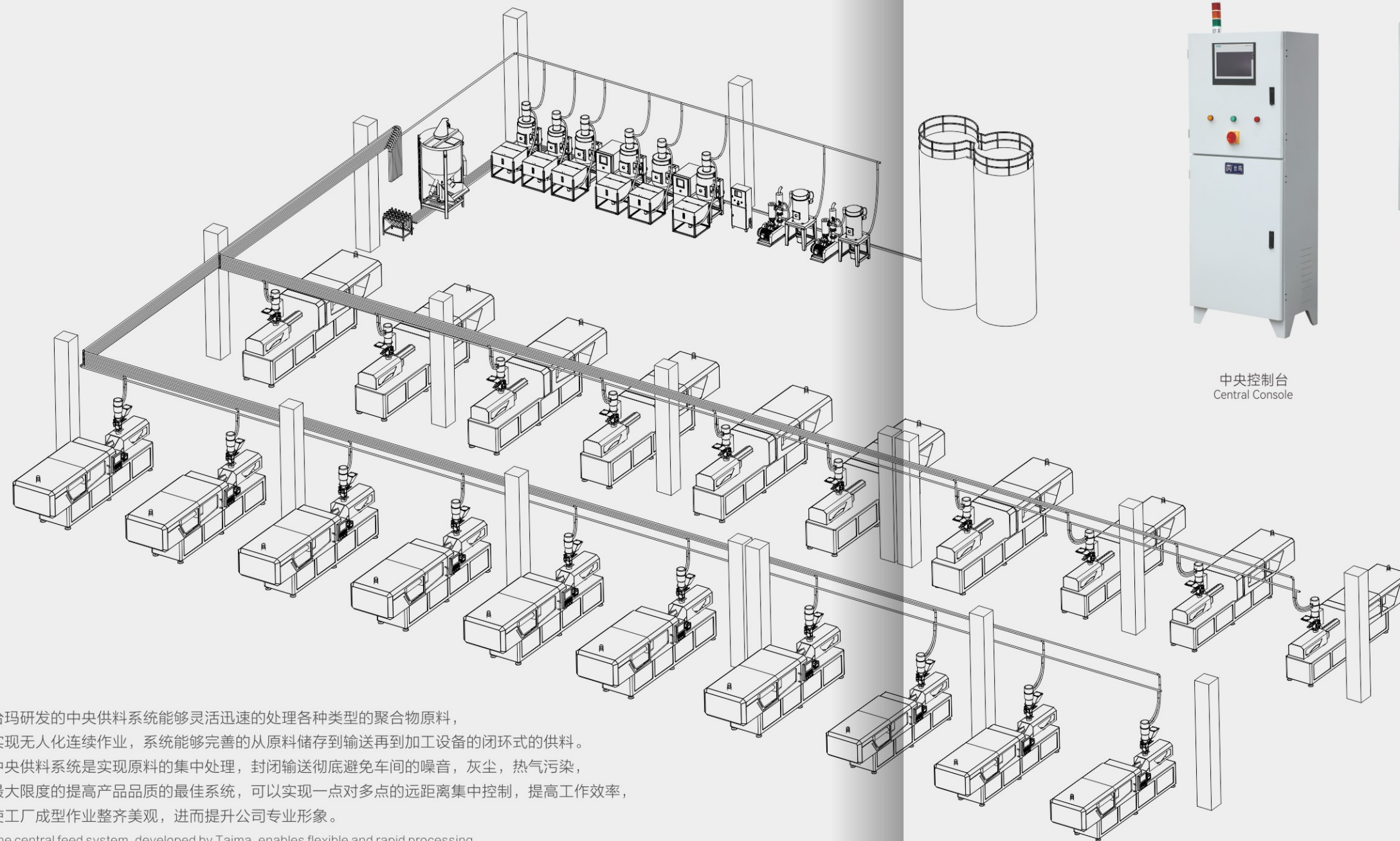

台玛研发的中央供料系统能够灵活迅速的处理各种类型的聚合物原料，实现无人化连续作业，系统能够完善的从原料储存到输送再到加工设备的闭环式的供料。中央供料系统是实现原料的集中处理，封闭输送彻底避免车间的噪音，灰尘，热气污染，最大限度的提高产品品质的最佳系统，可以实现一点对多点的远距离集中控制，提高工作效率，使工厂成型作业整齐美观，进而提升公司专业形象。

The central feed system, developed by Taima, enables flexible and rapid processing of all types of polymer materials, enabling unmanned continuous operation and complete closed-loop feed from material storage to delivery to processing equipment.

The central feeding system is the best system to realize the centralized treatment of raw materials, completely avoid the noise, dust and hot air pollution of the workshop, and maximize the improvement of product quality.

It can realize the remote centralized control of one point to many points and improve the work efficiency.

Make the factory molding operation neat and beautiful, and enhance the company's professional image.



中央控制台
Central Console



中央罗茨风机
Central Roots Fan



原料分配站
Raw Material Distribution Station



中央脉冲集尘器
Central Double Barrel Pulse Dust Collector



可透视欧规料斗
Central Sensor Hopper



中央式欧规磁簧料斗
Central Type Eucalyptus Reed Hopper

Intelligent water and electrical system
智能水电气系统

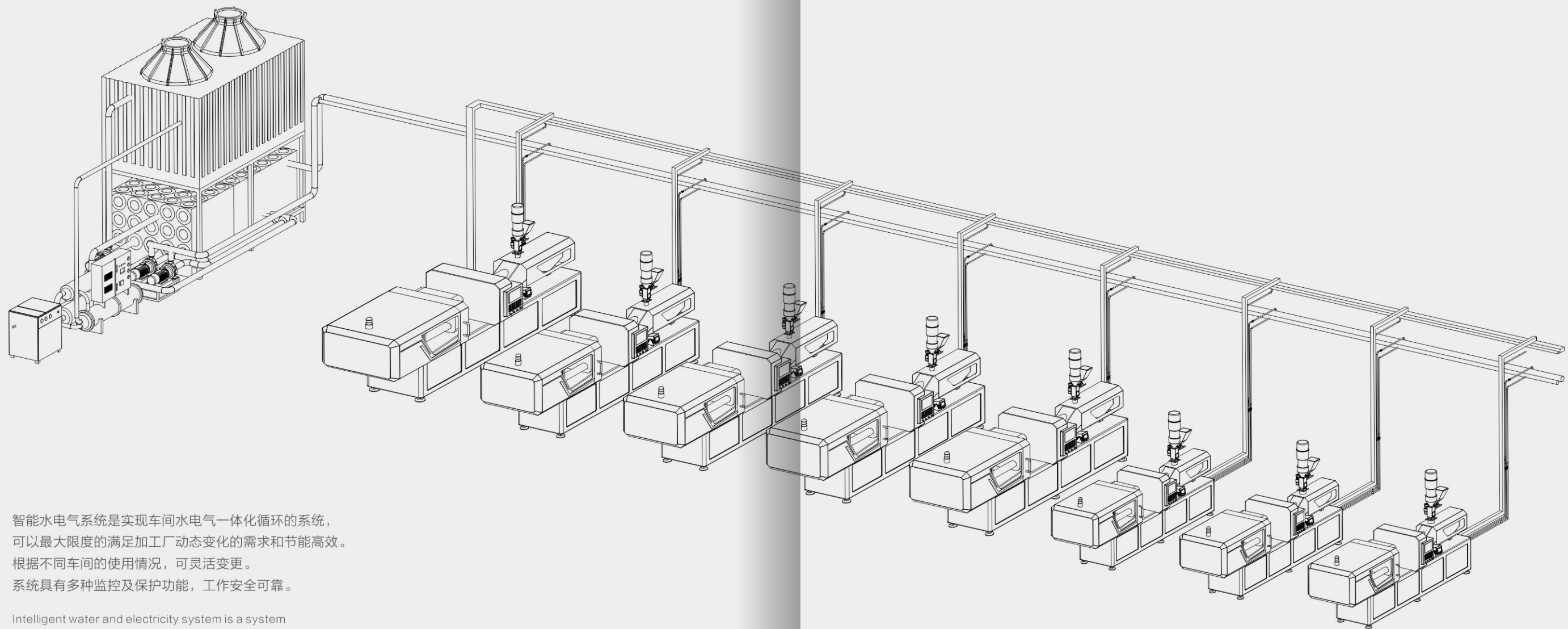

智能水电气系统是实现车间水电气一体化循环的系统，
可以最大限度的满足加工厂动态变化的需求和节能高效。
根据不同车间的使用情况，可灵活变更。
系统具有多种监控及保护功能，工作安全可靠。

Intelligent water and electricity system is a system
that realizes the integrated water and electricity
circulation in the workshop.
It can meet the dynamic changing needs of the processing
plant and save energy and be efficient to the maximum extent.
According to the use of different workshop, flexible change.
The system has a variety of monitoring and protection functions, safe and reliable work.

Auto LOADER 300吸料机



300G



300GM

产品特点

Product Features

- 体积小、重量轻，可直接放置在干燥机或其他原料容器上，完成自动上料工作。
- 微电脑操作控制程序。
- 过载、缺料报警。
- 300G采用高速整流马达、体积小、吸力强，适用于新料输送。
- 首创采用线控器控制，机台下即可设定、控制，方便、快捷。
- 设有空气过滤器(可选件)。
- Small footprint & light, to be placed directly on other machine or container for auto loading.
- Microcomputer controlled.
- Alarm for overload and lack of material.
- High-speed rectificative motor of small footprint and strong suction force for new material for ZD-300G.
- Cable-control, easy to set and control.
- Filter available. With CE authentication.

型号Model		TMAL-300G	TMAL-700G	TMAL-800G	TMAL-800G2
马达 Motor	型式 Type	碳刷式 Carbon brush	碳刷式 Carbon brush	感应式 Induction	感应式 Induction
	规格 Specification	1KW/1.3HP 1Φ	1KW/1.3HP 1Φ	1KW/1.5HP 3Φ	1.5KW/2HP 3Φ
输送能力 (kg/h) Conveying capacity		300	310	450	590
吸料扬程 (m) Loading distance		3.5	4	4	5
静风压 (mm/HO) Static wind pressure		1300	1300	2100	2900
储料桶容量 (L) Reservoir volume		7.5	7.5	7.5	7.5
送料管内径 (mm) Conveying tube inner dim		Φ38	Φ38	Φ38	Φ38
配送料管 (mm) Specification of the attached hoses		Φ38mm x 3.5m 1pcs	Φ38mm x 3.5m 1pcs	Φ38mm x 3.5m 2pcs	Φ38mm x 3.5m 2pcs
外形尺寸 (mm) Dimensions LxWxH	主机 Main frame	340x340x590	340x340x590	420x380x640	500x400x720
	储料桶 Hopper		280x340x430	450x320x450	450x320x450
净重 (kg) Net weight	主机 Main frame	12	14	47	66
	储料桶 Hopper		6	10	10

参数中的输送能力及吸料扬程是以ABS原料为测试材料得出的数据，实际参数根据塑料比重，形状及输送长度、气路高度、管路特性，参数设定等因素而改变。吸料机在输送热料时，料管需选配耐160度高温料管口。

The parameters of the conveying capacity and suction lift are deduced from tests on ABS. The actual parameters may be different due to the specialty of the specific gravity and the shape of the Material.

The conveying distance and height, the specialty of pipeline and the setting of parameters Heat-resistant (160°) pipes should be used when conveying hot material.

Auto LOADER 800吸料机



800G

产品特点

Product Features

- 主机与料斗分体设计，安全、简便。
- 不锈钢料斗。
- 过载、缺料报警。
- 独立滤清装置，方便清除积尘。
- 微电脑操作控制程序。
- 700G采用高速整流马达，体积小、吸力强，适用于新料输送。
- 800G、800G2采用感应式高压风机，噪音小、寿命长。
- 800G、800G2具有逆转自动清除粉尘功能。
- Host machine separated from the hopper, easy and safe to operate.
- Independent filter for easy cleaning.
- Microcomputer controlled.
- Stainless hopper.
- Alarm for overload and lack of material.
- High-speed rectificative motor of small footprint and strong suction force for new material for ZD-800G.
- Induction high-pressure pump of low noise and long service time for ZD-800G&ZD-800G2.
- Reverse cleaning for ZD-800G & ZD-80G2.



除尘料斗
Dust removal hopper



欧规料斗
Eurocode hopper

European LOADER 欧化吸料机

产品特点

Product Features

- 采用微电脑控制、按钮操作，操作界面简洁易懂。
 - 原料输送量大，可实现一对一供料功能。
 - 主机采用高负压风机，体积小安装使用灵活。
 - 分离式的过滤器和集尘桶设计，便于清洁和保养。
 - 指示灯显示工作状态及故障问题。
- Controlled by microprocessor, and user operates via buttons and a simple system interface.
 - Features large conveying capacity to realize one-to-one feeding.
 - Equipped with high-pressure blower with small size, ease of installation and use.
 - Consisted of dust separator and dust collecting bin for easy cleaning and maintenance.
 - Indicator light shows the working status and warning.



欧规料斗
Eurocode hopper



技术参数 Sechnical parameter

型号 Model	马达 Motor		输送能力 Conveying capacity	储料桶容量 Material Hopper volume	送料管内径 Conveying tube inner dim	外形尺寸 External dimensions		重量 Weight	
	型式 Type	规格 Specification				主体 Main controller	储料桶 Hopper	主体 Main controller	储料桶 Hopper
TMVAL-1HP	感应式 Induction	1HP3Φ	300KG/H	7.5L	Φ38mm	450x400x900	400x280x440	38	6
TMVAL-2HP	感应式 Induction	2HP3Φ	450KG/H	7.5L	Φ38mm	450x400x950	400x380x500	40	12
TMVAL-3HP	感应式 Induction	3HP3Φ	550KG/H	12L	Φ38mm	500x450x1050	400x380x500	42	12
TMVAL-5HP	感应式 Induction	5HP3Φ	650KG/H	12L	Φ51mm	600x550x1150	520x550x800	48	24
TMVAL-7.5HP	感应式 Induction	7.5HP3Φ	800KG/H	24L	Φ51mm	800x700x1250	800x670x1000	60	36

Multi-hopper LOADER 一对多台吸料机

产品特点

Product Features

- 一机多斗微电脑控制型，标配机型最多可配6个料斗。
(标配为一个真空料斗,其余为电眼料斗)
 - 尤其适用干燥、供料一体化系统，简化系统结构，提高使用效率，方便操作。
 - 节省设备配置，节约空间。
 - 全自动微电脑操作控制程序，操作、安装、调试方便。
 - 维修保养方便、快捷。
 - 可选配PLC触摸屏控制，吸料斗可配多于6个料斗。
 - 可根据实际使用情况选配真空料斗和电眼料斗搭配数量。
- 1 host machine controlling up to 6 hoppers is the standard configuration.
(with one vacuum hopper, others as sensor switch hoppers)
 - Suitable for integrating into system with dryer and conveyor, which simplifies system and improves efficiency.
 - Saves cost and space.
 - Controlled by microcomputer, and the integrated control is for easy operation.
 - Easy maintenance.
 - Can be customized to control more than 6 hoppers with PLC touchscreen.
 - Depending on user's requirement, optional combination of multiple vacuum hoppers and photoelectric sensor hoppers can be customized.



磁簧料斗
Magnetic spring hopper

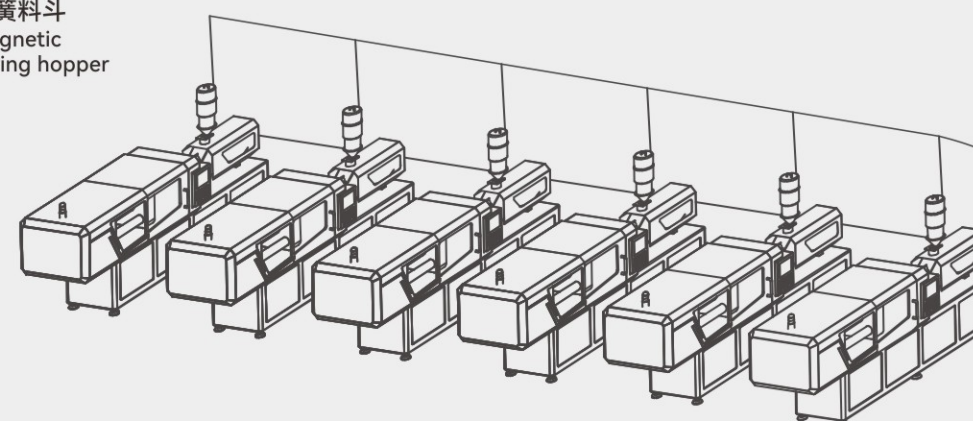

吸料机
Loader

Air-hotted DRYER 热风干燥机

产品特点

Product Features

- 加热桶采用不锈钢制作，保证原料不被污染并且清理更容易。
- 不锈钢网板散风装置，使热风更均匀地吹向原料，整个桶内温度均匀，原料不易结块。
- 加热桶与料斗较链联接结构，打开方便省力，换料与清理更容易。
- 开门式的磁力底座，取出磁力架清理铁屑等方便快捷。
- 可选配24H定时启动装置，减少上班时的预热时间，提高效率。
- 可选配热风回收装置，降低能耗。
- 可选配集尘器，保证粉尘不污染车间。
- The heating barrel is made from the stainless steel to ensure that the material is not polluted and easier to be cleaned.
- The air dispersion device of the stainless steel net plate enables the heat air to evenly blow the material. The temperature is even in the barrel to prevent material lumping.
- There is a hinge connection structure between the heating barrel and the hopper, which facilitates opening, reloading and cleaning.
- An open-door type magnetic base, which is convenient and easy to take out the magnet for cleaning the scrap iron.
- The 24hours Timer startup device of any time can be matched to reduce pre-heating time on duty and improve efficiency.
- The hot air recycler device can be matched to reduce energy consumption.
- The Hopper dust collector can be matched to prevent the dust into the workshop.



技术参数 Sechnical parameter

型号Model	料桶容量 Capacity (KG)	干燥电热 Heater Power (kW)	风机 Blower Power (W)	外型尺寸 External Dimensions (LxWxH)	底座尺寸 Seat Dimensions (LxWxH)	适用成型机 Adaptable injectioner	重量 Weight (KG)
TMZ-25	25	3.2	120	725 x 405 x 950	150x150x60	30-60	38
TMZ-50	50	4.2	180	840x490x1070	160x160x75	125-500	75
TMZ-75	75	5	180	900 x550 x1175	160x160x75	500-1000	85
TMZ-100	100	7	250	955x605x1410	200x200x90	1000-1500	95
TMZ-150	150	9	250	960x610x1560	200x200x90	1500-2000	120
TMZ-200	200	12	400	1230x770x1660	230x240x105	2000-2500	150
TMZ-250	250	14.5	400	1235x 775 x 1790	230x240x105	2500-3000	170
TMZ-300	300	14.5	400	1335x870x1810	230x230x110	3000-4000	200
TMZ-400	400	18	500	1360x915x1870	280x280x120	4000-6000	225
TMZ-600	600	24	800	1360x950x2080	280x280x135	6000-8000	250
TMZ-800	800	30	1100	1380x1150x2250	280x280x135	8000-10000	300
TMZ-1000	1000	37	3000	1400x1200x2600	280x280x135	8000-12000	360

Euro DESIGN DRYER 欧化干燥机

产品特点

Product Features

- 本机料斗采用优质不锈钢制作，可有效保证原料不受污染。
- 外层采用特殊材料，美观新颖。
- 内外层间有高效保温材料，减少热量损失。
- 采用热风下吹式设计，使料桶内温度更均匀。
- 控温采用进口温控表，PID控制，可精确控温度。
- 配备24小时定时器，可实现提前开机，提高工作效率。
- 配备清料门，可方便清理料桶。
- The hopper is made from high quality of stainless steel to ensure that the materials won't be polluted.
- The out layer is made of special material which is fashionable and attractive.
- The high-efficiency insulation material between internal layer and out layer to reduce the heat loss.
- Hot air down-blowing design ensures the even temperature in the hopper.
- The temperature is controlled by the import PID temp. controller to ensure the precision temperature.
- The 24H timer can achieve device startup in advance to improve work efficiency.
- Equipping with the cleaning door, which is convenient for cleaning the hopper



技术参数 Sechnical parameter

型号Model	料桶容量 Capacity (KG)	干燥电热 Heater Power (kW)	风机 Blower Power (W)	电压 Voltage (V)	外型尺寸 External Dimensions (LxWxH)	重量 Weight (KG)
TMZ-50-E	50	5.1	157	3Φ 380VAC 50Hz	720*820*1280	110
TMZ-75-E	75	5.4	246		730*820*1310	120
TMZ-100-E	100	10.8	246		900*1000*1660	140
TMZ-150-E	150	15	350		1000*1000*1780	170
TMZ-200-E	200	15	350		1030*1100*1910	195
TMZ-300-E	300	16	400		1200*1210*2150	250
TMZ-400-E	400	21	400		1365*1285*2195	310
TMZ-500-E	500	23	750		1430*1345*2330	335
TMZ-600-E	600	24	750	1480*1400*2550	400	

Large European DRYING MACHINE 大型欧化干燥机



产品特点

Product Features

- 1000~3000kg大型干燥机设有双层保温结构。
 - 特设下吹风管及环流排风功能，保证塑料干燥温度均匀提高干燥效率。
 - 与原料接触部分均采用不锈钢材料制作，保证原料精纯度。
 - 广开门设计，密封良好，清料方便。
 - 采用微电脑P.L.D.控制温度控制准确。
 - 设有双重过热保护装置，可减少因人或机械故障而产生的意外发生。
- Dryer with 1000-3000kg capacity consisted of 2 insulating layers for heat preservation.
 - Downward airflow and circumfluent hot air ensure even drying and high efficiency.
 - Material contact parts are made of stainless steel to assure purity of materials.
 - Big access door is for easy cleaning.
 - Adopted P.L.D. control for accurate temperature control.
 - Consisted of 2 high-temperature protective devices for safety.

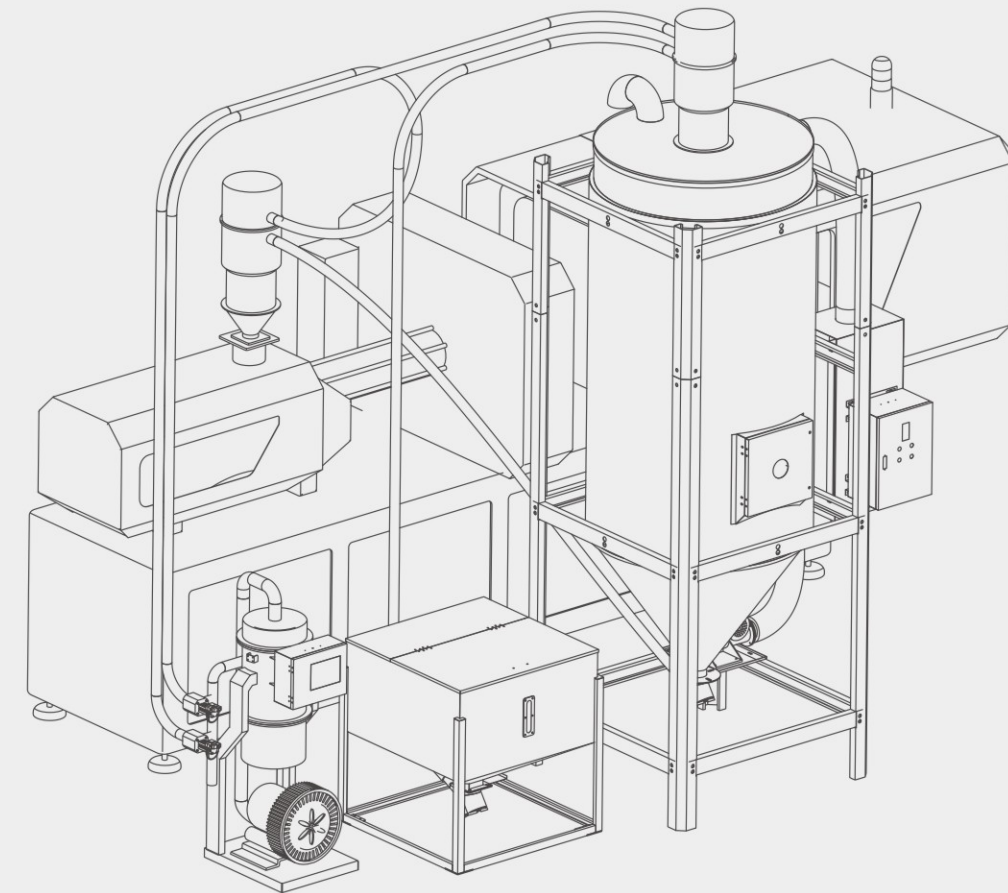

技术参数 Sechnical parameter

型号Model	料桶容量 Capacity (KG)	干燥电热 Heater Power (kW)	风机 Blower Power (W)	电压 Voltage (V)	外型尺寸 External Dimensions (LxWxH)	重量 Weight (KG)
TMZ-800-E	800	36	1100	3Φ 380VAC 50Hz	1650x1600x2950	570
TMZ-1000-E	1000	40	1100		1750x1250x3100	695
TMZ-1500-E	1500	51	1500		1750x1550x3600	850
TMZ-2000-E	2000	65	3000		1850x1650x3750	1130
TMZ-3000-E	3000	75	4000		2040x1850x4050	1480

PET CRYSTALLIZER

PET结晶干燥机

产品特点

Product Features

- 可靠、高品质的原料输出；完备的结构及控制设计，防止原料结块、变形。
 - 搅拌料斗防止结块；独特设计的搅拌叶和定位杆可保证原料经常翻滚来碾碎可能形成的任何团块和防止处理过程中的原料结块。
 - 自动连续操作；自动检测料斗内部温度，确保高品质结晶原料的输出。
 - 满足不同原料需要；可直接在线处理也可批量处理后储存结晶原料待日后使用。
 - 设计安全，方便清洁；进入门和可移动锥底灵活设计，让搅拌器可以从顶部或底部移开，清料方便。
- Reliable and high-quality raw material output; complete structure and control design to prevent raw material agling and deformation.
 - The mixing hopper prevents clumping; the uniquely designed mixing blades and positioning rods can ensure that the raw materials often roll over to crush any clumps that may be formed and prevent the raw material from clumping during the processing process.
 - Automatic continuous operation; automatic detection of the internal temperature of the hopper. Ensure the output of high-quality crystalline raw materials.
 - It can meet the needs of different raw materials; it can be processed directly online or batches to store crystalline raw materials for future use.
 - The design is safe and easy to clean; the entry door and moveable cone bottom are flexibly designed, so that the mixer can be removed from the top or bottom, and the cleaning is convenient.

工作原理

Working Principle

结晶系统可将非结晶PET原料颗粒转变成结晶状来进行干燥，在高温下干燥以得到低水分原料而不需担心结块。它由一个高温热源，一个带搅拌器的绝热料斗和一个旋转下料阀组成，并可轻易地与其他原料处理设备搭配使用。

The crystallisation system can convert non-crystalline PET raw material particles into crystals for drying, and dry them at high temperatures to obtain low-moisture raw materials without worrying about agglomeration. It consists of a high-temperature heat source, an adiabatic hopper with agitator and a rotary discharging valve, and can be easily used with other raw material processing equipment.



技术参数 Sechnical parameter

型号Model	装料量 Loading capacity (L)	搅拌电机功率 Stirring motor power (kW)	风机功率 Blower Power (W)	电热功率 Electric heating power (kW)	工作能力 Working ability (KG/hr)	外型尺寸 External Dimensions (LxWxH)	净重 Weight (KG)
TM-160-R	160	0.55	550	12	50	1430x1250x2800	230
TM-500-R	500	1.1	2200	24	150	1670x1450x3520	500
TM-600-R	600	1.5	2200	30	150	1480x1550x4000	540

2-in-1 Euro DESIGN DRYER

双机一体欧化干燥机



技术参数 Sechnical parameter

型号Model	料桶容量 Capacity (KG)	干燥电热 Heater Power (kW)	风机 Blower Power (W)	电压 Voltage (V)	外型尺寸 External Dimensions (LxWxH)	重量 Weight (KG)
TM-50-E	50	5.1	157	3Φ 380VAC 50Hz	850×905×1400	110
TM-75-E	75	5.4	246		850×905×1400	120
TM-100-E	100	10.8	246		900×1000×1660	140
TM-150-E	150	15	350		1000×1000×1780	170
TM-200-E	200	15	350		1030×1100×1910	195
TM-300-E	300	16	400		1200×1210×2150	250
TM-400-E	400	21	400		1365×1285×2195	310
TM-600-E	600	24	750		1480×1400×2550	400

Dehumidifier

DRYER

除湿机

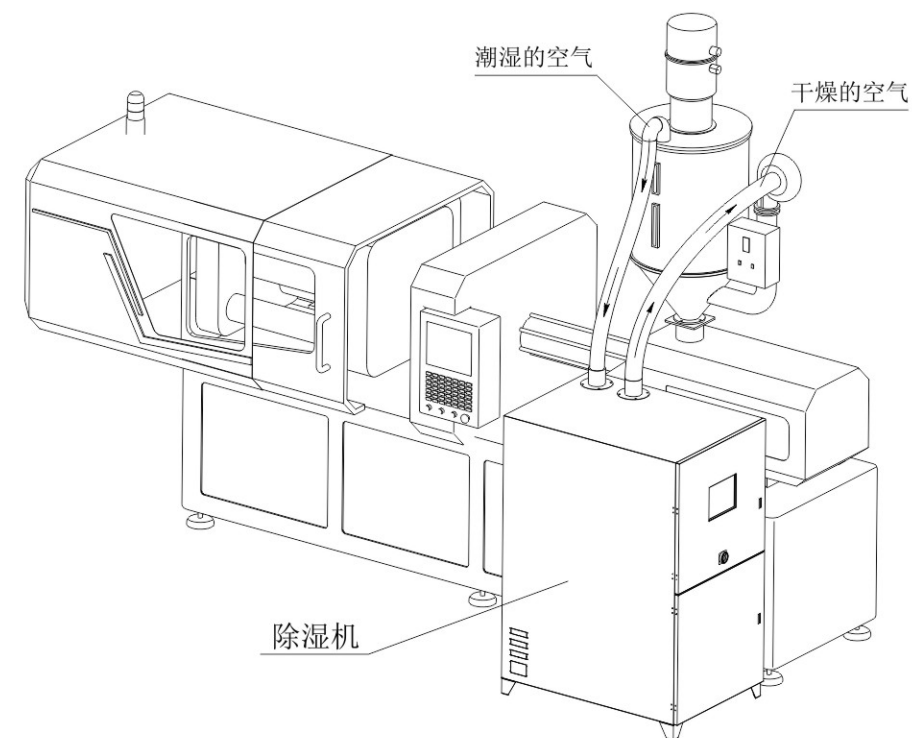

产品特点

Product Features

- 采用P.I.D温度控制系统，该系统具有再生温度设定与实际温度显示屏幕。
- 采用双冷凝器结构，确保更低的回风温度及露点。
- 蜂巢可达到-40°C以下露点，在配置增加状态下更可达到-50°C甚至更低的露点。
- 可选配PLC控制搭配LCD触控式人机界面。
- 可随时监控机器除湿效果的露点计供选配。
- 机器占地小，移动方便，可任意更换机台使用。
- P.I.D temperature controlling system adopted, with displays of regeneration temperature and real temperature.
- Double-condenser adopted, low temperature of recycling air and low dew-point assured.
- Dew-point up to -40°C, lower dew-point available with enhanced configuration.
- PLC control and LCD touch screen control available.
- Dew-point meter to supervise the dehumidifying effect (optional).
- Small footprint, easy to move.

技术参数 Sechnical parameter

型号Model	TMCD-50H	TMCD-80H	TMCD-120H	TMCD-150H	TMCD-200H
干燥系统 Drying system					
干燥电热功率 (kW) Drying heating power	3.9	6.2	6.2	9	12
干燥风机功率 (kW) Drying fan power	0.55	0.75	0.75	1.5	1.5
除湿系统 Dehumidification system					
再生电热功率 (kW) Regenerative heating power	3.9	3.9	3.9	6	6
再生风机功率 (kW) Regenerative fan power	0.2	0.25	0.25	0.55	0.55
除湿风量 (m/hr) Dehumidification air volume	550	80	120	150	200

型号Model	TMCD-300H	TMCD-400H	TMCD-700H	TMCD-1000H
干燥系统 Drying system				
干燥电热功率 (kW) Drying heating power	18	24	32	48
干燥风机功率 (kW) Drying fan power	3	4	5.5	12.5
除湿系统 Dehumidification system				
再生电热功率 (kW) Regenerative heating power	9	9	12	18
再生风机功率 (kW) Regenerative fan power	0.75	0.75	1.5	3
除湿风量 (m/hr) Dehumidification air volume	300	400	700	1000

3-in-1 DEHUMIDIFIER 三机一体除湿机

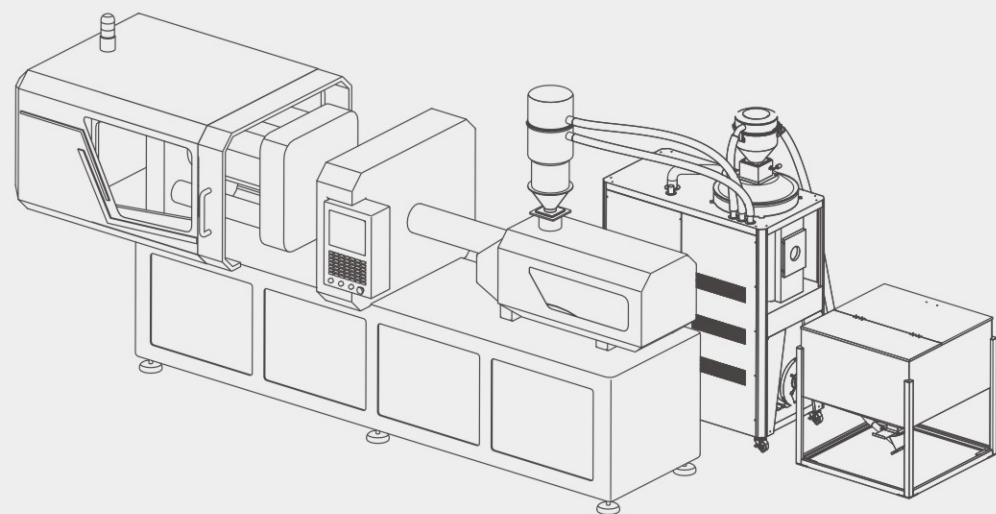

产品特点

Product Features

- 集干燥、除湿、两段送料三种功能于一体，也可根据客户需要做三段送料。
- 除湿干燥回路采用全密闭设计，确保更低露点的空气不与外界空气接触。
- 送料系统全密闭设计，保证了干燥后的原料不与外界空气接触而再次受潮。
- 送料装置加装料阀，保证送料管路中无残余的原料，送料更顺畅。
- 双层保温干燥桶，有效防止热量散失，节约加热能耗。
- 高效能的散热器，确保更低温、更低露点的空气。
- Combine the three functions of Drying, Dehumidifying and Conveying into one. Also can make the equipment convey the materials onto three hoppers according to customers requirements.
- The dehumidification system is designed to be closely hermetic, which ensures the air of low dew point doesn't contact with the outside air.
- The conveying system is designed to be closely hermetic, which ensures the dried material not contacting with the outside air and being wet again.
- The shut off valve is equipped on the conveying system to ensure no remnant materials in the material pipeline and smooth conveying.
- Double-layer heat preservation dry barrel to effective prevent the heat loss and save energy consumption.
- High efficient heat dissipater to ensure the air with lower temperature and lower dew point.

技术参数 Sechnical parameter

型号Model	TMCD-80U/50H	TMCD-120U/80H	TMCD-160U/80H	TMCD-160U/120H	TMCD-230U/120H	TMCD-230U/150H	TMCD-300U/150H	TMCD-300U/200H	TMCD-450U/200H
干燥系统 Drying system									
干燥电热功率 (kW) Drying heating power	3.9	6.2	6.2	6.2	6.2	9	9	12	12
干燥风机功率 (kW) Drying fan power	0.55	0.75	0.75	0.75	0.75	1.5	1.5	1.5	1.5
保温料桶容量 (L) Capacity of insulation barrel	80	120	160	160	230	230	300	300	450
除湿系统 Dehumidification system									
再生电热功率 (kW) Regenerative heating power	3.9	3.9	3.9	3.9	3.9	6	6	6	6
再生风机功率 (kW) Regenerative fan power	0.2	0.25	0.25	0.25	0.25	0.55	0.55	0.55	0.55
除湿风量 (m/hr) Dehumidification air volume	550	80	80	120	120	150	150	200	200
送料系统 Feeding system									
送料风机功率 (kW) Feeding fan power	1.1	1.1	1.1	1.1	1.5	1.5	1.5	1.5	1.5
吸料机配管 (inch) Suction machine piping	1.5	1.5	1.5	1.5	1.5	1.5	1.5	1.5	1.5
ZHR-U-E料斗 (L) ZHR-U-E hopper	7.5	7.5	7.5	7.5	7.5	7.5	7.5	7.5	7.5
ZHR-U料斗 (L) ZHR-U hopper	7.5	7.5	7.5	7.5	7.5	7.5	7.5	7.5	7.5

型号Model	TMCD-450U/300H	TMCD-600U/300H	TMCD-600U/400H	TMCD-750U/400H	TMCD-900U/700H	TMCD-1200U/700H	TMCD-1600U/1000H
干燥系统 Drying system							
干燥电热功率 (kW) Drying heating power	18	18	24	24	32	32	48
干燥风机功率 (kW) Drying fan power	3	3	4	4	5.5	5.5	12.5
保温料桶容量 (L) Capacity of insulation barrel	450	600	600	750	900	1200	1600
除湿系统 Dehumidification system							
再生电热功率 (kW) Regenerative heating power	9	9	9	9	12	12	18
再生风机功率 (kW) Regenerative fan power	0.75	0.75	0.75	0.75	1.5	1.5	3
除湿风量 (m/hr) Dehumidification air volume	300	300	400	400	700	700	1000
送料系统 Feeding system							
送料风机功率 (kW) Feeding fan power	2.2	2.2	2.2	2.2	2.2	2.2	3
吸料机配管 (inch) Suction machine piping	1.5	1.5	1.5	1.5	2	2	2
ZHR-U-E料斗 (L) ZHR-U-E hopper	15	15	15	15	24	24	24
ZHR-U料斗 (L) ZHR-U hopper	15	15	15	15	24	24	24

Water-cooled CHILLER 水式冷水机



高品质压缩机

作为冷水机的核心，台玛冷水机挑选欧美日全新进口优质原装压缩机，内置安全保护，低噪音，省电耐用。

水箱式蒸发器

不锈钢厚质水箱式蒸发器，内置自动补水等装置，省去工程安装中的膨胀水箱，方便安装保养。并适用于大温差小流量等特殊场合。

水冷式冷凝器

日本神户最新高效外螺纹铜管制作，散热量大，体积小。运用最新CAD、CAM设计加工技术，配合CNC加工中心制作完成，结构紧凑、可靠性高、外形美观、高效节能。

High quality compressor

As a heart of water-cooling machine, Taima choose the original compressor from European and USA with safety production inside, low noise, energy saving and long life.

Evaporator as water tank style

Thick Stainless steel Evaporator with automatic water supplying device, the swell water tank during the installation will be saved, easy to install and maintain and also suitable for the case of big temperature deviations, small flow.

Water-cooling condenser

Made from UKB latest outside threaded copper tube, good heat dissipation and small occupation. Use the latest CAD, CAM R&D technic, made from CNC which has a feature of compact structure, energy saving, good shape and reliable performance.

机组配置

配置精密电子温度控制器。精确控制水温于7-35C以内。内置压缩机超负载保护器，循环水泵超负载掣，系统高低压力异常保护器，高效进口干燥过滤器及膨胀阀，维修手阀接口等装置，确保了机器可靠安全运行，方便了保养维修。

选购配置

- 可选购不同压力规格水泵满足不同送水压力要求。
- 可选购不同电压频率的电源要求。

多功能操作面板

操作面板上装有控制系统保险，压缩机开关按钮，水泵开关按钮，电子温控器，各项安全保护故障灯，机组启动运转指示灯，操作简单、使用方便。

Machine configuration

Equipped with exact electric temperature controller which control the water temperature between 5-20°C inside which there is a overload protector, high pressure abnormal protector, imported dry filter and swell valve for stable running and easy repairing and maintainance.

Optional scheme

- Choose different specifications to meet different water pump pressure.
- Choose different electric voltage frequency requirements for power supply.

Pump configuration for option

Imported high efficiency pump is available according to customer's requirement

Multi function operation panel

There are current monitor compressor on-off switch, pump on-off switch, electric temperature controller, safety running alert light on the panel

型号 Model	UNIT	TM-05IW	TM-10IW	TM-12IW	TM-15IW	TM-20IW	TM-25IW	TM-30IW	TM-40IW	
制冷量 Refrigeration capacity	kw	15	30.5	34.3	45	61	69	92	122	
	kcal/h	12900	26230	29498	38700	52460	59340	79120	104920	
压缩机 Compressor	输入功率 Input power	kw	3.75	3.75x2	9	11	15	18	22	30
	额定功率 Rated power	hp	5	5x2	12	15	10x2	12x2	10x3	20x2
蒸发器 Evaporator	类型 Type	盘管式蒸发器 pipe-coil evaporator				壳管式蒸发器 Shell evaporator				
	水管口径 Pipe diameter	Inch	1	1.5	2	2	2-1/2	2-1/2	2-1/2	3
冷冻媒体 Refrigerant	类型 Type	R22								
	填充量 Quantity	KG	2.5	5	6	7.5	10	11	12	18
水冷冷凝器 Water cooled condenser	类型 Type	壳管式蒸发器 Shell evaporator								
	水管口径 Pipe diameter	Inch	1	1-1/2	2	2	2-2/2	2-1/2	2-1/2	3
冷却水量 Chl water flow rate	L/min	70	110	150	170	230	270	330	480	
水箱容量 Water tank capacity	liter	50	70	125	125	140	140	150	180	
水泵 Pump	功率 Power	kW	0.55	1.1	1.5	1.5	2.2	2.2	4	4
	流量 Flow rate	L/min	0.75	1.5	2	2	3	3	5	5
管径 Pipe connection size	冷水出口 Cooling water outlet	Inch	100	100	200	200	300	300	300	300
	冷水回口 Cooling water inlet	Inch	3/8x4	1.5	2	2	2-1/2	2-1/2	2-1/2	3
外形尺寸 Dimension (LxWxH)	水冷 Water cooled	cm	114x61x101	136x71x128	136x71x128	154x85x130	210x85x151	210x85x151	224x88x151	250x85x150

Air-cooled CHILLER 风式冷水机



高品质压缩机

作为冷水机的核心，台玛冷水机挑选欧美日全新进口优质原装压缩机，内置安全保护，低噪音，省电耐用。

水箱式蒸发器

不锈钢厚质水箱式蒸发器，内置自动补水等装置，省去工程安装中的膨胀水箱，方便安装保养。并适用于大温差小流量等特殊场合。

风冷式冷凝器

高速冲床，翻片质量可靠。二次翻边，铜管和翅片更加紧密接触，换热效率高。采用全进口铜管和全自动弯头焊接，大大增强了气密性，杜绝制冷剂泄露现象。尤其适合水资源缺乏和水质硬度高的地区使用。

High quality compressor

As a heart of water-cooling machine, Taima choose the original compressor from European and USA with safety production inside, low noise, energy saving and long life.

Evaporator as water tank style

Thick Stainless steel Evaporator with automatic water supplying device, the swell water tank during the installation will be saved, easy to install and maintain and also suitable for the case of big temperature deviations, small flow.

Air-cooled condenser

High-speed punch, turning with good quality. Two flange, in order to keep close contact between copper tube and fin, high heat exchange efficiency. Imported copper tube and automatic welding elbow, greatly increases the air tightness, prevent Refrigerant leakage. Especially suitable for use in lack of water and high hardness water area.

机组配置

配置精密电子温度控制器。精确控制水温于7-35℃以内。内置压缩机超负载保护器，循环水泵超负载掣，系统高低压力异常保护器，高效进口干燥过滤器及膨胀阀，维修手阀接口等装置，确保了机器可靠安全运行，方便了保养维修。

选购配置

- 可选购不同压力规格水泵满足不同送水压力要求。
- 可选购不同电压频率的电源要求。

多功能操作面板

操作面板上装有控制系统保险，压缩机开关按钮，水泵开关按钮，电子温控器，各项安全保护故障灯，机组启动运转指示灯，操作简单、使用方便。

Machine configuration

Equipped with exact electric temperature controller which control the water temperature between 5-20℃ inside which there is a overload protector, high pressure abnormal protector, imported dry filter and swell valve for stable running and easy repairing and maintainance.

Optional scheme

- Choose different specifications to meet different water pump pressure.
- Choose different electric voltage frequency requirements for power supply.

Pump configuration for option

Imported high efficiency pump is available according to customer's requirement

Multi function operation panel

There are current monitor compressor on-off switch, pump on-off switch, electric temperature controller, safety running alert light on the panel

型号 Model	UNIT	TM-05IA	TM-10IA	TM-12IA	TM-15IA	TM-20IA	TM-25IA	TM-30IA	TM-40IA	
制冷量 Refrigeration capacity	kw	15	30.5	34.3	45	61	69	92	122	
	kcal/h	12900	26230	29498	38700	52460	59340	79120	104920	
压缩机 Compressor	输入功率 Input power	kw	3.75	3.75x2	9	11	15	18	22	30
	额定功率 Rated power	hp	5	5x2	12	15	10x2	12x2	10x3	20x2
蒸发器 Evaporator	类型 Type	盘管式蒸发器 pipe-coil evaporator				壳管式蒸发器 Shell evaporator				
	水管口径 Pipe diameter	Inch	1	1.5	2	2	2-1/2	2-1/2	2-1/2	3
冷冻媒体 Refrigerant	类型 Type	R22								
	填充量 Quantity	KG	2.5	5	6	7.5	10	11	12	18
风冷冷凝器 Air cooled condenser	类型 Type	壳管式蒸发器 Shell evaporator								
	水管口径 Pipe diameter	Inch	0.19x2	0.25x2	0.5x2	0.55x2	0.5x4	0.5x4	0.4x6	0.4x8
冷却水量 Chilled water flow rate	L/min	70	110	150	170	230	270	330	480	
水箱容量 Water tank capacity	liter	50	70	125	125	140	140	150	180	
	kW	0.55	1.1	1.5	1.5	2.2	2.2	4	4	
水泵 Pump	功率 Power	0.75	1.5	2	2	3	3	5	5	
	流量 Flow rate	L/min	100	100	200	200	300	300	300	300
管径 Pipe connection size	冷水出口 Cooling water outlet	Inch	3/8x4	1.5	2	2	2-1/2	2-1/2	2-1/2	3
	冷水回口 Cooling water inlet	Inch	3/8x4	1.5	2	2	2-1/2	2-1/2	2-1/2	3
外形尺寸 Dimension (LxWxH)	风冷 Air cooled	cm	135x61x112	150x80x146	150x80x146	170x95x175	200x105x195	220x135x155	220x135x155	320x148x210

Screw CHILLER

螺杆式冷水机

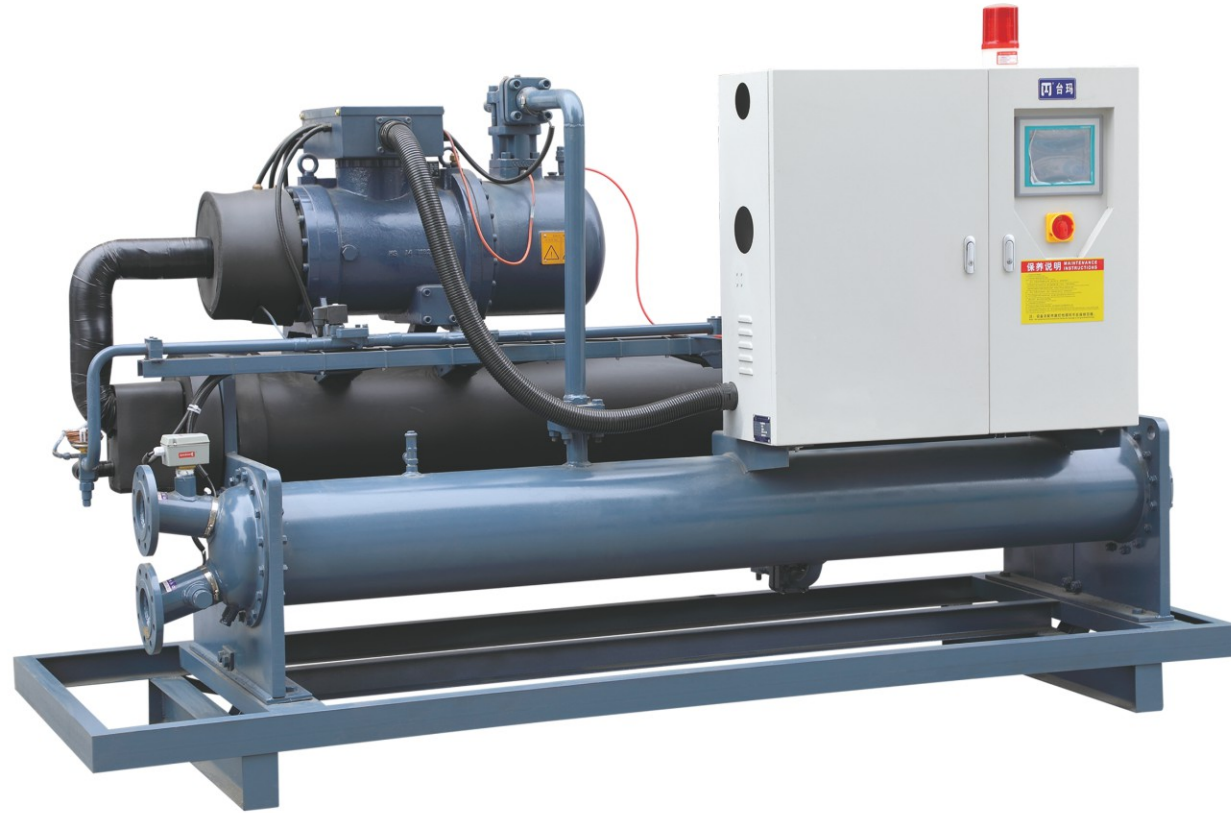

产品特点

Product Features

- 螺杆式压缩机，寿命长、噪音低。
- 机组自带能量调节，节省电能。
- 彩色触摸屏，操作简单、方便。高效外螺纹铜管增大换热面积，提高制冷量。
- Screw compressor, long life, low noise.
- The sets are equipped with energy adjusting which can save power.
- Colorful touch screen provides easy operation.
- Efficiency outside threaded copper tube, increase heat exc-hange area, improve cooling ability

集中供水示意图

Centralized water supply diagram

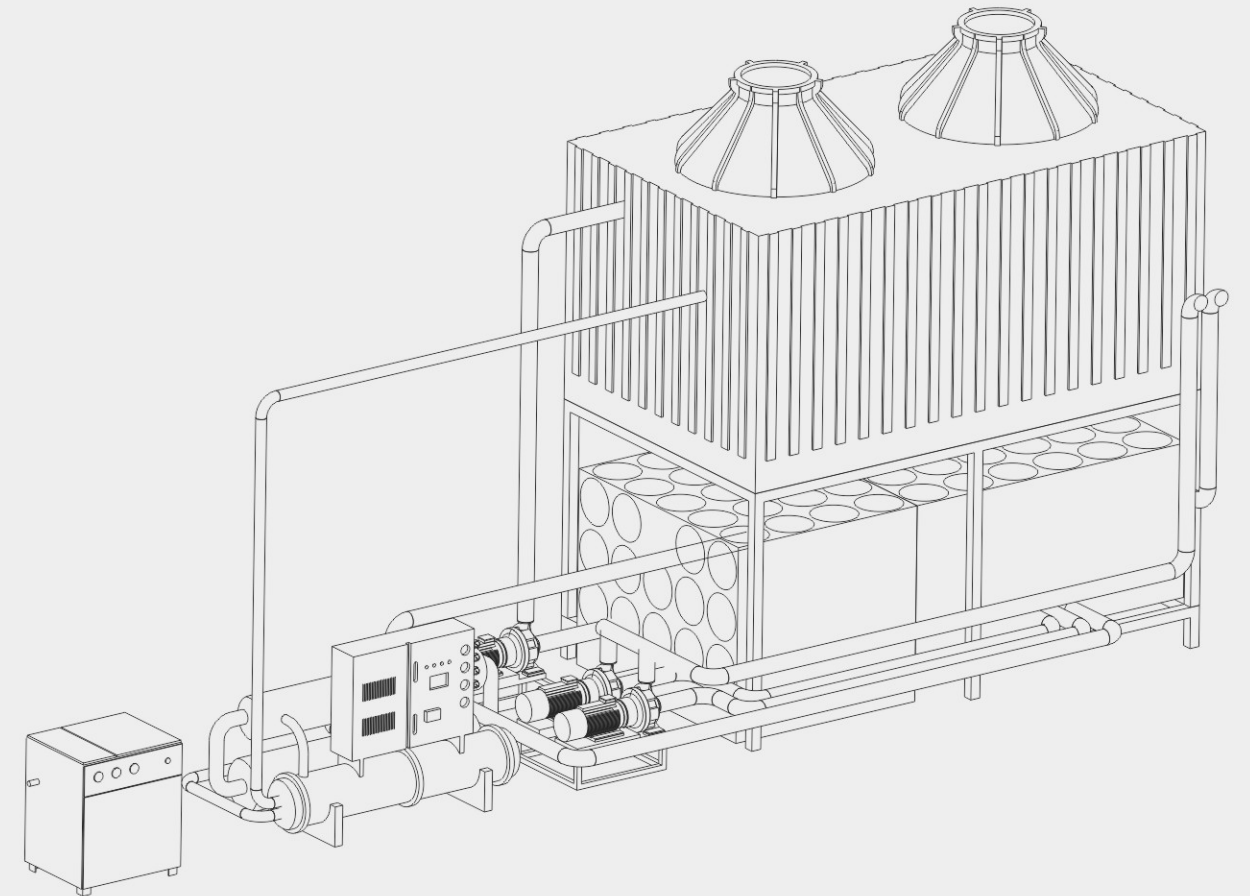

型号 Model	UNIT	TM-40WS	TM-50WS	TM-60WS	TM-80WS	TM-100WS	TM-120WS	TM-140WS	TM-160WS	TM-180WS	TM-200WS	TM-220WS	
制冷量 Refrigeration capacity	kcal/h	103200	129000	163400	236500	283800	339700	37800	421400	464400	494500	584800	
	kw	120	150	190	275	330	395	440	490	540	575	680	
输入功率 Input power	kw	27.6	34.8	43.6	60.9	72.6	85.4	94.8	105.0	116.5	124.7	155.2	
最大运行电流 Maximum Running Current	A	62.9	79.3	100.0	139.0	167.0	196.0	216.1	244.0	265.0	287.0	357	
能量调节范围 Capacity Control		100-75-50-25-0											
电源 Power supply		3Φ380V Hz											
制冷剂 Refrigerant	名称 Type	R22											
	充注量 Change	kg	20	25	30	40	45	54	72	78	88	95	103
压缩机 Compressor	控制方式 Control	感温式外部均匀膨胀阀 Temperature expansion valve											
	类型 Type	半封闭螺杆式 Screw Semi-hermetic											
蒸发器 Chiller	功率 Power	kw	30	37.5	45	60	75	90	105	120	135	150	165
	类型 Type	壳管式 Shell and Tube											
	流水流量 Flow Rate	m³/h	21	26	33	47.3	56.8	68	76	84.3	93	99	117
冷凝器 Condenset	水阻力 Pessure Drop		22	38	39	42	42	45	40	40	44	44	44
	进出水管径 Pipe size	DN	65.0	65.0	80.0	100.0	100.0	100.0	125.0	125.0	125.0	125.0	150
保护装置 Safety Device	冷却水流量 Flow Rate	壳管式 Shell and Tube											
	流水流量 Flow Rate	m³/h	27	33.5	42.5	61.5	74	88.3	98	110	121	129	152
	水阻力 Pessure Drop	KPa	38	43	43	45	45	48	45	45	49	49	49
机组重量 Net Weight	进出水管径 Pipe size	DN	65.0	65.0	80.0	100.0	100.0	100.0	125.0	125.0	125.0	125.0	150
			高低压开关 防冻开关 可熔栓 过载保护装置 线圈过热保护器 温度自动开关 逆相保护器。 High/Low Pressure Switch Ant-frost Protector, Solube Chock, Overload Protector Coil Overheat Protector Automatic Tmperature Sensitive Switch Anti-phase Protector										
运行重量 Operating Weight	kg	880	980	1140	1800	1900	2000	2290	2490	2750	2950	3200	
	kg	1000	1110	1250	1960	2050	2180	2500	2650	3000	3150	3500	

Mold HEATER 模温机



高温模温机



油水模温机

产品特点

Product Features

- 采用微电脑控制、液晶显示、按钮操作。
- 采用P.I.D.参数自整定双向(加热/冷却)控制，分段式控温系统，在任何状态下均可保持稳定的模具温度，控温精度高达±0.5°C。
- 可进行中、英文切换，操作界面简洁易懂，故障问题文字显示一目了然。
- 电器与加热装置分离式设计，有效避免了高温对电器造成的损坏。
- 采用优质、高效泵浦，能适应各种模具的控温要求。
- 内部采用不锈钢制造，耐腐蚀、高压防爆、恒温时间长，热效率高。
- 六大保护功能：热电偶断偶报警、电源缺相保护、逆相保护、过载保护、过热保护及缺水保护。

- Microcomputer control, LCD display, button operation.
- P.I.D. parameter self-tuning two-way (heating/cooling) control, segmented temperature control system, in any state can maintain a stable mold temperature, temperature control accuracy up to 0.5°C.
- Chinese and English can be switched, the operation interface is simple and easy to understand, fault text display at a glance.
- Electrical appliances and heating device separate design, effectively avoid high temperature caused by electrical damage.
- Using high quality, high efficiency pump, can adapt to various mold temperature control requirements.
- The interior is made of stainless steel, corrosion resistance, high pressure explosion proof, constant temperature for a long time, high thermal efficiency.
- Six protection functions: thermocouple break alarm, power phase loss protection, reverse phase protection, overload protection, overheating protection and water shortage protection.

技术参数 Sechnical parameter

型号Model	传热媒体 Heat transfer medium	最高温度 Maximum temperature	泵功率 Pump power (kW)	泵流量 Pump flow (L/min)	泵扬程 Pump head (m)	容量 Capacity (L)	发热功率 Heating power (kW)	热媒出入口径 Heat media access caliber (inch)	外型尺寸 External Dimensions (cm)	净重 Weight (KG)
TMTW-06W	清水	95°C	0.37	35	30	/	6	12mmx3	88x31x74	60
TMTW-09W	清水	95°C	0.75	50	30	/	9	12mmx3	88x31x74	60
TMTW-12W	清水	95°C	1.5	80	45	/	12	12mmx4	88x31x74	60
TMTW-24W	清水	95°C	2.2	200	30	/	24	12mmx4	110x44x109	120
TMTW-36W	清水	95°C	3.75	380	35	/	36	1.5"	110x44x109	130
TMTW-60W	清水	95°C	3.75	380	35	/	60	1.5"	110x44x109	135
TMTW-06W-D	清水	95°C	0.37x2	35x2	30	/	6x2	12mmx6	88x62x74	98
TMTO-06W-D	传热油	200°C	0.37x2	35x2	30	10x2	6x2	12mmx6	88x62x74	102
TMTO-06W-R	传热油	200°C	0.55	33	40	18	6	3/8"x3	105x35x84	80
TMTO-09W-R	传热油	200°C	0.75	45	40	18	9	3/8"x3	105x35x84	85
TMTO-12W-R	传热油	200°C	0.75	45	40	18	12	3/8"x4	105x35x84	85
TMTO-06W	传热油	200°C	0.37	35	30	10	6	3/8"x3	88x31x74	62
TMTO-09W	传热油	200°C	0.75	50	30	10	9	3/8"x3	88x31x74	65
TMTO-12W	传热油	200°C	1.5	80	45	10	12	3/8"x4	88x31x74	75
TMTO-24W	传热油	200°C	2.2	320	30	10	24	3/8"x4	110x44x109	120
TMTO-36W	传热油	200°C	3.75	550	35	10	36	1.5"	110x44x109	130
TMTO-60W	传热油	200°C	3.75	550	35	10	54	1.5"	110x44x109	135

技术参数 Sechnical parameter

型号Model	最高温度 Maximum temperature	电热 Electric heating (kW)	泵功率 Pump power (kW)	泵流量 Pump flow (L/min)	泵扬程 Pump head (m)	接管直径 Nozzle diameter (inch)	外型尺寸 External Dimensions (cm)
TMTM-09WH	160°C	9	0.75	45	60	3/8"x3	88x31x74
TMTM-12WH	160°C	12	1.5	90	55	3/8"x4	88x31x74
TMTM-18WH	160°C	18	2.2	150	35	3/8"x6	110x44x109

注: 为确保加热温度的稳定性, 冷却水压需介于2~5kg/cm²; 电源: 3Φ380VAC 50Hz。
Note: In order to ensure the stability of heating temperature, the cooling water pressure should be between 2~5kg/cm²; Power supply: 3Φ380VAC 50Hz.

Heavy duty GRANULATOR

强力粉碎机



产品特点

Product Features

- 重负荷轴承、惯性设计合理、粉碎力强。
- 双层隔音料斗，降低噪音。
- 优质高速钢刀具，刀刃锋利、持久耐用。
- 易拆式设计，清理容易、维护方便。
- 电源连锁保护装置，确保操作安全。
- 有设计合理的静音型，供选择。

- Heavy-duty bearings, large inertial wheel and strong crushing ability.
- Easy-disassembly design, simple and easy to clean and maintain.
- Two-layer sound-insulated hopper to insulate noise.
- High-speed quality cutter, sharp edge, durable in operation.
- Interlock power protection to ensure operational safety.
- Good design soundproof for option

技术参数 Sechnical parameter

型号Model	功率 Power (kW)	转子直径 Diameter of rotor	碎料室 Granulation size (mm)	动刀片 Rotating blades	定刀片 Fixed blades	碎料量 Cutting ability (kg/h)	管网孔径 Screen sizw (mm)	机械尺寸 Mechanical size (LxBxWmm)	重量 Weight (kg)
TMG-180	1.1-1.5	Φ150	180x200	3x3	2	50-80	Φ6	620x560x850	130
TMG-230	2.2-3	Φ215	230x215	3x3	2	130-200	Φ8	1000x700x1050	250
TMG-300	5.5	Φ235	315x270	3x3	2	150-200	Φ10	1200x810x1200	400
TMG-400	7.5	Φ265	415x275	3x4	2	200-250	Φ10	1400x890x1400	500
TMG-500	11	Φ390	515x325	3x4	2	300-350	Φ10	1200x1050x1650	900
TMG-600	15	Φ310	610x320	3x6	2	350-450	Φ10	1550x1450x1800	1100
TMG-800	22-30	Φ400	830x480	3x8	4	450-600	Φ12	2100x1450x1800	2000
TMG-1000	45-45	Φ500	1010x660	3x10	4	700-1000	Φ12	2650x1680x2700	4800

Soundproof GRANULATOR

静音粉碎机

WWW.ZJTMKJ.CN

29-30



产品特点

Product Features

碎机可将大快料物体整块放入粉碎机，不需要切割，节省时间，提高操作的安全性。可粉碎保险杠周转箱、垃圾桶和大型吸塑等大型塑料产品。刀轴采用整体切割成形，旋转刀安装方式为八型块强压式，刀轴采用具有极强的抗震性能，刀具坚实耐用，根据使用情况不同可方便进行旋转刀具的伸缩调整。

Crusher can put big fast material object blocks in a mill don't need to cut, save time, improve the safety of the operation. Can be powder bumper, turnover box, dustbin and large blister and other large-scale plastic products. Using integral forming, cutting knife shaft rotation blade installation for eight piece of crush type, knife shaft is adopted with strong seismic performance, cutting tools are solid and durable, rotate tool according to different usage can be conveniently adjustable adjust.

技术参数 Sechnical parameter

型号 Model	功率 Power (kW)	转子直径 Diameter of rotor (mm)	碎料室 Granulation Size (mm)	动刀片 Rotating blades	定刀片 Fixed blades	碎料量 Cutting ability (kg/h)	管网孔径 Screen size (mm)	机械尺寸 Mechanical Size L×B×W (mm)	重量 Weight (KG)
TMGJ-800	22-30	Φ400	830×480	3×8	4	450-600	Φ12	2100×1450×1800	2000
TMGJ-1000	45-50	Φ500	1010×660	3×10	4	700-1000	Φ12	2650×1680×2700	4800

Immediately RECYCLING CRUSHER 机边粉碎机

中速机边粉碎机

Medium speed machine edge crusher

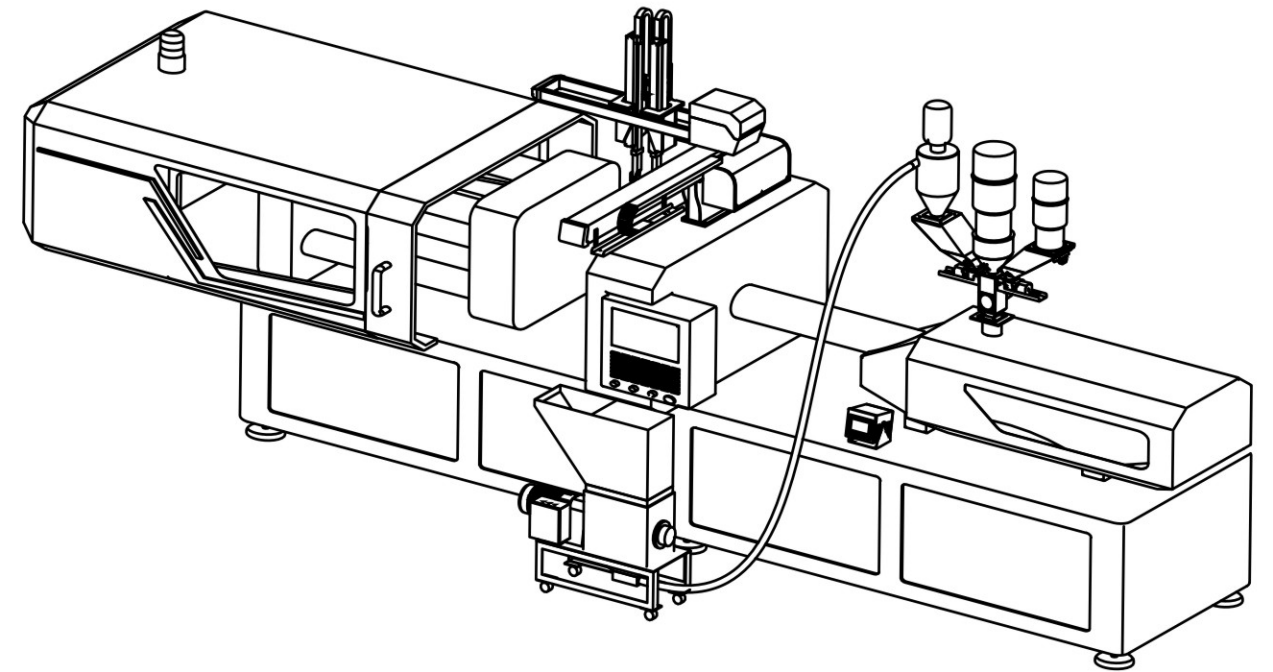
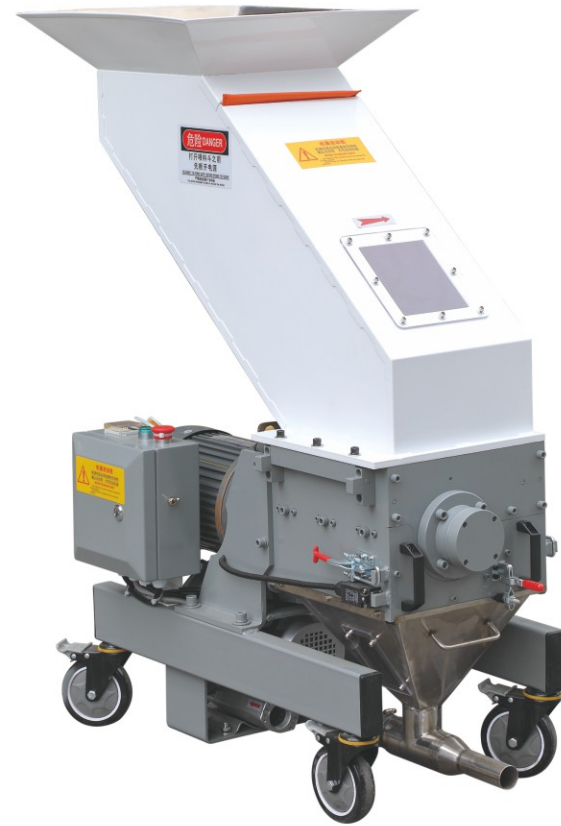
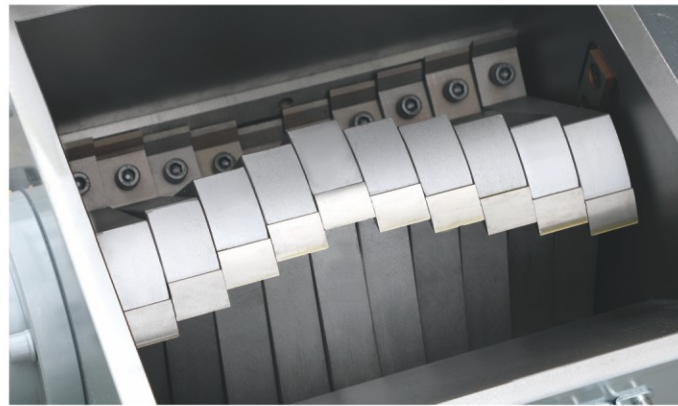

产品特点 Product Features

中速机边粉碎机

本中速粉碎机适用于塑胶成型机旁配合机械手或皮带输送机将机边水口料或少量不良品粉碎及回收。其具备转速低，传动扭矩大，噪音低，产生粉尘少，操作简便等优点。

Medium speed machine edge crusher

The device is applicable to the Injection molding machine besides, matching with the Extruding machine or the Belt conveyor to crush the runners or a small quantity of defective products. With feature of low rotational speed, low noise, less dust and convenient operation.

慢速机边粉碎机

本慢速粉碎机适用于坚厚及韧性较强的水口料与少量废料粉碎及回收。采用齿啮式刀具搭配切断刀之设计原理，可以达到无粉尘的粉碎效果。该机还配备有多重保护装置,操作安全

Slow speed machine edge crusher

The device is applicable to crushing hard and thick materials and a small quantity of waste Principle design of teeth cutters and staggered blades makes least dusts produced in the grinding process. The multiple security protection devices ensure high safety grade.

注: 2A配备风机送料
2C配备两料比例阀

Note: 2A series equipped with blower feeding device
2C series equipped with proportional valve

技术参数 Sechnical parameter

型号Model	粉碎室口径 Chamber caliber (mm)	破碎能力 Crushing capacity (kg/h)	转刀/定刀 Rotating / Fixed blade (pcs)	转速 Rotating speed	电机功率 Motor Power (kW)	风机功率 Blower Power	外型尺寸 External Dimensions (mm)	重量 Weight (kg)
慢速机边粉碎机 Slow speed machine edge crusher								
TM-1.5HP	240x160	15-30	/	28	1.5	0.55	1020x400x1400	110
TM-2HP	240x160	15-30	/	28	1.5	/	1020x400x1400	110
TM-3HP	240x250	30-50	/	28	1.5	0.55	1020x400x1400	120

慢速机边粉碎机

Slow speed machine edge crusher



Volumetric MIXER 计量式色母混合器

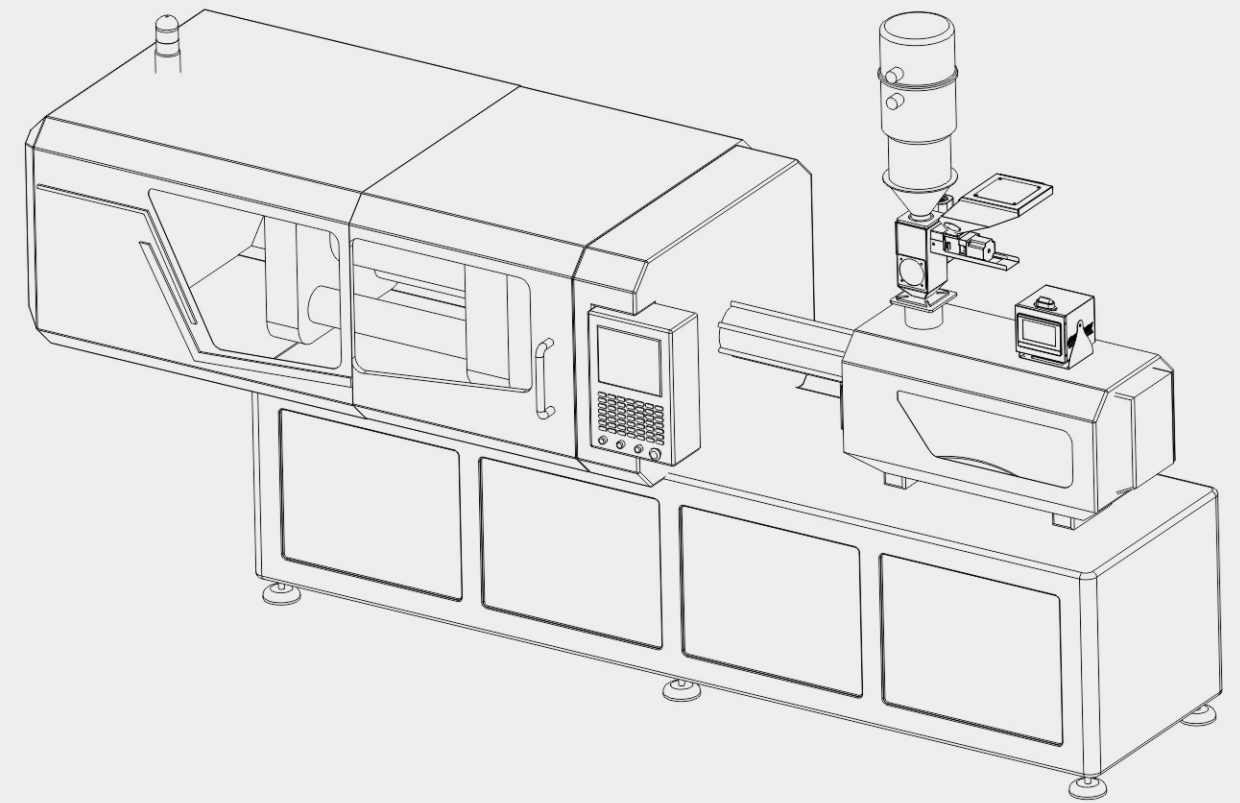

产品特点

Product Features

- 采用微PLC控制、液晶显示、按钮操作。
- 操作简单容易，故障问题文字显示一目了然。
- 采用原装进口直流无刷式减速马达，无需保养。
- 输送控制更精确，输送控制精度可达1~5%。
- 具有50组数据的永久记忆储存功能。
- 具有缺料(选配)、输送螺杆堵塞马达过载自动停机并报警功能。
- 模块式装配结构，拆装、维修保养方便，易于清理互换。
- 螺杆采用镀铬处理，经久耐用。
- 可满足2种外部信号输入控制要求(挤出机与射出机信号)，只需调换控制箱内接线插头位置。
- 2种不同的螺杆输出时间控制。
- 有强制清料功能，方便清理机内残余色母和更换色母。
- 全系列机型可配搅拌装置(选配)，使得原料与色母混合更均匀，产品颜色更准确。

- Controlled by microcontroller, and consists of LCD screen and keyboard.
- Simple operating system interface with troubleshooting function.
- Equipped with imported brushless gear motor that is free from maintenance.
- Conveying accuracy is between 1% and 5%.
- Store up to 50 program recipes.
- Automatically stops and alarms for material shortage(optional), jammed conveyor, and overloaded motor.
- Modularized structure for easy installation, maintenance and replacement.
- Chrome plated screw is reliable.
- 2 ports for external inputs (i.e. injection molding machine and extruder machine).
- There are 2 sizes of screw available for different output requirement.
- Cleaning function can discharge residual materials.
- All series can be optionally equipped with blender for better mixing materials.

技术参数 Technical parameter

型号Model	TMQ60-12	TMQ36-14	TMQ36-16	TMQ60-12DM	TMQ36-14DM	TMQ36-16DM
输出量 (kg/hr) Out put	0.3~3	0.5~5	0.8~10	(0.3~3)x2	(0.5~5)x2	(0.8~10)x2
马达功率 (W) Motor power	50	50	50	160(50x2+60)	160(50x2+60)	160(50x2+60)
马达转速 (rpm) Motor rotary speed	0~3000	0~3000	0~3000	0~3000	0~3000	0~3000
储料桶 (L) Materials barrel	10	10	10	10x2	10x2	10x2
减速比 Reduction ratio	30:1	30:1	30:1	30:1/30:1	30:1/30:1	30:1/30:1
螺杆外径 (mm) Screw diameter	12	14	16	2-12	2-14	2-16
外型 External	H (mm)	771	771	1377	1377	1377
	W (mm)	325	325	325	325	325
	D(mm)	667	667	667	667	667
重量 (kg) Net weight	16	16	16	30	30	30

注: 以上机型输出量测试是假定以比重1.2kg/L,直径为2~3mm的色母粒为标准测得数据。
Note: The data above is obtained from masterbatch with density 1.2ka/L and diameter 2-3mm.

Volumetric MIXER

容积式比例混合器



产品特点 Product Features

- 采用PLC控制，配置触摸式操作屏，操作简单。
- 采用螺杆计量方式，配比稳定，混合精度精确。
- 适合回收料、色母、原料等的比例混合。
- 配方存储功能缩短换料工序接时间。
- 全不锈钢材质，对原料无污染。
- 自动计量搅拌混合，是一台成型工厂无人化操作不可欠缺的装置。

- PLC control, touch screen, simple operation.
- Adopting screw metering method, the ratio is stable and the mixing precision is accurate.
- Suitable for recycling materials, masterbatch, raw materials, etc.
- Formula storage function shortens the connection time of refueling process.
- All stainless steel material, no pollution to raw materials.
- Automatic measuring and mixing is an indispensable equipment for unmanned operation in a molding factory.

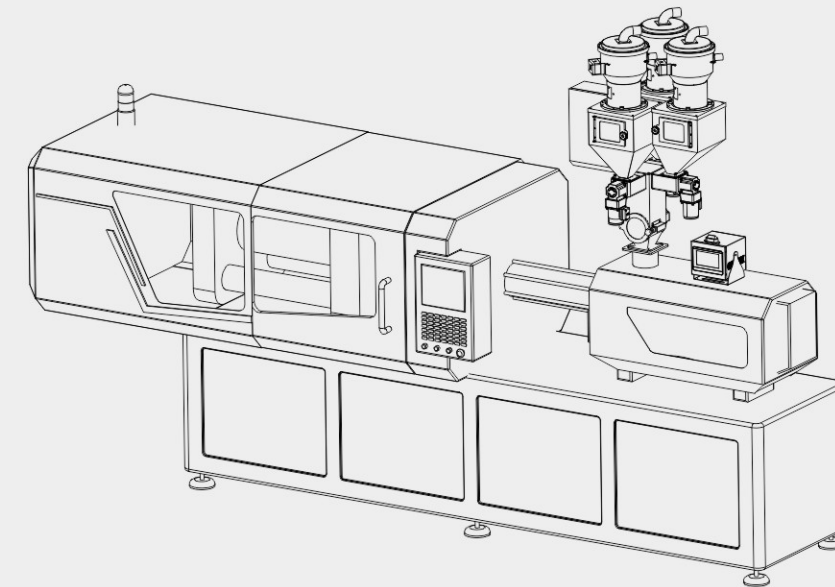

技术参数 Sechnical parameter

型号Model	TMV-40	TMV-60
电源 Power	220V 50/60Hz 1P	220V 50/60Hz 1P
单螺杆处理能力 Single screw handling capacity	0~150kg/h	0~1400kg/h
螺杆马达功率 Power of screw motor	60Wx3	90Wx3
搅拌马达功率 Stiring motor power	120W	120W
料斗容积 Bucket capacity	18L	18L
螺杆外径 The screw diameter	40mm	60mm
外形尺寸 Dimensions	950x850x950mm	950x850x950mm
产品重量 Product weight	90kg	95kg

本记录数值是在堆积密度为0.65g/cm³的原料，堆积密度为0.29g/cm³的粉碎材的使用场合测得。各项数值会根据材料的物理性能不同而有所变化。若材料不确定的场合，请另行商讨。

- 注1:处理能力 能力会根据材料的种类、配合比变化而变化。
- 注2:适应材料若使用记载以外的材料时,请和本公司商讨。
- 注3:粉碎材配合比率随1次计量量和计量时间的变化而变化。
- 注4:适应材料若使用记载以外的材料时,请和本公司商讨。

The recorded value is measured in the use of the raw materials with the bulk density of 0.65a/cm³ and the crushed materials with the bulk density of 0.29g/cm³.The values vary according to the physical properties of the materia . If the materials are uncertain, please discuss it separately.

- Note 1: processing capacity the capacity will vary according to the type of material and mix ratio.
- Note 2: please consult with our company when using materials other than those recorded.
- Note 3: the ratio of grinding materials varies with the quantity and time of measurement.
- Note 4: please consult with our company when using materials other than those recorded.

Vertical COLOR MIXER 直立式混色机

产品特点

Product Features

- 短时间内完成均匀混料，低耗能、高效率。
- 四轮直立式设计，体积小，移动方便。
- 配用摆线针轮减速电机，噪音低、持久耐用。
- 安全保护装置，确保操作者及机器设备的安全。
- 桶盖、桶底冲压成型，配合精确，更耐用。
- 计时器可在0~30分钟之间选择混料时间。
- Fast evenly mixing, low energy consumption and high productivity.
- Small footprint and equipped with castors for movability.
- Planet-cycloid reducer is durable and low noise.
- Safety switch ensures machine operates only when the lid is closed.
- The lid and barrel bottom are press-formed for precise alignment and durability.
- Timer able to set within 0-30 minutes

立式桨叶

Vertical Paddles

全不锈钢桨叶，结构科学、合理在工作中可充分搅拌原料，且将负载减到最小，省时、省电；采用优质不锈钢材料，高强度，清洗方便。

Paddies can mix materials completely and evenly, and they also minimize load, save time and power consumption. Paddies are made of premium stainless steel, which has high strength and is easy to clean.



技术参数 Sechnical parameter

型号Model	马达功率 Motor power (W)	装料量 Volume (KG)	混色桶直径 Tank Diameter (MM)	机械尺寸 Dimensions (L×W×H)	重量 Gross weight (KG)
TMW-500	1500	50	610	790×850×910	130
TMW-1000	3000	100	730	980×980×1130	180
TMW-2000	4000	150	870	1000×1080×1230	280
TMW-3000	5000	200	1000	1250×1300×1390	320

Blending SILO 螺杆式混色机

产品特点

Product Features

- 螺旋循环搅拌使得原料混合更加均匀、快速。
- 适用于各种塑料原料与色母的混合搅拌，新、旧料及色母混合则效果更佳。
- 设备与原料所接触部分的材料皆为全不锈钢制作，清洗容易，避免锈蚀。
- 设有电控安全保护装置，确保操作安全。
- 可订制带加热。
- Blending screw is vertically mounted for fast and even mixing.
- Suitable for all kinds of plastic materials and color masterbatches.
- Barrel and mixing screw are made of stainless steel, both of which are rust free and easy to clean.
- Equipped with power protection device to ensure operator's safety and no damage to machine.
- Drying model is optional.



技术参数 Sechnical parameter

型号Model	主机功率 Main engine power (KW)	容量 Capacity (m³)	转速 Rotating speed (r/min)	电压 Voltage (V)	外型尺寸 External Dimensions (mm)	加热管功率 Heating tube power (KW)	风机功率 Blower Power (KW)
TMWS-500	4	1	320	380	1550x1150x2550	18	0.75
TMWS-1000	5.5	2	320	380	1850x1450x2950	18	0.75
TMWS-2000	5.5	4	320	380	2250x1800x3250	18	0.75
TMWS-3000	7.5	6	320	380	2500x2050x3550	18	0.75
TMWS-5000	11	10	287	380	2900x2350x4200	24	1.1
TMWS-8000	11	16	287	380	3250x2700x4800	24	1.1
TMWS-10000	15	20	287	380	3400x2800x5200	24	1.1
TMWS-15000	18.5	30	287	380	3650x3000x6000	24	1.1

Taima

SALES NETWORK

销售网络



多年来，
我们以雄厚的技术力量，过硬的产品品质，先进的营销网络，
使台玛塑机产品在国内硕果累累。

如今，
我们在不断提高优质产品的同时，大力完善顾客服务体系。
在业务上我们正在建立起一个以国内市场为基础，
不断向国际市场拓展的市场体系。

将来，
我们将不断追寻、不断超越，
开辟下一个里程碑。

For years,
We have achieved innumerable great achievements of
Taima bearing products in the country with our strong technical force,
super product quality and advanced sales network.

Nowadays,
We always put consumers' benefits first, improving product quality as well as service system..
In business, we are establishing a market system based on domestic market
and engaged in the international market constantly.

In the future,
We will always in pursuit of and continuously make improvements for
every new milestone.