

Work Secure, Healthy and Smart

# Technology Drives Workstyle

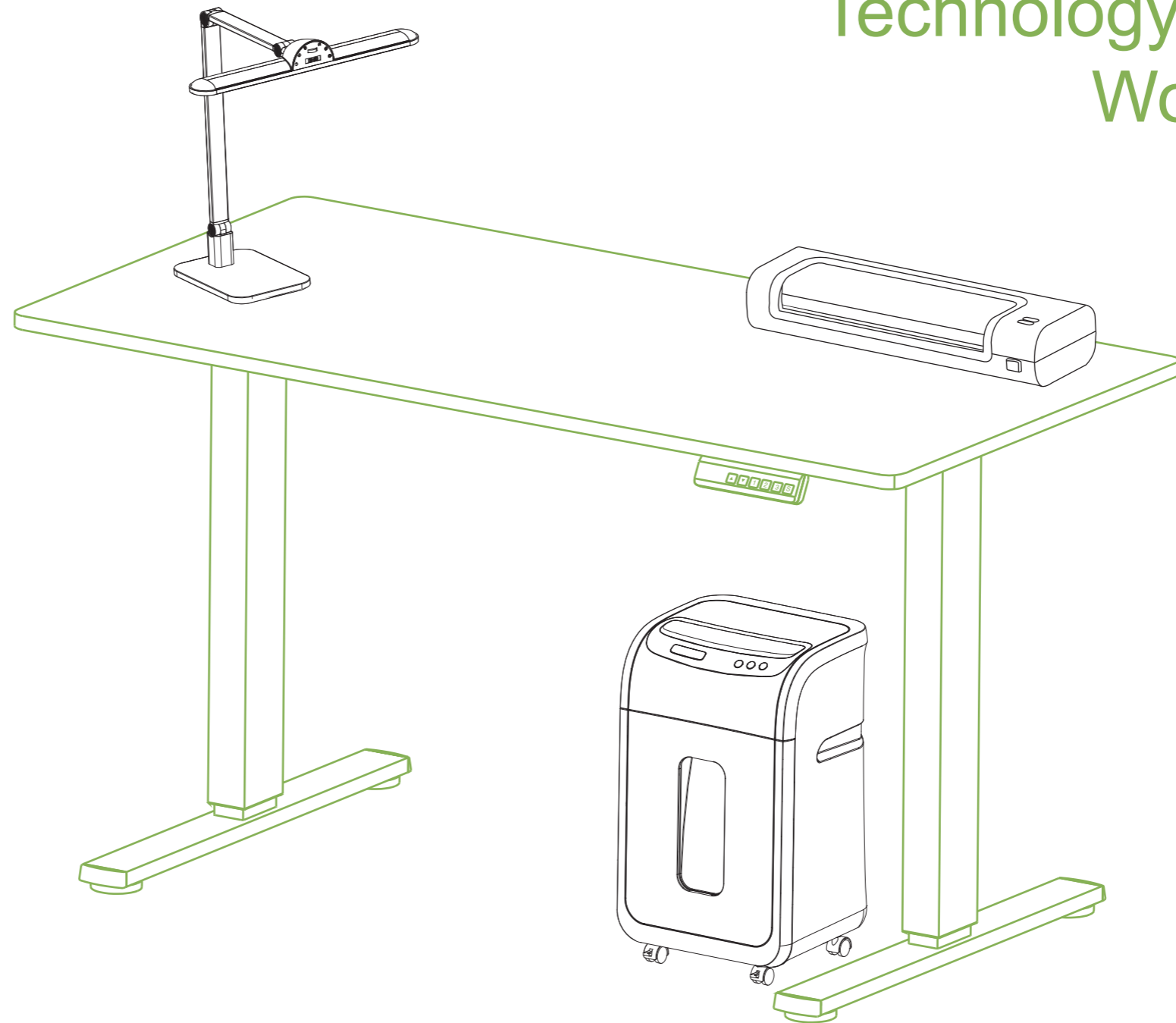

#### **Ningbo Ofitech Business Machines Co., Ltd (HQ)**

Sales & Manufacture  
Add: Kaifat Group, No.599, Qiming Road, Yinzhou Incubation,  
Ningbo, China  
Tel:+86 574-55665196  
Email: sales@SmartOfitech.com

#### **Ofitech Business Machines Inc. (USA)**

Sales & Design  
Add: #79525 West Hollywood, California, 90069  
Tel:(970) 536-5771

#### **Shenzhen Ofitech Business Machines Co.,Ltd**

Sales & Technical Development  
Add: 2F, Nanyuan Commercial Building, No.4 Minbao Road,  
Longhua District, Shenzhen, Guangdong

[www.smartofitech.com](http://www.smartofitech.com)

Follow us on



**Ofitech**<sup>®</sup>

# About Ofitech

Since

2001

We innovate, manufacture and distribute professional paper shredders, laminators, electric standing desks, Table Lamp, and related smart office electronics, with the advantages of vertical precise in-house manufacturing facilities and industry-leading technologies.

## Our Vision

Our unlimited passion for technology, services and relentless pursuit of innovation all drive us to provide our customers with creative workspace solutions, greater information security protection, increasing productivity.

## We bring you with values of

Higher quality standard  
Competitive lower price  
and a better workstyle

# Worldwide Partners Network

ODM/OEM customers all over the world



# Why Ofitech?

**52,000+(m<sup>2</sup>)**

Production Area

**250,000+**

Units shipped each month

**20+**

years in office machines development and manufacture

**100+**

Esteemed clients worldwide

**50+**

Countries within our sales network

**5+**

Factories/branches/offices  
In China and USA

**<25**

Days lead time from PO to CRD



**2022**

Smart Ofitech initiated

**2020**

Electric standing desks developed

**2018**

Lean Production system accomplished

**2014**

Ranked Green Supplier to Walmart

**2013**

Laminators developed

**2012**

Renamed as Ofitech to fully focus on office electronics market

**2008**

Shredder lineup ranges from home, office use to commercial grade

**2003**

Industrial Park constructed, covering land area of 133,400 m<sup>2</sup>

**2002**

First generation of manual shredders developed

**2001**

Established in Ningbo, China

Work Smart

# Smart Office Solutions



Work Healthy

# Standing Desk

## High Stability. Full Focus

ultra-Stable Electric Standing Desk Series



Agile Use  
Single Leg

Home Office  
Single Motor

Small Office  
Dual Motor

Large Office  
L-shape/H-Shape

Commercial Office  
Variable frames

## Electric Standing Desk

### Single Motor for Home Office: ES1

Electric Height Adjustable Desk, Single Motor, 2 Stages, robust and steady

Lifting weight	80KG
Lifting Range	730-1210mm
Tabletop	Particle Board
Column Size	4575x4070mm
Frame	2 Stages
Frame color	Black/White/Gray
Voltage	100~240V/50-60Hz
speed	25mm/s
Panel	3 Memory Settings
Anti-collision	Available
Safety	UL, FCC,CE

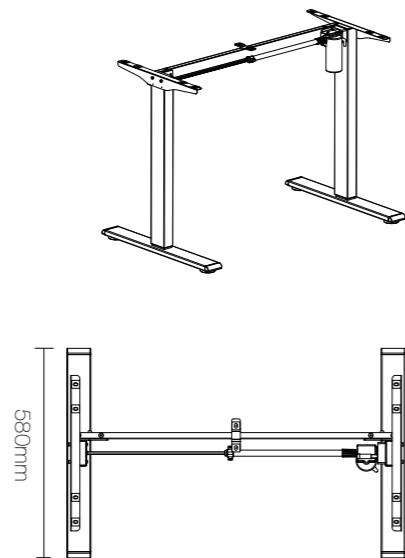
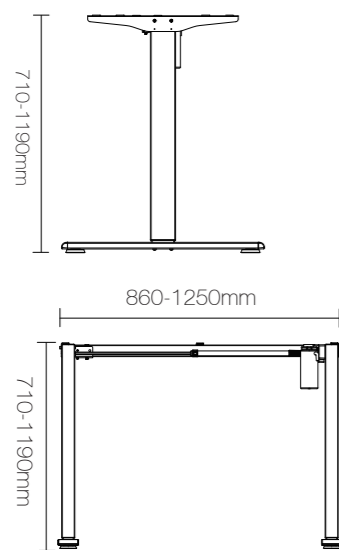

## Electric Standing Desk

### Household and Office use desk: ES-07-4P

4 pieces-Sliced desktop, Height adjustable Electronic Desk, single motor, Robust and steady

Lifting weight	70KG
Material	Iron, particle board, plastic
Motor	Single Motor
Adjustable height range	720-1180mm
Table foot size	595x75mm
Column size	63.5x70mm
Voltage	100~240V/50-60Hz
speed	20mm/s
Panel	3 Memory Settings
Anti-collision	Available
Safety	UL, FCC, CE



## Electric Standing Desk

### Dual Motor for Home Office: ED1

Electric Height Adjustable Desk, Dual Motor, 2 Stages, robust and steady

Lifting weight	100KG
Lifting Range	730-1210mm
Tabletop	Particle Board
Column Size	4575x5080mm
Frame	2 Stages
Frame color	Black/White/Gray
Voltage	100~240V/50-60Hz
speed	32mm/s
Panel	3 Memory Settings
Anti-collision	Available
Safety	UL, CE, FCC



## OFFICE MACHINE For Health

### Dual Motor Desk Frame: ED1-F



Quiet and Smooth: <50dB



Height Range: 710-1190mm



Maximum Load Capacity: 100KG



Maximum Lifting Speed: 28mm/s

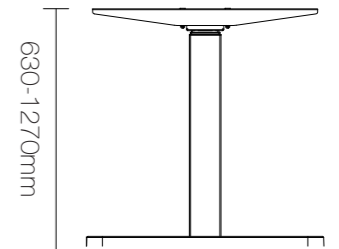
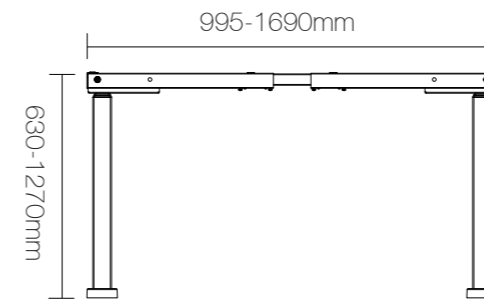
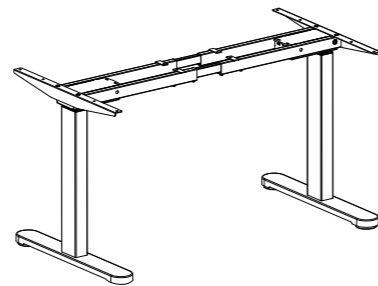
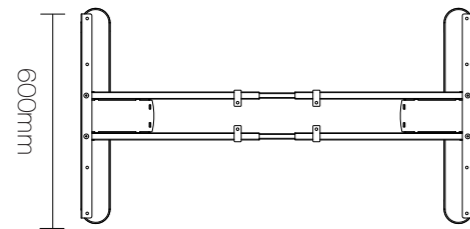

## Electric Standing Desk

### Tri-Motor for Home Office: ET1

Electric Height Adjustable Desk, Three Motors, 3 Stages, robust and steady

Lifting weight	150KG
Lifting Range	650-1290mm
Tabletop	Particle Board
Column Size	4070*4575*5080mm
Frame	3 Stages
Frame color	Black/White/Gray
Voltage	100~240V/50-60Hz
speed	38mm/s
Panel	3 Memory Settings
Anti-collision	Available
Safety	UL, CE, FCC



## OFFICE MACHINE For Health

### Tri-Motor Desk Frame: ET1-FL-Shape



Quiet and Smooth: <50dB



Height Range: 630-1270mm



Maximum Load Capacity: 150KG



Maximum Lifting Speed: 38mm/s

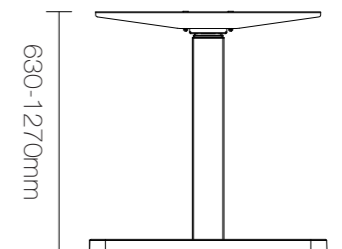
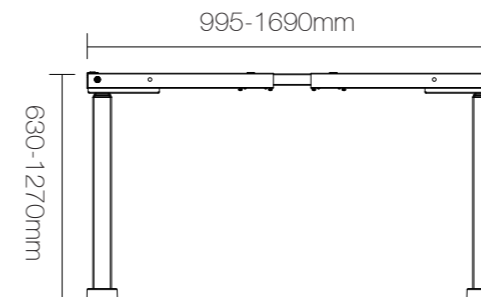
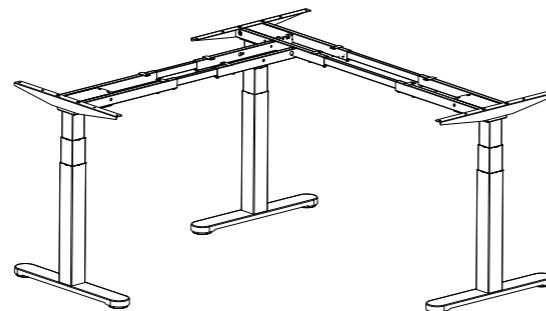
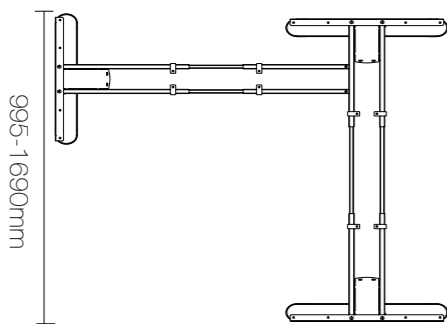



## Electric Standing Desk

### Four Motor for Home Office: EQ1 H-Shape

Electric Height Adjustable Desk, Four Motors, 3 Stages, robust and steady

Lifting weight	100KG
Lifting Range	650-1290mm
Tabletop	Particle Board
Column Size	70*65*60mm
Frame	3 Stages
Frame color	Black/White/Gray
Voltage	100~240V/50-60Hz
speed	38mm/s
Panel	3 Memory Settings
Anti-collision	Available
Safety	UL,CE,FCC



## OFFICE MACHINE For Health

### Four Motors Desk Frame: EQ1-FH-Shape



Quiet and Smooth:<50dB



Height Range: 630-1270mm



Maximum Load Capacity:100KG



Maximum Lifting Speed:38mm/s

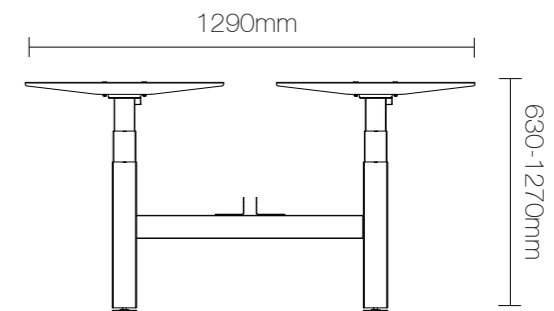
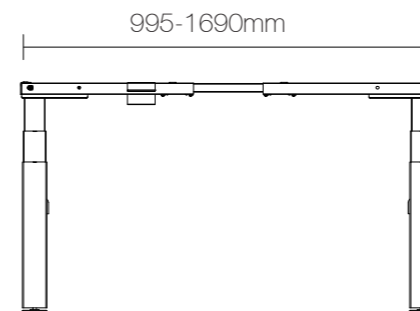
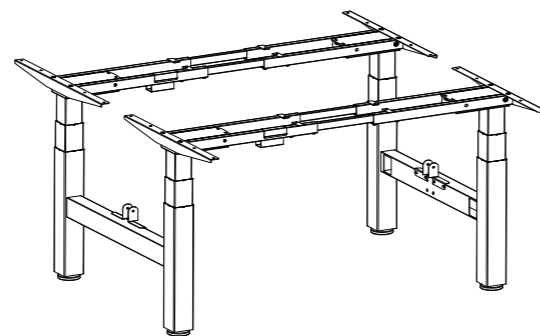
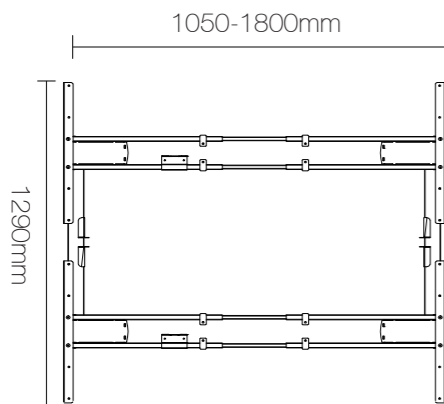

## Electric Standing Desk

### Single Leg Desk Electric: EA1

Electric Height Adjustable Desk, Single Motor, 2 Stages, robust and steady

Lifting weight	50KG
Lifting Range	630-1270mm
Tabletop	Particle Board
Column Size	7070*6565*6060mm
Frame	2 Stages
Frame color	Black/White/Gray
Voltage	100~240V/50-60Hz
speed	38mm/s
Panel	3 Memory Settings
Anti-collision	Available
Safety	UL,CE, FCC

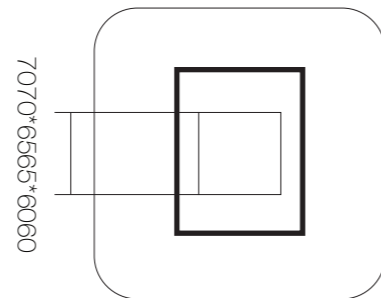
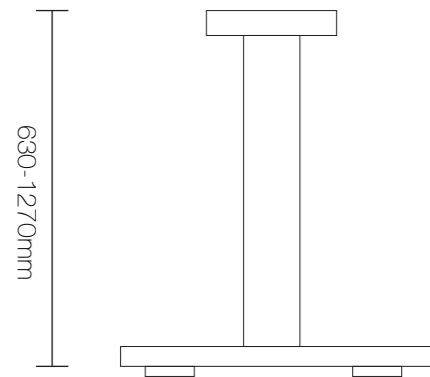

## OFFICE MACHINE For Health

### Single Leg Desk Air-Lift: MA1

Lifting weight	25KG
Lifting Range	750-1120mm
Tabletop	Particle Board
Column Size	7070*6060mm
Frame	2 Stages
Frame color	Black/White/Gray

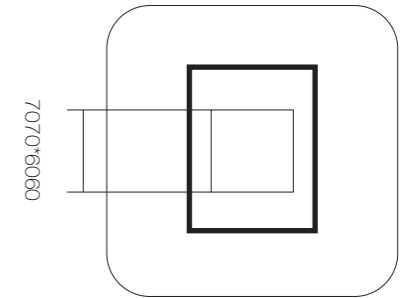
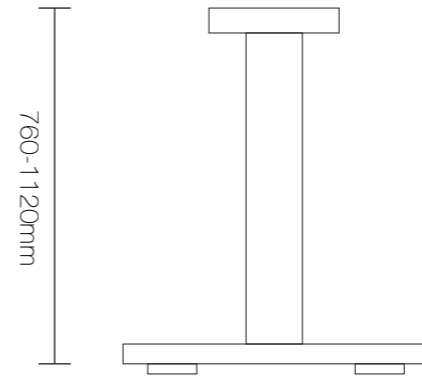

## Electric Standing Desk

### Glasstop for Home Office : EG1-W

Electric Height Adjustable Desk, Single Motor, 2 Stages , robust and Steady

Lifting weight	50kg
Lifting Range	720-1180
Tabletop	glass
Column Size	6060*5555
Frame	2 stage
Frame color	black/white/grey
Voltage	100-240V/50-60Hz
speed	20mm/s
Panel	3 Memory setting
Anti-collision	available
Safety	UK,CE,FCC

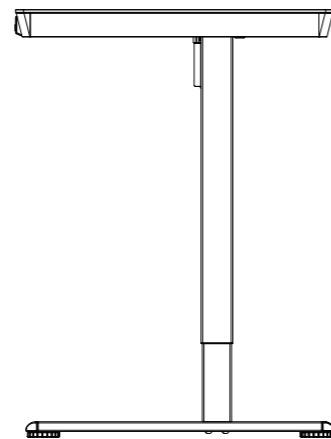
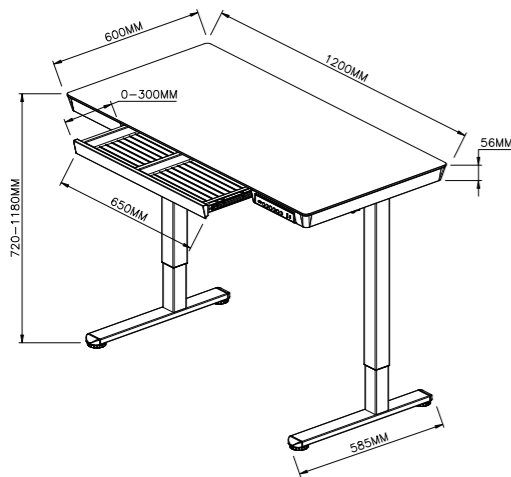

## Electric Standing Desk

### Stand Up Desk with Double Drawer:ES2-ST

Electric Height Adjustable Desk,with Storage Shelf, Single motor,2 stages,robust and Steady

Lifting weight	60KG
Lifting Range	730-1210mm
Tabletop	Particle Board
Column Size	4575x4070mm
Frame	2 Stages
Frame color	black/white/grey
Voltage	100~240V/50-60Hz
speed	25mm/s
Panel	3 Memory Settings
Anti-collision	Available
Safety	UL, FCC,CE

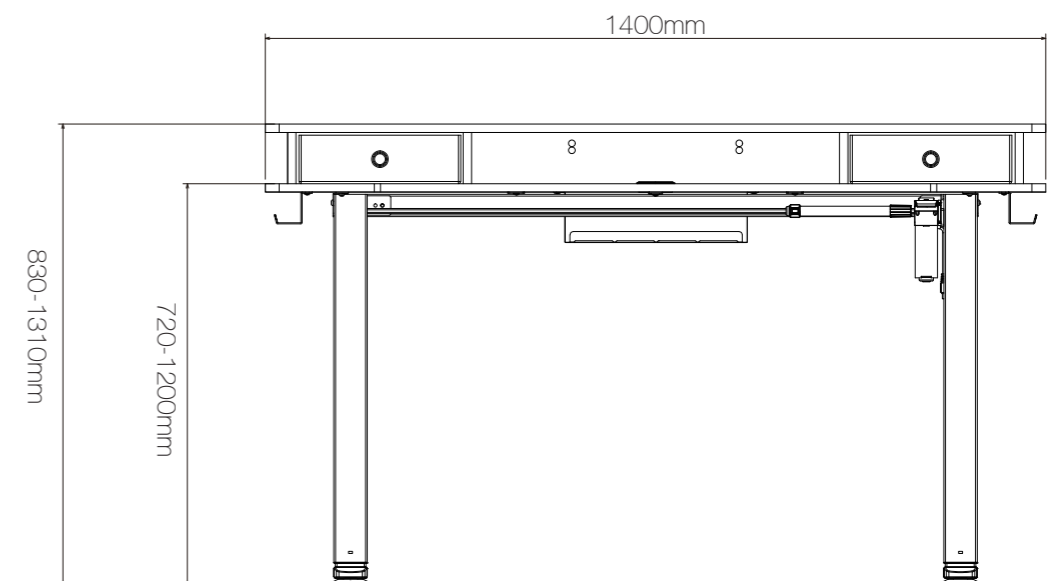

## Electric Standing Desk

### Electric Lifting Gaming Desk: EGM1

Professional gaming e-sport experience  
One-button electric lift, RGB,armor atmosphere lighting effect

Lifting weight	70KG
Lifting Range	730-1210mm
Tabletop	Particle Board
Column Size	4575x4070mm
Frame	2 Stages
Frame color	Black/Red/white
Voltage	100~240V/50-60Hz
speed	25mm/s
Panel	3 Memory Settings
Anti-collision	Available
Safety	UL, FCC,CE

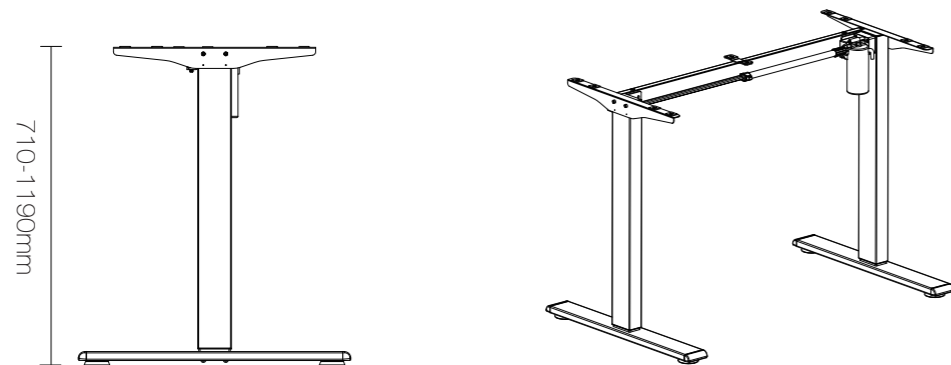

## Electric Standing Desk

### Electric Lifting Gaming Desk: EGM2

Professional gaming e-sport experience  
One-button electric lift, RGB,armor atmosphere lighting effect

Lifting weight	70KG
Lifting Range	730-1210mm
Tabletop	Particle Board
Column Size	4575x4070mm
Frame	2 Stages
Frame color	Black/Red/white
Voltage	100~240V/50-60Hz
speed	25mm/s
Panel	3 Memory Settings
Anti-collision	Available
Safety	UL, FCC,CE

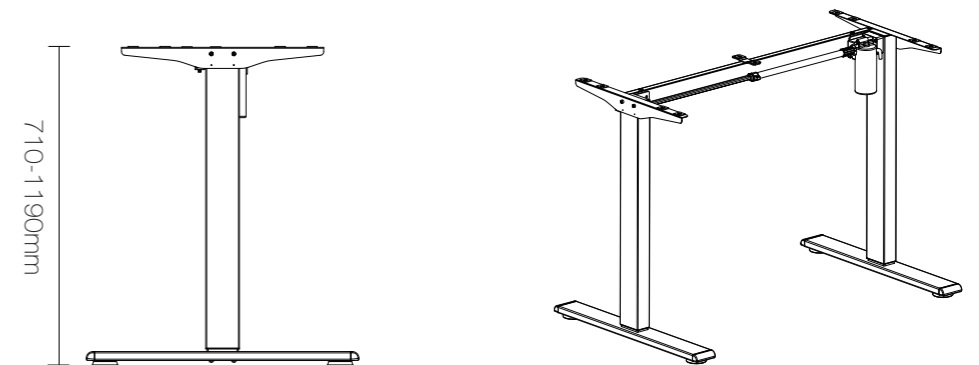

## Electric Standing Desk

### Laptop Folding Table: MF1

Manual height adjustable, Folding Table with USB, drawer, bookshelf

Lifting weight	20KG
Material	Aluminium alloy +MDF
Size	600*400*270-400mm
Color	White/Gray/Black/Oak
Other features	USB, drawer, bookshelf
Packing	5pcs per carton
Box size	650*430*100mm
Carton size	670*550*470mm
Net Weight	3.0KG
Carton Weight	17KG



## Electric Standing Desk

### Laptop Folding Table : MF2

Portable Folding Laptop Table with two USB Fans, height adjustable

Lifting weight	15KG
Material	Aluminium alloy +ABS
Size	420*260(480*260)mm
Color	Black/Pink
Other features	Two Fan
Packing	10pcs per carton
Box size	530*270*45mm
Carton size	550*480*290mm
Net Weight	1.35KG
Carton Weight	15KG



# Qualification & Certifications

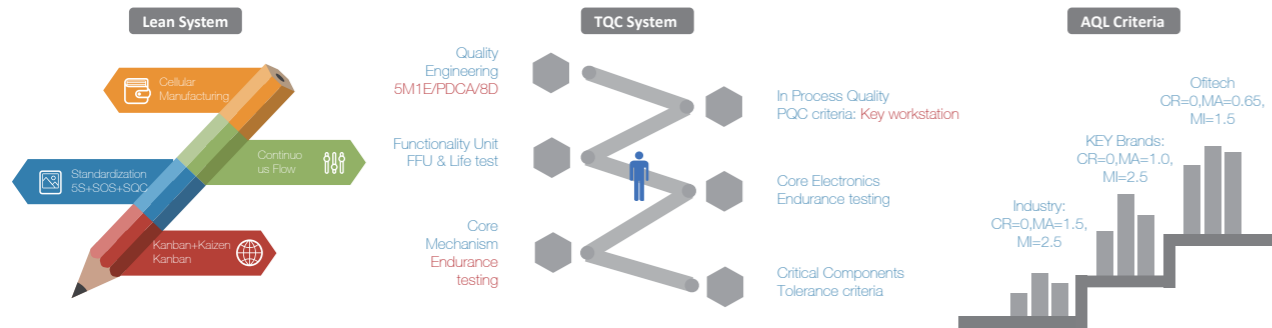

## Factories Certified for

- ISO9001:2015 Quality system
- ISO14001:2015 Environment system
- BSCI Ethical System

## Products Certified by

