

J4V Series Solenoid Valve



Valve

- J4V
- J4V100
- J4V200
- J4V300
- J4V400
- Manifold
- JSY
- Terminal
- JVT
- JEL
- MVSD
- VF
- NAMUR
- 551
- JEL10
- 3VJZF
- Diaphragm
- JELVD
- 3V1
- Coil
- 2P
- 2V
- 2W
- 2W(big)
- 2L
- VX
- PU
- PU225
- 2Q
- JEL5404
- JEL6213
- Pulse
- JEL.JZF
- 4H
- TSV
- MPV
- 4HV
- HV, K
- 4R
- 4F210
- FV
- MSV
- JM
- ASC, RE
- QE, QEA
- ST
- HSV

Features

1. The Anti-friction seal is added at both ends of the valve spool to make the valve spool more stable during the switching process and increase the valve life time.
2. Seals original imported from Japan; Optimize valve body inner flow path; Maximum increase the air flow area.
3. Valve piloted seat is from taiwan, the surface design with 5 pcs stripe; increased the strength of manual ride spindle; the appearance is more distinctive (applied appearance patent).
4. The valve body surface treatment adopts a new environmental protection process.
5. Fully automated assembling & test line with good product consistency.

Internal Structure

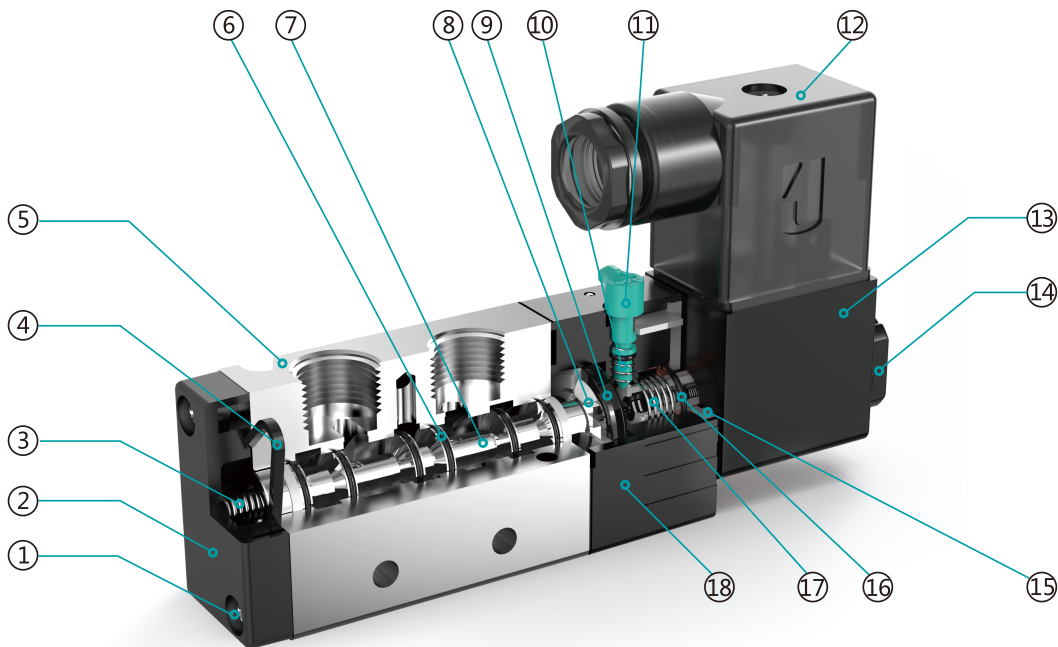

Parts

Number	Name	Number	Name	Number	Name
1	Cross slot pan screw	7	Valve spool	13	Coil
2	Back cover	8	Piston	14	Coil nut
3	Spring	9	Y ring	15	Fix plate
4	Anomalous seal	10	Spring	16	O ring
5	Valve body	11	Manual ride spindle	17	Plunger
6	Flat ring	12	Terminal	18	Pilot seat

Improvement of Flow Performance Indicator

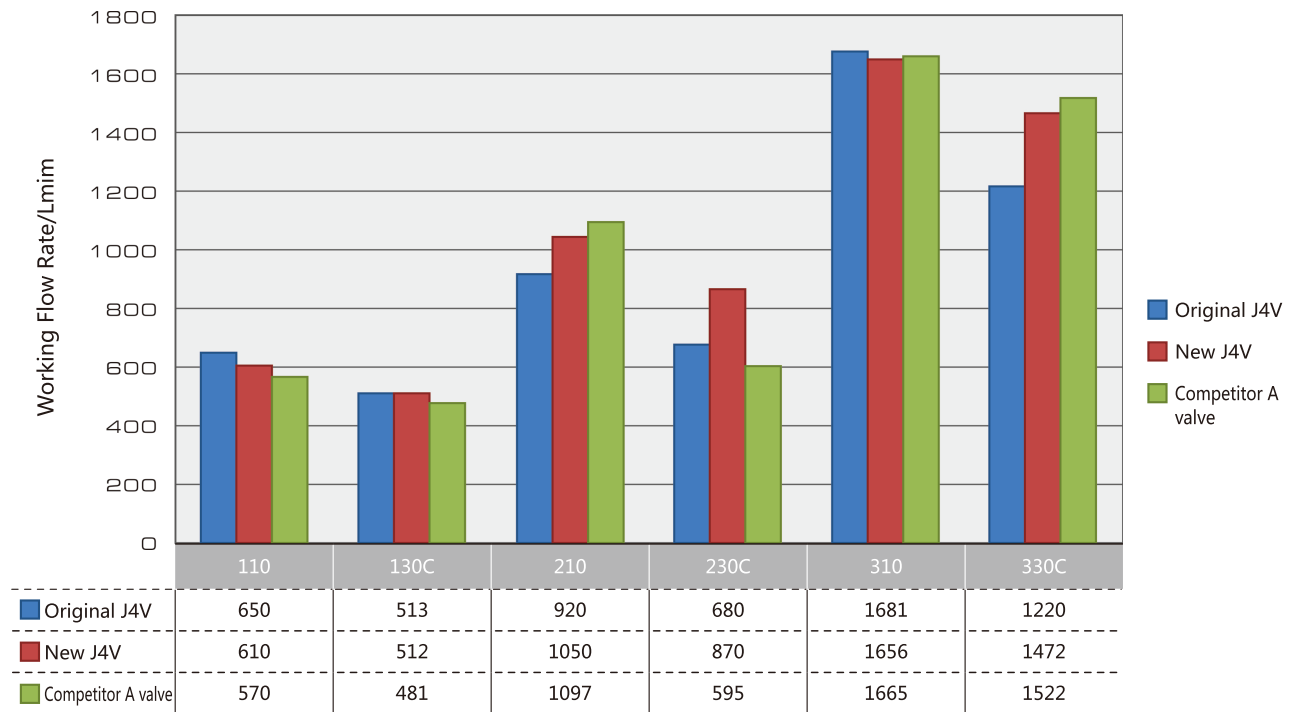

Improvement of Life-time

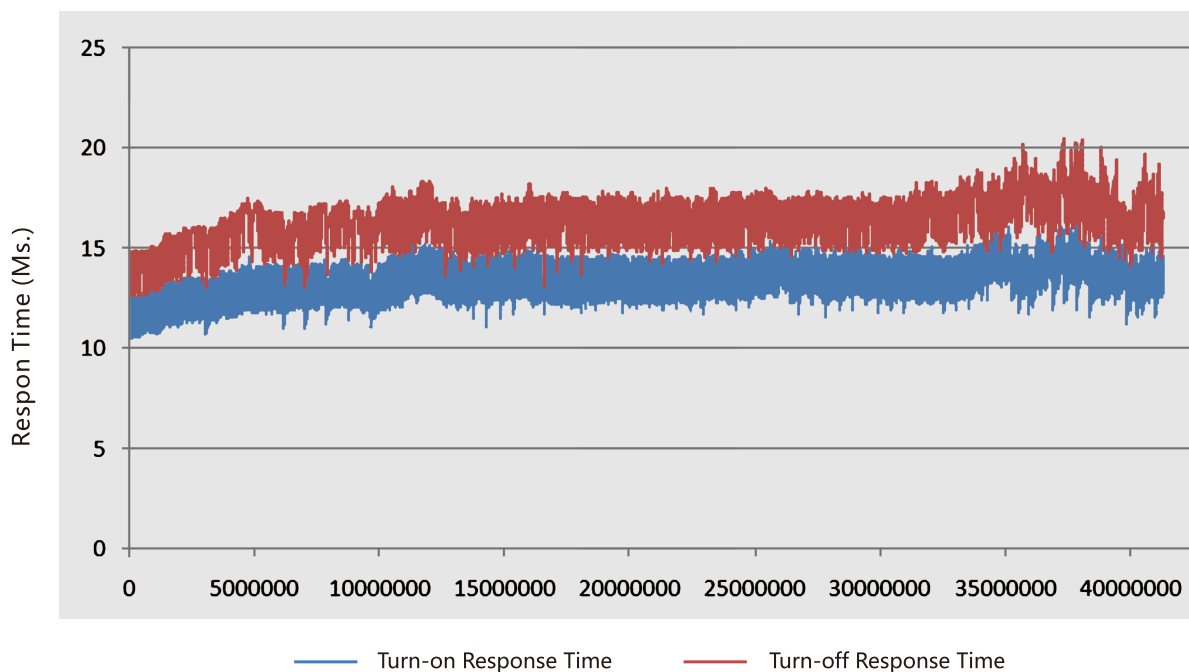

The chart shows that the response time of the solenoid valve is within 25 milliseconds. The response time of the solenoid valve is minor difference after 40 million lifetime tests.

Valve

- J4V
- J4V100
- J4V200
- J4V300
- J4V400
- Manifold
- JSY
- Terminal
- JVT
- JEL
- MVSD
- VF
- NAMUR
- 551
- JEL10
- 3VJZF
- Diaphragm
- JELVD
- 3V1
- Coil
- 2P
- 2V
- 2W
- 2W(big)
- 2L
- VX
- PU
- PU225
- 2Q
- JEL5404
- JEL6213
- Pulse
- JELJZF
- 4H
- TSV
- MPV
- 4HV
- HV, K
- 4R
- 4F210
- FV
- MSV
- JM
- ASC, RE
- QE, QEA
- ST
- HSV

J4V300 Series Solenoid Valve, Air Pilot Valve



4A310-10



J4V310-10



J4V310-10B

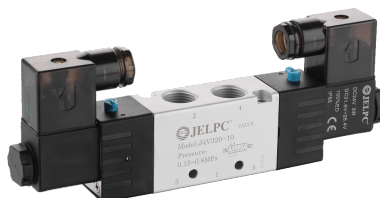

J4V320-10



J4V330C-10

Ordering Code

J4V	3	10	10	B	AC220V	W	F
Specification	Series Code	Coil and Type	Port Size	Connection and Initial status	Standard Voltage	Wiring	Joint
J4V: 5/2 (3) way solenoid valve 4A: 5/2 (3) way air pilot valve J3V: 3/2 way solenoid valve 3A: 3/2 way air pilot valve	300 Series	10: Single coil 20: Double coil 30C: Mid-position closed 30E: Mid-position exhausted 30P: Mid-position pressed	08: 1/4" 10: 3/8"	Blank: Threaded B: Sub-plated mounted (for 5/2,5/3 way only) NC: 3/2 way normal close NO: 3/2 way normal open	DC12V DC24V AC24V 50Hz/60Hz AC110V 50Hz/60Hz AC220V 50Hz/60Hz	Blank: Brown with light terminal W: Lead wire	1F-20F

Specification

Model	J4V310-08	J4V320-08	J4V330C-08	J4V330E-08	J4V330P-08	J4V310-10	J4V320-10	J4V330C-10	J4V330E-10	J4V330P-10
Valve Type	5/2 way		5/3 way			5/2 way		5/3 way		
Effective Cross Section Area	25mm ² (CV=1.40)		18mm ² (CV=1.00)			30mm ² (CV=1.68)		18mm ² (CV=1.00)		
Model	J3V310-08	J3V320-08	3A310-08	3A320-08	J3V310-10	J3V320-10	3A310-10	3A320-10		
Valve Type	3/2 way									
Effective Cross Section Area	25mm ² (CV=1.40)					30mm ² (CV=1.68)				
Port Size	Inlet, Outlet, Exhaust Port = G 1/4"					Inlet, Outlet = G 3/8" Exhaust Port = G 1/4"				
Working Medium	40 Micron Filtered Air									
Operation	Internal piloted									
Working Pressure	0.15 ~ 0.8MPa									
Max. Test Pressure	1.2MPa									
Ambient Temperature	-20 ~ 70°C									
Operating Voltage Tolerance	±10%									
Power Consumption	AC: 3.5VA DC: 3.0W									
Connector Protection	F Class, IP 65									
Wiring / Connector	Cable / Lead Wire or DIN Connector									
Switching Frequency	5 Cycles / Sec.									
Response Time	0.05秒									

Valve

J4V

J4V100

J4V200

J4V300

J4V400

Manifold

JSY

Terminal

JVT

JEL

MVSD

VF

NAMUR

551

JEL10

3VJZF

Diaphragm

JELVD

3V1

Coil

2P

2V

2W

2W(big)

2L

VX

PU

PU225

2Q

JEL5404

JEL6213

Pulse

JELJZF

4H

TSV

MPV

4HV

HV, K

4R

4F210

FV

MSV

JM

ASC, RE

QE, QEA

ST

HSV

J4V300 Series

Solenoid Valve, Air Pilot Valve



- Valve
- J4V
- J4V100
- J4V200
- J4V300**
- J4V400
- Manifold
- JSY
- Terminal
- JVT
- JEL
- MVSD
- VF
- NAMUR
- 551
- JEL10
- 3VJZF
- Diaphragm
- JELVD
- 3V1
- Coil
- 2P
- 2V
- 2W
- 2W(big)
- 2L
- VX
- PU
- PU225
- 2Q
- JEL5404
- JEL6213
- Pulse
- JELJZF
- 4H
- TSV
- MPV
- 4HV
- HV, K
- 4R
- 4F210
- FV
- MSV
- JM
- ASC, RE
- QE, QEA
- ST
- HSV

Overall Dimension

J4V310-08

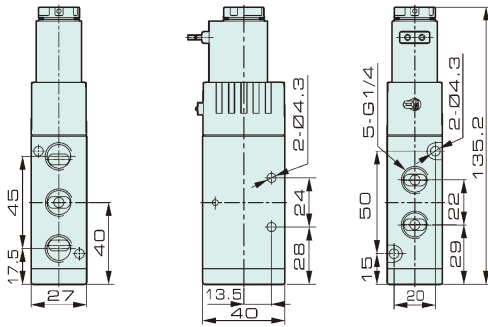

J4V310-08

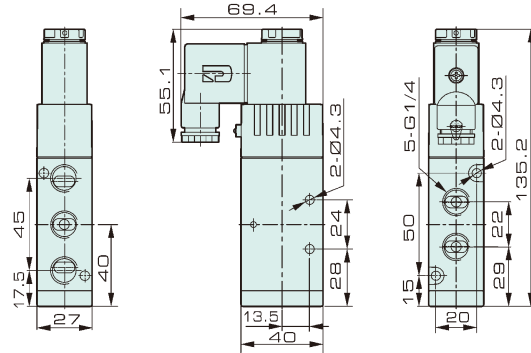

J4V320-08

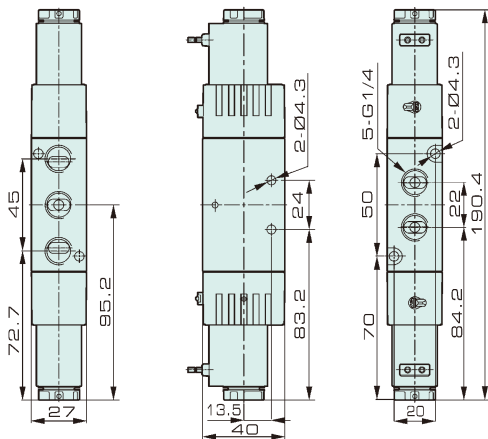

J4V320-08

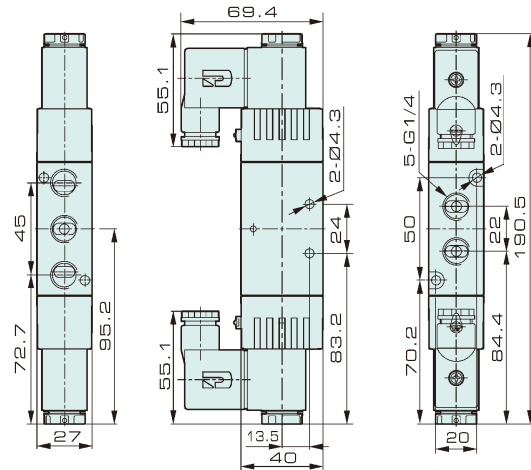

J4V330-08

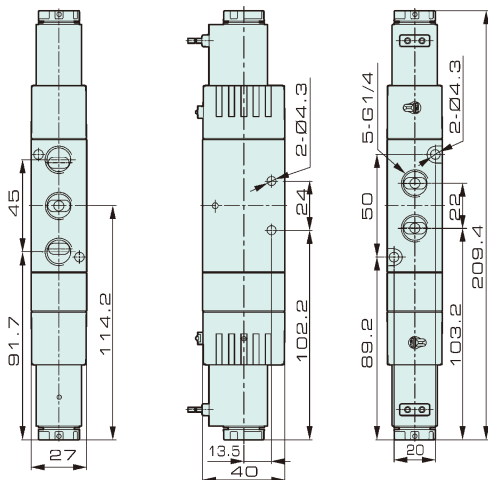
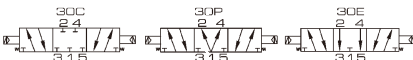

J4V330-08

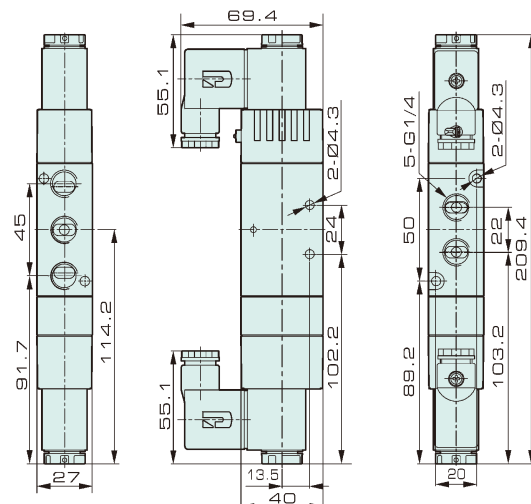
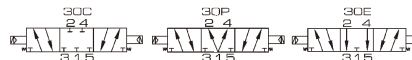

Overall Dimension

J4V310-10

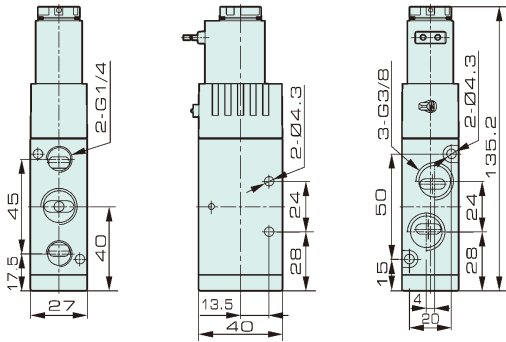

J4V310-10

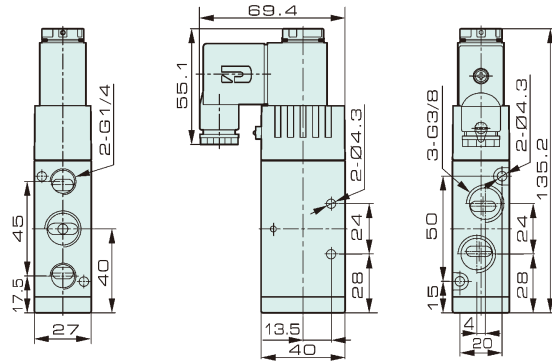

J4V320-10

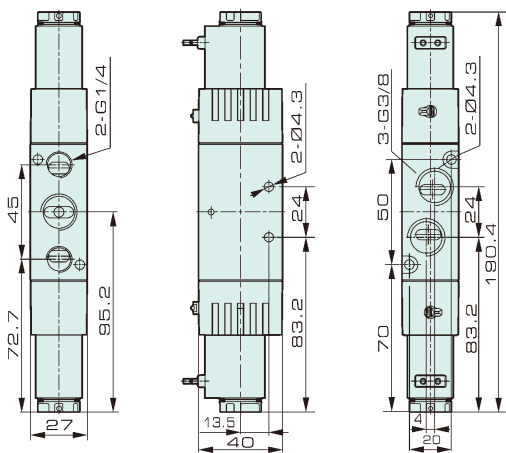

J4V320-10

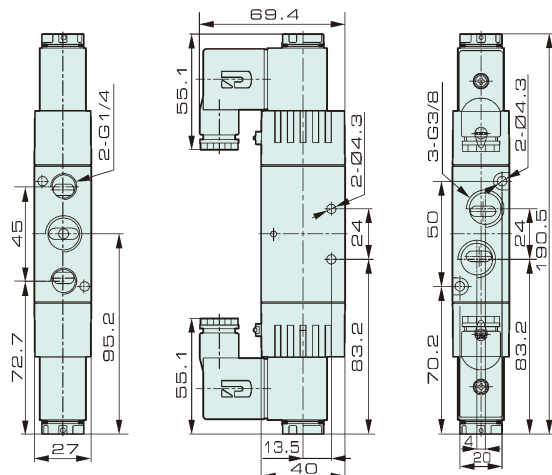

J4V330-10

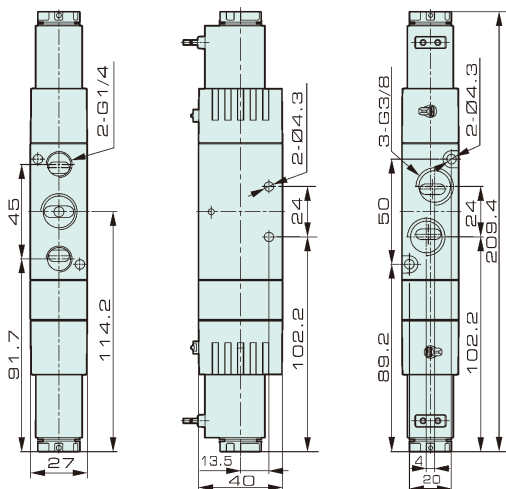

J4V330-10

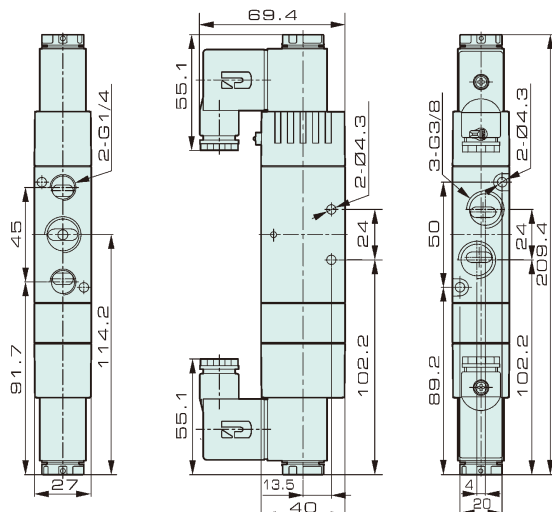

Valve

J4V

J4V100

J4V200

J4V300

J4V400

Manifold

JSY

Terminal

JVT

JEL

MVSD

VF

NAMUR

551

JEL10

3VJZF

Diaphragm

JELVD

3V1

Coil

2P

2V

2W

2W(big)

2L

VX

PU

PU225

2Q

JEL5404

JEL6213

Pulse

JELJZF

4H

TSV

MPV

4HV

HV, K

4R

4F210

FV

MSV

JM

ASC, RE

QE, QEA

ST

HSV

J4V300 Series

Solenoid Valve, Air Pilot Valve



Valve

J4V

J4V100

J4V200

J4V300

J4V400

Manifold

JSY

Terminal

JVT

JEL

MVSD

VF

NAMUR

551

JEL10

3VJZF

Diaphragm

JELVD

3V1

Coil

2P

2V

2W

2W(big)

2L

VX

PU

PU225

2Q

JEL5404

JEL6213

Pulse

JEL.JZF

4H

TSV

MPV

4HV

HV, K

4R

4F210

FV

MSV

JM

ASC, RE

QE, QEA

ST

HSV

J4V310-08B

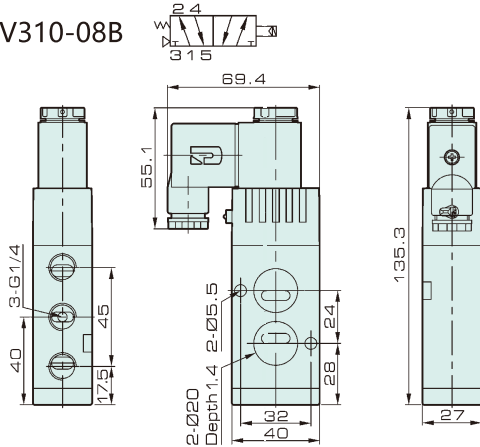

J4V310-10B

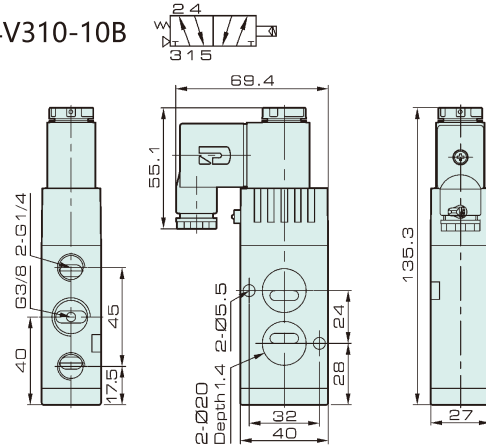

J4V320-08B

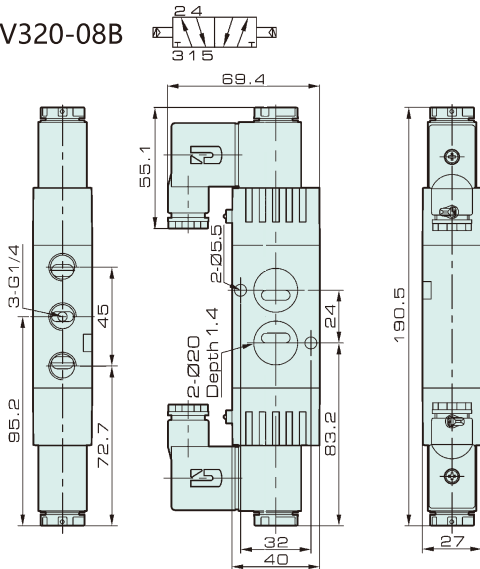

J4V320-10B

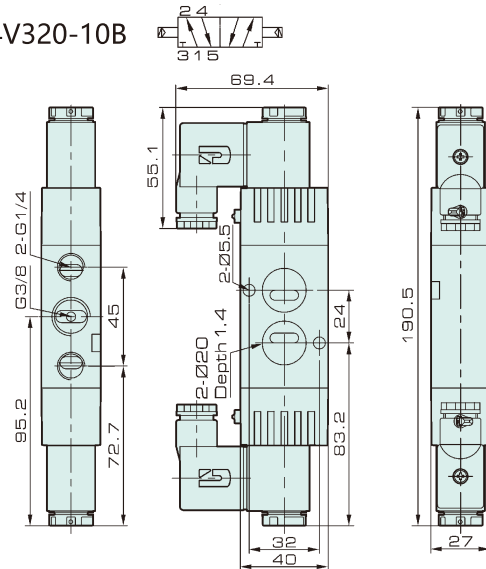

J4V330-08B

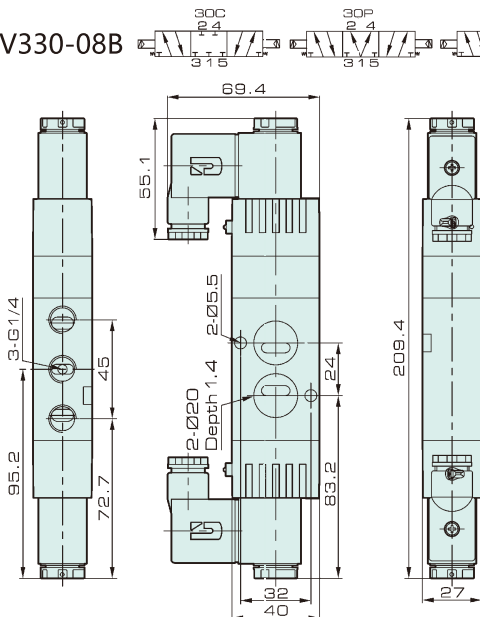

J4V330-10B

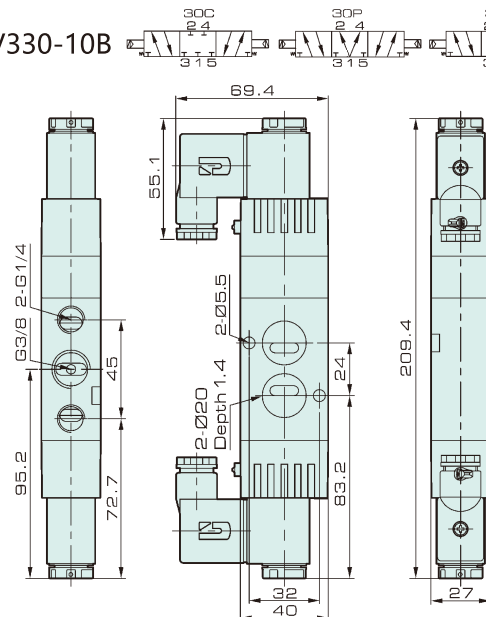

4A310-08

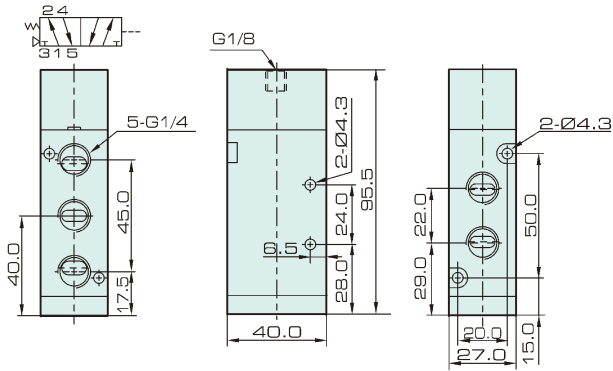

4A310-10

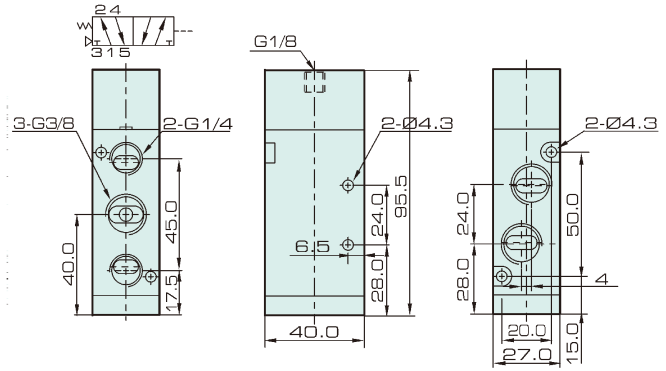

4A320-08

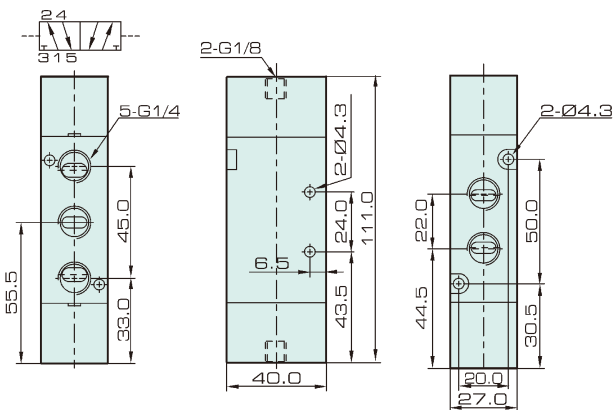

4A320-10

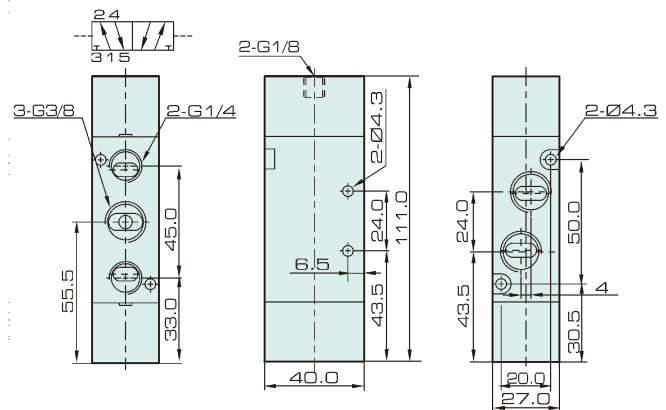

4A330-08

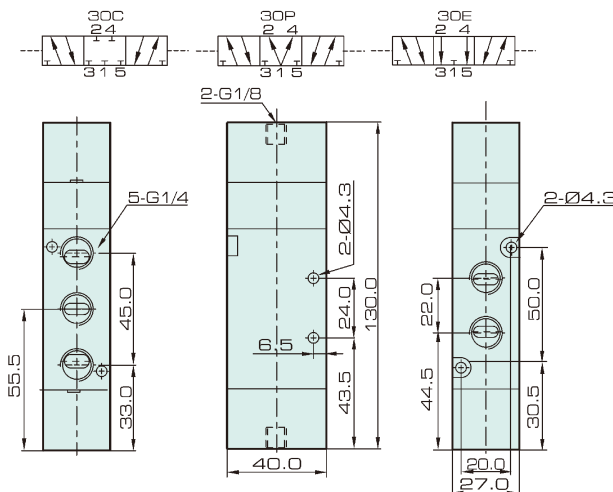

4A330-10

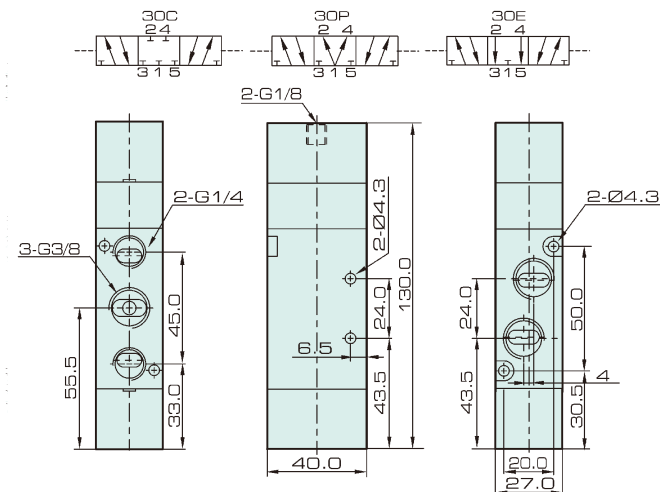

Valve

J4V

J4V100

J4V200

J4V300

J4V400

Manifold

JSY

Terminal

JVT

JEL

MVSD

VF

NAMUR

551

JEL10

3VJZF

Diaphragm

JELVD

3V1

Coil

2P

2V

2W

2W(big)

2L

VX

PU

PU225

2Q

JEL5404

JEL6213

Pulse

JELJZF

4H

TSV

MPV

4HV

HV, K

4R

4F210

FV

MSV

JM

ASC, RE

QE, QEA

ST

HSV

J4V300 Series

Solenoid Valve, Air Pilot Valve



Valve

J4V

J4V100

J4V200

J4V300

J4V400

Manifold

JSY

Terminal

JVT

JEL

MVSD

VF

NAMUR

551

JEL10

3VJZF

Diaphragm

JELVD

3V1

Coil

2P

2V

2W

2W(big)

2L

VX

PU

PU225

2Q

JEL5404

JEL6213

Pulse

JEL.JZF

4H

TSV

MPV

4HV

HV, K

4R

4F210

FV

MSV

JM

ASC, RE

QE, QEA

ST

HSV

• J3V310-08

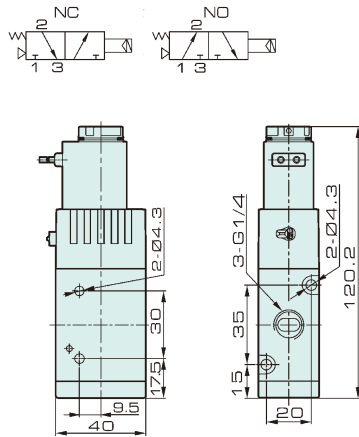

• J3V310-08

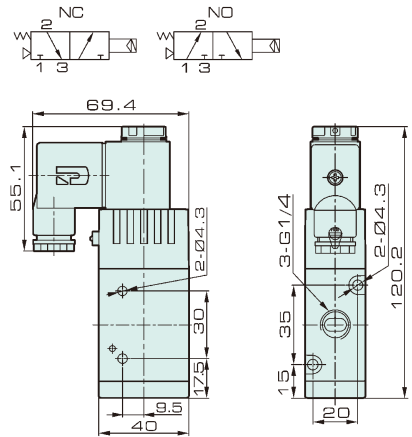

• J3V320-08

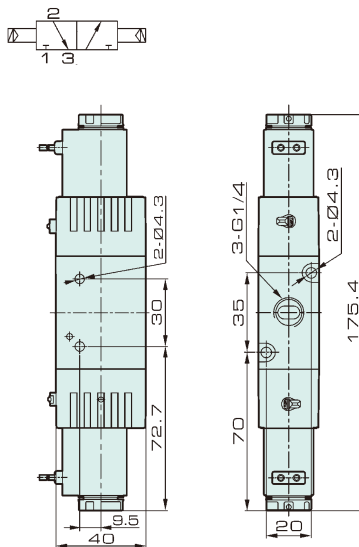

• J3V320-08

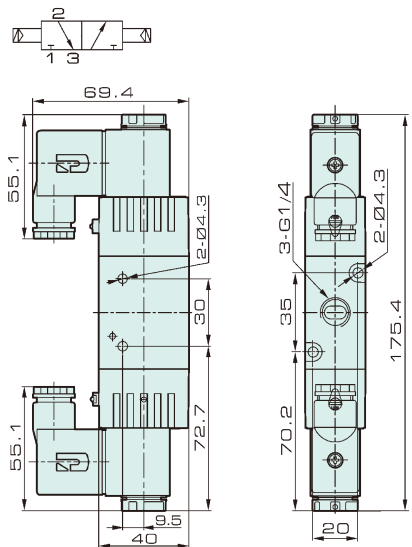

• J3V310-10

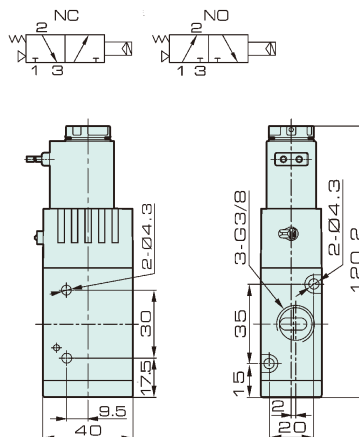

• J3V310-10

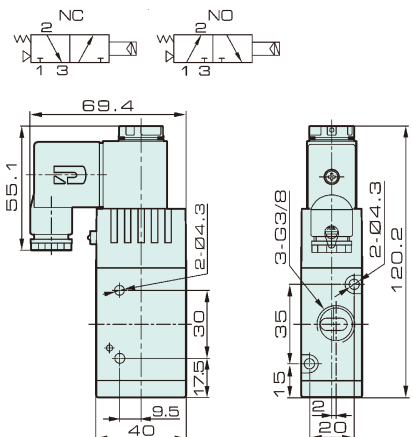

• J3V320-10

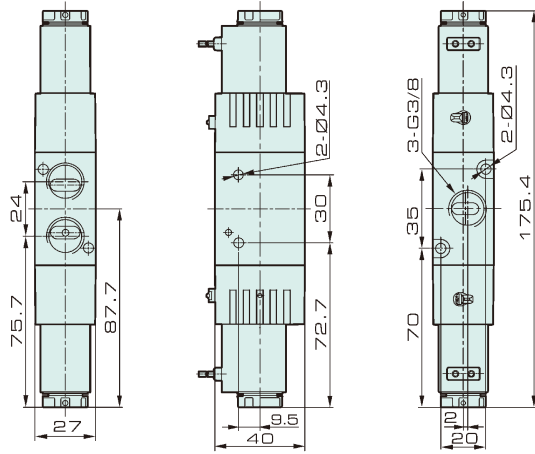
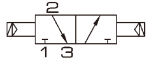

• J3V320-10

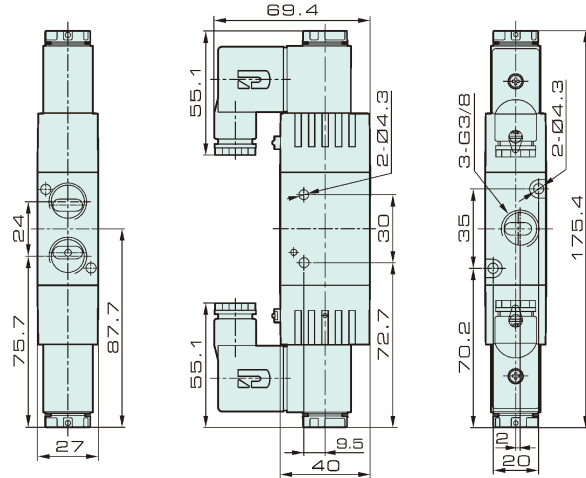
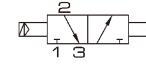

• 3A310-08

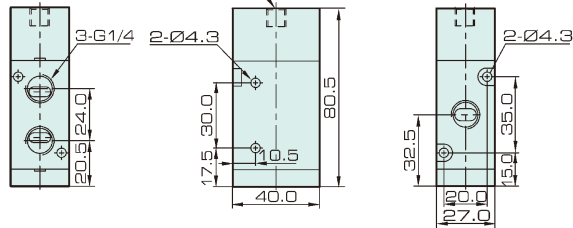
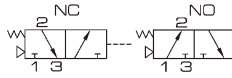

• 3A310-10

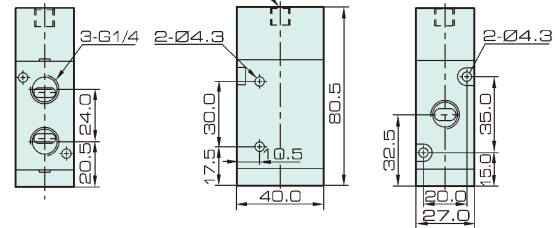
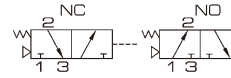

• 3A320-08

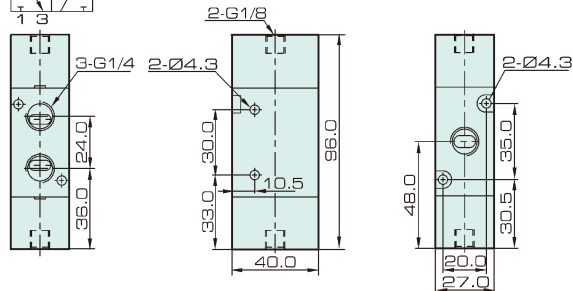
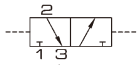

• 3A320-10

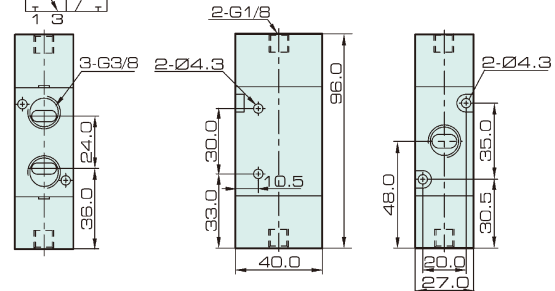
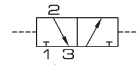

Valve

J4V

J4V100

J4V200

J4V300

J4V400

Manifold

JSY

Terminal

JVT

JEL

MVSD

VF

NAMUR

551

JEL10

3VJZF

Diaphragm

JELVD

3V1

Coil

2P

2V

2W

2W(big)

2L

VX

PU

PU225

2Q

JEL5404

JEL6213

Pulse

JELJZF

4H

TSV

MPV

4HV

HV, K

4R

4F210

FV

MSV

JM

ASC, RE

QE, QEA

ST

HSV