



国家级绿色供应链示范企业  
国家级高新技术企业

# 电缆附件和在线监测装置

CABLE ACCESSORIES AND  
ONLINE MONITORING DEVICES

专注电力 服务全球  
FOCUS ON POWER · SERVE THE WORLD

**EONGE** 专注电力 服务全球  
FOCUS ON POWER · SERVE THE WORLD  
上海永锦电气技术股份有限公司

总部地址：上海市松江区洞泾镇洞业路508号(松江大学城)  
电话(Tel): 021-57670550 57670660-8828  
传真(Fax): 021-57670191  
邮编(P.C): 201619



**EONGE 永锦电气**  
专注电力 服务全球  
FOCUS ON POWER · SERVE THE WORLD

# CONTENTS

## 产品目录

企业介绍 ..... P01-P02  
Company Introduction

### 一、智能电缆附件(高压电缆运行状态检测及安全预警系统) Intelligent Cable Accessories (HV Cable Operation Status Monitoring and Safety Early Warning System)

1. 智能电缆附件综合监控系统 HV Cable Intelligent Integrated Monitoring System ..... P03-P06
2. 电缆运行状态监测管控平台 HV Cable Operation Status Monitoring and Management System Platform ..... P07-P08
3. 内置式电缆接头导体测温系统 Built-in Cable Joint Conductor Temperature Measurement Systems ..... P09
4. 分布式光纤测温系统 Distributed Optical Fiber Temperature Measurement System ..... P10-P11
5. 内置式电缆局部放电监测系统 Built-in Cable Partial Discharge Monitoring System ..... P12-P13
6. 外置式电缆局部放电监测系统 External Cable Partial Discharge Monitoring System ..... P14-P15
7. 电缆终端头无源测温系统 Cable Termination Passive Temperature Measurement System ..... P16
8. 电缆终端头油位监测系统 Cable Termination Oil Level Monitoring System ..... P17
9. 电缆铅封状态监测系统 Cable Lead Seal Status Monitoring System ..... P18
10. 高压电缆故障精确定位预警系统 HV Cable Fault Precise Location and Early Warning System ..... P19-P20
11. 电缆防外力破坏预警系统 Cable External Damage Prevention and Early Warning System ..... P21-P22
12. 免维护无线环流监测系统 Maintenance-free Wireless Circulating Current Monitoring System ..... P23
13. 综合智能接地箱 Comprehensive Intelligent Earthing Box ..... P24

### 二、66-500kV高压电力电缆附件 66-500kV HV Cable Accessories

1. 高压交联电力电缆附件产品技术特点 Technical Features of HV XLPE Power Cable Accessories ..... P25-P26
2. 66-500kV交联聚乙烯绝缘电力电缆用复合套管/瓷套管终端 ..... P27-P28  
Composite Bushing/Ceramic Bushing Terminations for 66-500kV XLPE Insulated Power Cables
3. 66-500kV交联聚乙烯绝缘电力电缆用干式绝缘(变压器)GIS插入式/插拔式终端 ..... P29-P30  
Dry Insulation GIS (Transformer) Assembled/Plug-in Terminations for 66-500kV XLPE Insulated Power Cables
4. 66-500kV交联聚乙烯绝缘电力电缆用整体预制硅橡胶中间接头 ..... P31-P32  
Integrally Pre-molded Silicone Rubber Joints for 66-500kV XLPE Insulated Power Cables
5. 66-138kV交联聚乙烯绝缘电力电缆用整体预制干式绝缘户外终端 ..... P33  
Integrally Pre-molded Dry Insulation Outdoor Terminations for 66-138kV XLPE Insulated Power Cables
6. 66-110kV交联聚乙烯绝缘电力电缆用分支接头 ..... P34  
T-junctions for 66-110kV XLPE Insulated Power Cables

### 三、1-35kV中低压电力电缆附件 1-35kV Cable Accessories

1. 冷缩电缆附件技术特点 Technical Features of Cold-shrink Cable Accessories ..... P35-P36
2. 1-35kV冷缩式电缆附件 1~35kV Cold-shrink Cable Terminations ..... P37-P40
3. 10~35kV预制式电缆附件 10~35kV Pre-molded Cable Accessories ..... P41-P42
4. 10~35kV热缩式电缆附件 10~35kV Heat-shrink Cable Accessories ..... P43-P44
5. 10~110kV放热熔接式电缆中间接头 10~110kV Exothermic Welding Cable Joints ..... P45-P46
6. 10~35kV可分离连接器(设备终端) 10~35kV Separable Connectors (Equipment Terminations) ..... P47-P50

### 四、电缆附件附属设备 Auxiliary Equipment for Cable Accessories

1. 美式、欧式电缆分支箱 American-style and European-style Cable Branch Boxes ..... P47-P50
2. 35-220kV电缆接地箱 35-220kV Cable Earthing Boxes ..... P53-P54
3. 10-220kV中间接头防水、防爆壳 10-220kV Joint Waterproof and Explosion-proof Enclosures ..... P55-P56
4. FJA系列1kV树脂浇注电缆接头 FJA Series 1 kV Resin Cast Cable Joints ..... P57

### 五、高压电缆线路故障快速抢修接头 HV Cable Fault Emergency Repair Joints

### 六、铁路、风用电缆附件 Cable Accessories for Railway and Wind Power Applications

### 七、电缆管封堵器 Cable Pipe Sealers

### 八、自固化绝缘防水保护材料 Self-curing Insulating and Waterproof Protective Materials.

### 九、工程案例 Engineering Case

EONGGE

## 公司简介 COMPANY INTRODUCTION

自1988年创立,永锦电气始终以“助力电网高效安全运行”为使命,深耕高端电气装备领域。作为国家火炬计划重点单位、国家绿色供应链示范企业,凭借国家级高新技术企业的硬核实力,成为国家电网、南方电网核心战略合作伙伴。

Shanghai Yongjin Electric Technology Co., Ltd. was founded in 1988, and has always taken "Facilitating the efficient and safe operation of power grids" as its mission, while deeply focusing on the high-end electrical equipment field. As a key unit of the National Torch Program and a demonstration enterprise of the National Green Supply Chain, relying on the solid strength of a national high-tech enterprise, it has become a core strategic partner of State Grid Corporation of China (SGCC) and China Southern Power Grid (CSG).

永锦电气构建“院士工作站&研究院+双省级研发/技术中心”创新矩阵,依托上海、台州、嘉兴三大智慧生产基地,形成“研发-智造-服务”全产业链结构;产品覆盖高低压电力电容器、1~500kV中高压电缆附件等核心领域,业务遍布全国及海外市场。

Yongjin Electric has established an innovation matrix comprising "Academician Workstations & Research Institutes, as well as two provincial-level R&D and Technology Centers". Leveraging its three smart production bases in Shanghai, Taizhou and Jiaxing, the company has built a complete industrial chain integrating "R&D - Intelligent Manufacturing - Services". Its product portfolio covers core sectors including high and low voltage power capacitors and medium to high voltage cable accessories (1~500kV), with business operations spanning across domestic and overseas markets.

永锦电气深度参与国家重点工程建设,为酒泉卫星发射基地、北京奥运会、上海世博会、杭州G20峰会、北京大兴机场、白鹤滩特高压输电等标志性工程项目提供了优质产品,以“全生命周期保障体系”为电力安全保驾护航。

Yongjin Electric has played an active and pivotal role in the construction of national key projects, delivering high-quality, reliable products to numerous iconic landmark projects such as the Jiuquan Satellite Launch Center, the 2008 Beijing Olympic Games, the 2010 Shanghai World Expo, the G20 Hangzhou Summit, the Beijing Daxing International Airport, and the Baihetan UHV Power Transmission Project. It safeguards power system security through its proprietary "Full Life Cycle Support System".

展望未来,永锦电气将加速智能电网与低碳技术高效融合,致力成为电气制造与服务领域的头部企业。  
Looking ahead, Yongjin Electric will continue to explore innovative approaches to integrating smart grids and low-carbon technologies. Guided by its vision to become a leading player in the niche sector, the company is committed to driving the high-quality development of the industry.

## 企业愿景 Corporate Vision :

成为细分领域的头部企业。

To be a top enterprise in the niche segment.

## 企业理念 Corporate Philosophy :

助力电网高效、安全、可靠运行。

To facilitate the efficient, safe and reliable operation of power grids.

## 企业价值观 Corporate Value :

客户第一,拥抱创新。团结、协作、诚信、友善、学习、进取。

Customer First, Embrace Innovation Unity, Collaboration, Integrity, Amity, Learning, Progress.

## 重大业绩 Corporate Resources

- 酒泉卫星发射基地  
Jiuquan Satellite Launch Center
- 北京奥运会  
Beijing Olympic Games
- 上海世博会  
Shanghai World Expo
- 杭州G20峰会  
G20 Hangzhou Summit
- 北京大兴机场  
Beijing Daxing International Airport
- 特高压直流输电雅中-南昌、白鹤滩-江苏、白鹤滩-浙江、陇东-山东、哈密-重庆、陕北-安徽等标志性工程  
Landmark UHVDC (Ultra-High Voltage Direct Current) transmission projects including Yazhong-Nanchang, Baihetan-Jiangsu, Baihetan-Zhejiang, Longdong-Shandong, Hami-Chongqing and Shanbei-Anhui projects

## 企业资源 Corporate Resources

- ① 公司核心团队由行业内知名专家、学者构成;  
The core team is composed of well-known experts and scholars in the industry.
- ② 公司主要生产设备购置美国、德国、日本、瑞士等国家及地区;  
The main production equipment is procured from the United States, Germany, Japan, Switzerland and etc.
- ③ 公司是电力电容器、电缆附件国家标准、行业标准的编制、修订的成员单位;  
Eonge is a participating member in the formulation and revision of national and industrial standards for power capacitors and cable accessories.
- ④ 公司与国网电力科学研究院武汉分院、西安高压电器研究院、上海电缆研究所、上海电力公司松江供电公司、浙江大学等产学研单位建立了密切的科技协作关系;  
Eonge has established close scientific and technological cooperation ties with industry-university-research institutions including Wuhan Branch of State Grid Electric Power Research Institute, Xi'an High Voltage Apparatus Research Institute, Shanghai Cable Research Institute, Songjiang Power Supply Company of Shanghai Electric Power Company, and Zhejiang University.
- ⑤ 公司现有上海、台州、嘉兴三大制造基地,拥有超600余名的员工和60余项的产品资质和专利  
Eonge operates three major manufacturing bases in Shanghai, Taizhou and Jiaxing, with a workforce of over 600 employees, as well as more than 60 product certifications and patents

## 企业资质

重大业绩 Major Achievements	省市级企业技术中心 Provincial and Municipal-level Enterprise Technology Center
国家级高新技术企业 National High-Tech Enterprise	省市级企业研发中心 Provincial and Municipal-level Enterprise R&D Center
国家级绿色供应链示范企业 National-level Green Supply Chain Demonstration Enterprise	院士专家工作站 Academician and Expert Workstation
国家级绿色工厂 National and Municipal-level Green Factory	省市级重点专精特新企业 Provincial and Municipal-level Key Specialized, Sophisticated, Unique and Novel Enterprise



ISO 9001:2015质量管理体系认证  
ISO 9001:2015 Quality Management System Certification  
14001:2015环境管理体系认证ISO  
ISO 14001:2015 Environmental Management System Certification  
ISO 45001:2018职业健康安全管理体系认证  
ISO 45001:2018 Occupational Health and Safety Management System Certification

ISO 50001:2018能源管理体系认证  
ISO 50001:2018 Energy Management System Certification  
ISO 14067-2018 : 温室气体 产品碳足迹 量化要求和指南  
ISO 14067:2018 Greenhouse Gases – Carbon Footprint of Products – Requirements and Guidelines for Quantification



# 智能电缆附件系统

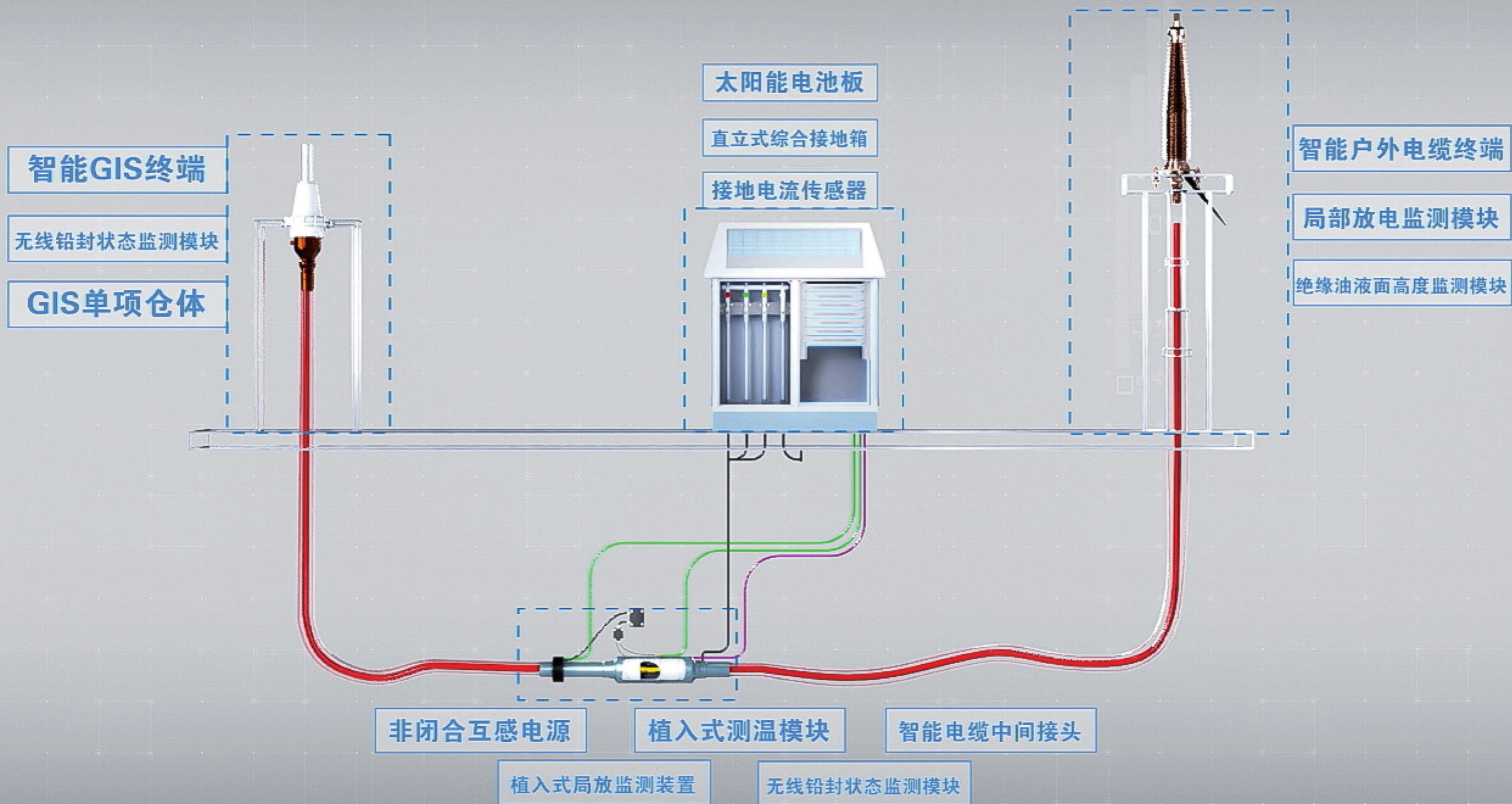

## 高压电缆智能综合监控系统 HV Cable Intelligent Integrated Monitoring System

### 系统概述

#### System Overview

智能电缆附件综合监控系统是综合先进的传感器采集技术,物联网通讯技术、计算机的大数据分析与人工智能算法技术相结合,对电力电缆的运行状态进行全天候、多维度的实时感知、智能评估与集约化管理,是构建“可视、可测、可控”智能配电网的重要组成部分,系统管理包含:电力电缆运行安全(测温、局放、环流、液位、铅封、故障定位、防外力破坏)、综合环境(有害气体、淹积水、温湿度、电源/照明、消防/烟雾)及安防监控(智能井盖、智能地钉、门禁、人员定位、远程广播、应急通信)等。

The HV Cable Intelligent Integrated Monitoring System combines advanced sensor acquisition technology, IoT communication technology, big data analysis, and artificial intelligence algorithms. It provides 24/7, multi-dimensional real-time perception, intelligent evaluation, and intensive management of power cable operation status. As a key component of building a "visible, measurable, and controllable" intelligent distribution network, the system covers: power cable operation safety (temperature measurement, partial discharge, circulating current, liquid level, lead seal, fault location, external damage prevention), comprehensive environment (harmful gases, waterlogging, temperature & humidity, power supply/lighting, fire protection/smoke), and security monitoring (intelligent manhole covers, intelligent ground nails, access control, personnel positioning, remote broadcasting, emergency communication).

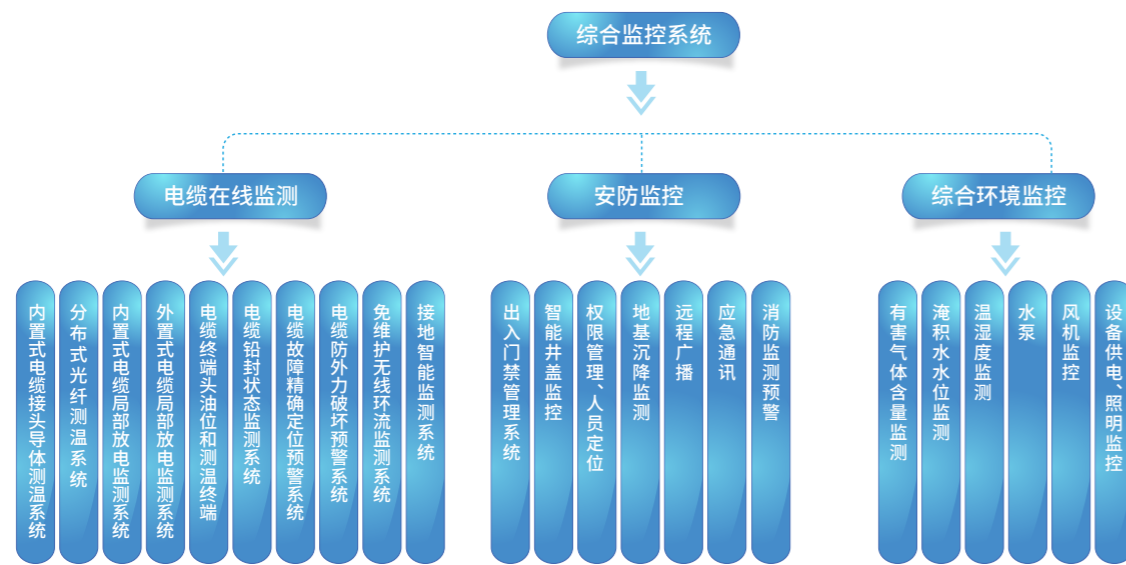

综合系统框架图  
Comprehensive System Framework Diagram

### 系统功能

#### System Functions

#### ① 电缆设备运行参数监测 Cable Equipment Operation Parameter Monitoring:

- 电缆导体温度监测 Cable conductor temperature monitoring
- 电缆局部放电监测 Cable partial discharge monitoring
- 电缆终端头油位监测 Cable termination oil level monitoring
- 电缆铅封状态监测 Cable lead seal status monitoring
- 电缆故障精准定位 Precise cable fault location
- 电缆防外力破坏预警 Cable external damage prevention and early warning
- 护层环流电压监测 Sheath circulating current and voltage monitoring
- 智能接地箱 Intelligent earthing box

#### ② 综合环境监控 Comprehensive Environment Monitoring:

- 有害气体检测(一氧化碳、硫化氢、甲烷及含氧量等)、风机联动控制、水位监测及水泵联动控制。  
Harmful gas detection (carbon monoxide, hydrogen sulfide, methane, oxygen content, etc.), fan linkage control, water level monitoring, and water pump linkage control.
- 环境参数监测:温度、湿度、气压、风速、降雨量等  
Environmental parameter monitoring: temperature, humidity, air pressure, wind speed, rainfall, etc.
- 超限报警,可(手动/自动)远程控制(风机/水泵),在监控平台闪烁显示,并可通过语音、短信方式自动快速通知值班人员。  
Overlimit alarm, with remote control (manual/automatic) of fans/water pumps, flashing display on the monitoring platform, and automatic quick notification to on-duty personnel via voice and SMS.
- 管廊、隧道环境温湿度监测  
Temperature and humidity monitoring in utility tunnels and pipelines.
- 供电电源及照明控制  
Power supply and lighting control.

#### ③ 安防监控 Security Monitoring:

- 远程门禁、智能井盖开启,出入口安装电控门禁/智能井盖,可视频联动。  
Remote access control and intelligent manhole cover opening, electric access control/intelligent manhole covers installed at entrances and exits with video linkage.
- 非法入侵报警,并可通过语音、短信方式自动通知值班人员。  
Illegal intrusion alarm with automatic notification to on-duty personnel via voice and SMS.
- 权限管理、人员定位、实施掌握进入人员位置,智能管理、保障人员安全。  
Authority management and personnel positioning to real-time track the location of entry personnel, enabling intelligent management and ensuring personnel safety.
- 应急指挥调度监控、设置公共广播,紧急情况下通知人员疏散。  
Emergency command and dispatch monitoring with public broadcasting to notify personnel evacuation in emergencies.
- 建设通讯、监控系统,设置定点无线基站,实现与监控中心应急通信。  
Construction of communication and monitoring systems with fixed wireless base stations to achieve emergency communication with the monitoring center.
- 监测地基沉降、河道涨潮等情况。  
Monitoring of foundation settlement, river tide, and other conditions.

### 电力电缆在线监测系统架构图

#### System Overview

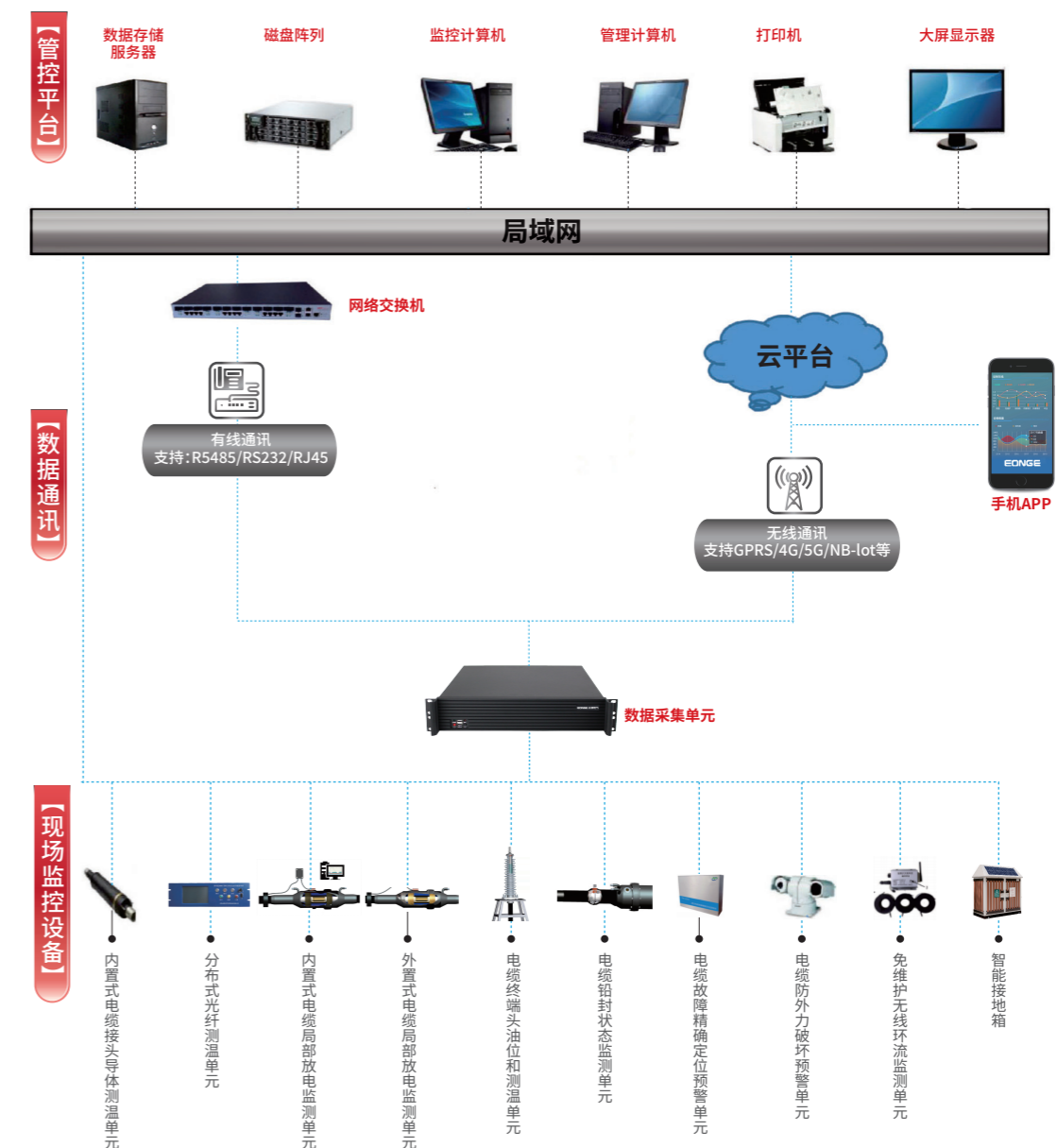

高压电缆运行状态监测管理系统平台  
HV Cable Operation Status Monitoring and Management System Platform

系统平台简介 System Platform Introduction

高压电缆运行状态监测及安全预警系统软件,即实时数据监测管理平台,可接入电缆导体温度监测、电缆局部放电监测、电缆终端头油位监测、电缆铅封状态监测、电缆故障精确定位、电缆防外力破坏预警、互层环流电压监测、智能接地箱、环境监测等数据,平台提供多样化组态,具备数据存储、智能告警、设备坐标定位、维护信息记录和查看、设备在线离线状态、设备台账管理等功能,具有“集成管理、分布式控制、全面监控、安全联动、监控组态”等众多特色。

The HV Cable Operation Status Monitoring and Safety Early Warning System software is a real-time data monitoring and management platform. It can access data such as cable conductor temperature monitoring, cable partial discharge monitoring, cable termination oil level monitoring, cable lead seal status monitoring, precise cable fault location, cable external damage prevention and early warning, inter-section circulating current & voltage monitoring, intelligent earthing box, and environmental monitoring. The platform offers diverse configurations and features data storage, intelligent alarm, equipment coordinate positioning, maintenance information recording and viewing, equipment online/offline status, and equipment account management. It boasts numerous advantages including "integrated management, distributed control, comprehensive monitoring, safety linkage, and monitoring configuration".



PC端软件 System Platform Introduction



移动APP软件 Mobile APP Software

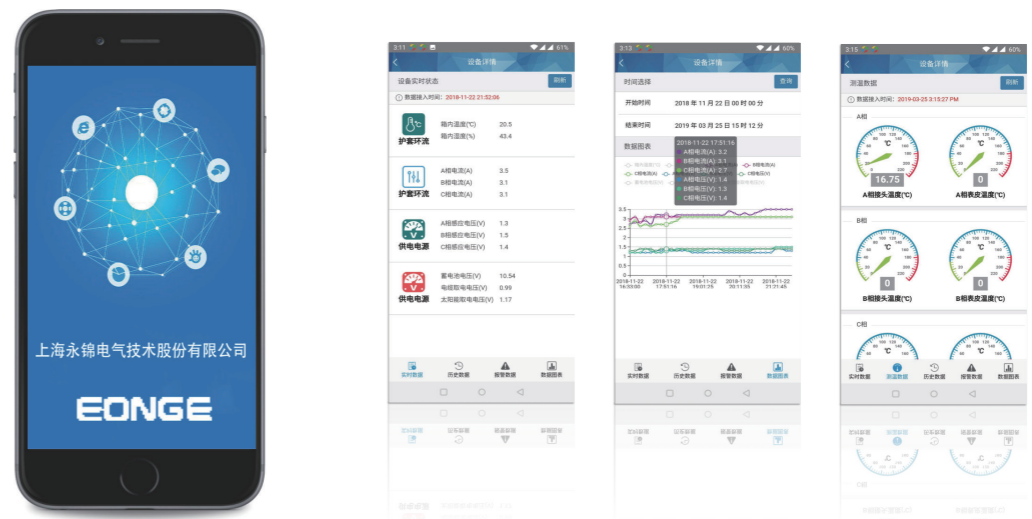

系统功能 System Platform Introduction

- 支持电脑PC端和移动APP数据查看  
Supports data viewing on PC and mobile APP
- 系统运行平稳可靠  
Stable and reliable system operation
- 支持数据、图表、曲线等多模式展示  
Supports multi-mode display of data, charts, curves, etc.
- 数据实时显示、设定阈值参数,数据超阈值报警  
Real-time data display, threshold parameter setting, and alarm for data exceeding threshold
- 数据查看、历史记录查看、数据打印/导出等功能  
Data viewing, historical record viewing, data printing/exporting, and other functions
- 根据监测数据,建立设备状态评估体系,以不同风险等级实时显示设备设备状态。  
Establishes an equipment status evaluation system based on monitoring data, displaying equipment status in real-time with different risk levels

内置式电缆接头导体测温系统  
Built-in Cable Joint Conductor Temperature Measurement System

产品简介 Product Introduction

主要用于35kV~500kV电压等级的电缆中间接头导体运行温度实时监测,通过110KV、220KV型式试验及中电联组织的新产品鉴定会。目前已在国家电网和南方电网多地示范应用。

For real-time temperature monitoring of the conductor temperature in 35 kV to 500 kV cable joints. Passed Type Tests for 110 kV and 220 kV, and obtained New Product Appraisal by the China Electricity Council (CEC). Successfully deployed in demonstration projects across the State Grid Corporation of China (SGCC) and China Southern Power Grid (CSG).

基本原理 Basic Principle

内置式电缆接头导体测温装置  
Built-in Temperature Monitoring Device for Cable Joint Conductors

基于电磁感应的非接触式测温原理,主要包括两部分:内置测温模块和外置测温中继。外置测温中继通过电磁耦合方式将能量和信号传递到电缆接头导体部位的内置测温模块,内置测温模块获得电能的同时将温度数据以无线的方式发送至外置测温中继,实现电缆导体温度的精准测量,不改变电缆接头物理结构和电气特性,具有安全免维护安装方便等优点。

Based on the non-contact electromagnetic induction principle, this device comprises two core components: a Built-in Sensing Module and an External Relay Unit. The External Relay Unit transmits power and signals to the Sensing Module (installed on the cable joint conductor) via electromagnetic coupling. Powered by this energy, the Sensing Module wirelessly sends real-time temperature data back to the Repeater Unit, enabling accurate conductor temperature measurement. Key Advantages: No modification to the cable joint's physical structure or electrical properties; Non-contact, safe, and maintenance-free; Easy installation.

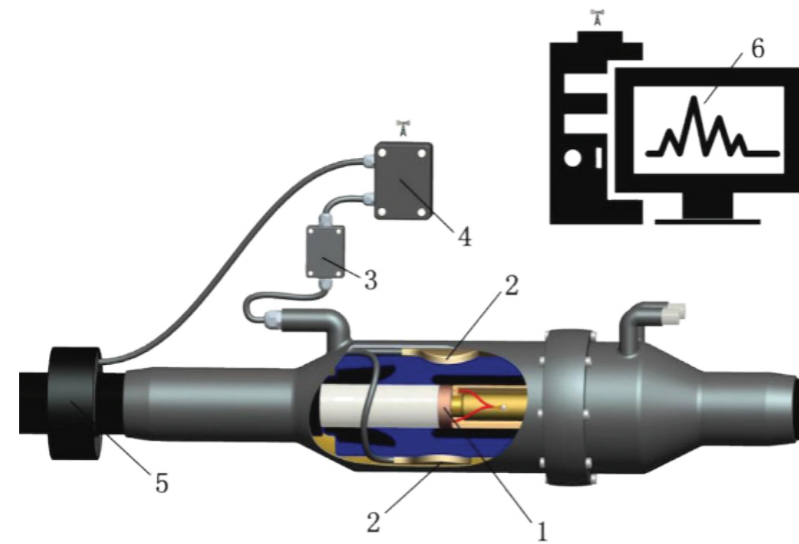

内置式电缆接头导体测温系统  
Built-in Cable Joint Conductor Temp Monitoring System

- |  |  |
|--|--|
| 1 内置测温模块<br>Built-in Temperature Monitoring Module | 4 电缆运行状态监测<br>Cable Operation Monitoring Cabinet         |
| 2 测温中间内置部分<br>Built-in Temperature Sensing Unit    | 5 非闭合互感电源<br>Split-core Current Transformer Power Supply |
| 3 测温中继外置部分<br>External Temperature Repeater Unit   | 6 电缆运行状态监测应用终端<br>Cable Operation Monitoring Terminal    |

系统技术参数:  
System Specifications:

适用性能 Applicable Performance	
测温精度Temp Measurement Accuracy	±0.5°C
工作电源Working Power Supply	在额定电压(15V) 20%内能正常工作 Can work normally within 20% of the rated voltage (15V)
整机功耗Overall Power Consumption	三项同时测温时约15W, 空闲时约2.5W Approximately 15W when measuring temperature of three phases simultaneously, and approximately 2.5W in standby mode
防护等级Protection Grade	IP67
工作环境温度Operating Ambient Temperature	无线测温模块: -40°C~ +85°C Wireless Temperature Measurement Module: -40°C~ +85°C
工作环境湿度Operating Ambient Humidity	10%~100%RH
大气压力Atmospheric Pressure	70KPa~106KPa
试验年限Test Service Life	≥30 years

分布式光纤测温系统  
Distributed Optical Fiber Temperature Measurement System

产品简介 Product Introduction

分布式光纤测温(电缆载流量评估)系统  
Distributed Fiber Optic Temperature Sensing (DTS) System with Dynamic Ampacity Calculation

基于DTS分布式光纤测温技术,利用光时域反射(OTDR)技术和拉曼(Raman)散射效应测量沿光纤分布的温度变化,可实时监测电缆表面温度。采用国际电工委员会标准IEC60287、IEC60853算法模型,结合实际电缆工况实时计算导体温度和动态载流量,为电缆安全运行监测和负荷管理提供有效帮助。

DTS (Distributed Temperature Sensing) technology, the system utilizes OTDR principles and the Raman scattering effect to measure temperature distributions along the optical fiber, enabling real-time monitoring of cable surface temperatures. Compliant with IEC 60287 and IEC 60853, the system integrates real-time operating conditions to calculate conductor temperatures and dynamic ampacity. It provides critical data support for cable load management and operational safety.

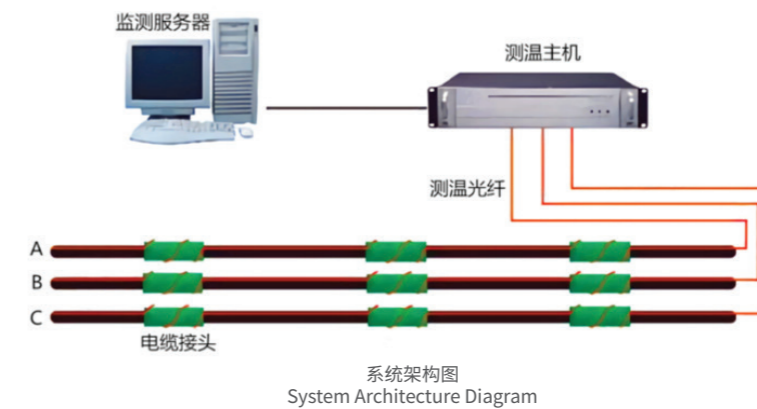

系统架构图  
System Architecture Diagram

产品实物

Product Photo



测温主机 Main Temperature Monitoring Unit

系统技术参数:  
System Specifications:

测温性能 Temp Measurement Performance	
测温距离 Temp Measurement Distance	0~16Km
测量时间 Measurement Time	2s~10s/通道Channel
测温精度 Temp Measurement Accuracy	±0.5°C、±1°C、±2°C (全范围 Full Range)
温度分辨率 Temp Resolution	0.1°C
通道数量 Number of Channels	1~8 (可选Optional)
测量范围 Measurement Range	-40°C~85°C (常规光纤 Regular Optical Fiber) -40°C~250°C (特殊光纤 Special Optical Fiber)
采样间隔 Sampling Interval	0.4m、0.8m、1m
空间分辨率 Spatial Resolution	1m、2m、3m
定位精度 Positioning Accuracy	1m
系统接口 System Interface	
光纤接头Optical Fiber Connector	FC/APC
通讯接口Communication Interface	RJ45、USB、RS232
继电器Relay	46路温度报警、2路系统报警 46-channel temperature alarm, 2-channel system alarm
工作性能 Working Performance	
工作温度 Operating Temp	-10°C~60°C
工作湿度 Operation Humidity	0~95%RH无凝露No Condensation
工作电源 Working Power Supply	DC24V、AC220V (可选Optional)
IP等级 IP Rating	IP50

技术特点

Technical Features

- 温度实时监测 Real-time Temperature Monitoring**  
 根据电缆表面温度和负荷电流数据,实时计算电缆径向温度分布,可对电缆导体温度进行暂态计算。  
 Based on cable surface temperature and load current data, the system calculates the cable's radial temperature distribution in real-time and performs transient calculations of the conductor temperature.
- 温度异常报警 Abnormal Temperature Alarm**  
 可设置预警阈值参数,具备超温报警、温升速率报警、区域温差报警等功能,并能显示、记录温度数据和报警位置。  
 Configurable temperature thresholds enable multi-level alarm functions, including overtemperature, excessive temperature rise rate, and inter zone temperature difference alarms. The system displays and logs temperature data with precise alarm location.
- 动态载流量分析 Dynamic Ampacity Analysis**  
 根据导体温度及实时负荷电流数据,预测最大运行电流或预设电流的电缆安全运行时间;支持电缆隧道、排管、沟道、桥架、直埋和充沙等不同应用环境。  
 Based on conductor temperature and real-time load current data, the system predicts the maximum operating current and the safe remaining service time at a preset current. It supports all standard cable installation scenarios, including tunnels, ducts, trenches, cable trays, direct burial, and sand-filled bedding.
- 紧急状态预测 Emergency State Prediction**  
 预设过载电流和过载时间,可计算电缆的过载温度;预设过载电流和最大允许温度,可计算过载时间;预设过载时间和最大允许温度,可计算最大允许过载电流。  
 Calculates overload temperature based on preset overload current and duration. Determines permissible overload duration from preset current and maximum allowable temperature. Computes maximum allowable overload current using preset duration and temperature limits.

内置式电缆局部放电监测系统  
Built-in Cable Partial Discharge Monitoring System

产品简介

Product Introduction

产品在接头应力锥两端安装6个内置局放传感器,多角度矩阵式检测,抗干扰能力强,实现快速准确测量局放目的。已完成220KV型式试验,并取得中国电科院武汉分院和上海电缆研究所局放精度对比试验报告及内置式电缆测温、局放一体式智能型接头型式试验报告。

Equipped with six built-in PD sensors arranged in a multi-angle matrix at both ends of the joint stress cone, the product delivers high anti-interference capability for fast and accurate PD measurement. Successfully passed the 220 kV Type Test. Validated by PD accuracy comparison reports from the Wuhan Branch of China Electric Power Research Institute (CEPRI) and the Shanghai Cable Research Institute (SCRI), as well as the Type Test Report for the Integrated Intelligent Joint with built-in temperature and PD monitoring functions.

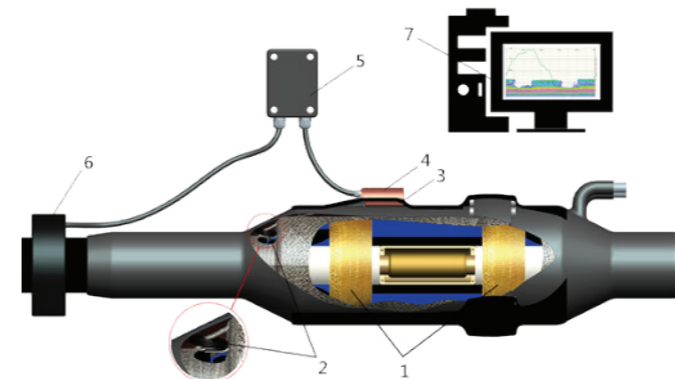

- 内置容式局放传感器  
Built-in PD Sensor (Capacitive Type)
- 内置感式局放传感器  
Built-in PD Sensor (Inductive Type)
- 内置局放采集模块  
Built-in PD Acquisition Module
- 外置局放采集中继  
External PD Acquisition Repeater
- 局放监测系统主机  
PD Monitoring System Main Unit
- 非闭合互感电源  
Split-core CT Power Supply
- 局放监测专家库软件  
PD Monitoring Expert Library Software

功能特点

Function Features

● 抗干扰能力强 Strong Anti-Interference Capability

通过内置局放传感器在接头应力锥两端, 具有极强的电磁兼容性和抗干扰能力, 实现强干扰环境下局部放电的准确在线监测。  
Built-in PD sensors at both ends of the joint stress cone ensure excellent EMC performance, enabling accurate online PD monitoring even in high-interference environments.

● 监测数据准确 Accurate Monitoring Data

通过矩阵和差分算法, 实现局放的精准测量。  
Matrix and differential algorithms ensure precise PD measurement.

● 数据应用 Data Application

局放基础数据保存至数据库内, 便于对接头建立局放分析库, 实现接头绝缘故障预判。  
Basic PD data is stored in the database to establish a PD analysis library for joints, enabling early prediction of insulation faults.

● 数据分析 Data Analysis

通过局放幅值和相位关联对比分析, 消除干扰信号, 实现精确数据数据分析, 对同一监测点数据趋势分析, 报警时间记录。  
PD amplitude-phase correlation analysis filters out interference signals for precise data interpretation. It supports trend analysis of historical data at each monitoring point and provides detailed alarm logging.

系统技术参数:

System Specifications:

通用性能 General Performance	
局放测量精度PD Measurement Accuracy	±5pC
局放测量频带PD Measurement Bandwidth	80kHz~20MHZ
局放测量范围PD Measurement Measurement Range	2pC~500pC
防护等级Protection Grade	IP68
通讯方式Communication Method	无线通讯/有线通讯Wireless Communication/Wired Communication
工作电压Working Voltage	DC12V
功耗Power Consumption	<2.5w

应用软件

Application Software



外置式电缆局部放电监测系统  
External Cable Partial Discharge (PD) Monitoring System

产品简介

Product Introduction

电缆局部放电监测系统通过在电缆附件外部安装局部放电监测设备, 实时监测电缆系统内部发生的局部放电信号。  
The Cable PD Monitoring System deploys monitoring devices externally on cable accessories to monitor internal PD signals in real time.

电缆局放监测技术前端传感部分采用高频脉冲电流传感局放检测技术, 具有检测灵敏度高、抗干扰能力强、定位准确、安装适配性强的特点。通过局放分析模块和专家库的建设应用, 对原始数据分析计算后直接给出量化结果, 定位局放位置, 可以检测放电量, 次数, 相位等参数, 可以回放局放演变趋势, 用户可以随时掌握电缆附件内部局放量的大小数和变化趋势, 有效评估电缆运行安全性, 提前发现运行缺陷, 提高线缆安全性。

Utilizing High-Frequency Current Transformer (HFCT) technology, the front-end sensors offer high detection sensitivity, superior anti-interference capability, accurate positioning, and flexible installation. Equipped with a PD Analysis Module and Expert Library, the system processes raw data to generate quantitative results, including discharge magnitude, repetition rate, and phase, along with historical trend playback. This allows users to continuously track PD activity inside cable accessories, effectively evaluate operational safety, detect defects early, and enhance overall cable reliability.

局部放电信号通过光缆(或无线发射装置)传输到监控中心, 并通过分析系统对局部放电的类型和局部放电水平进行分析判断, 评估局部放电的影响, 判断设备绝缘状态, 并给出相应设备维护维修指导方案。

PD signals are transmitted to the monitoring center via optical cable or wireless devices. The analysis system evaluates PD types and severity to assess insulation conditions and potential risks, providing specific maintenance guidelines for optimal asset management.

技术特点

Technical Features

● 系统主要包括 System Components:

电缆局放监测专家库软件、局放监测主机、通讯网络、局放采集器、局放传感器等;  
PD Monitoring Expert Software, PD Main Unit, Communication Network, PD Acquisition Unit, and PD Sensors.

● 系统采用频带在高频波段, 现场抗干扰能力强;

High-Frequency Band Operation: Delivers superior anti-interference performance in harsh field environments.

● 外置式设计, 可适用于存量电缆系统, 可后期加装或改装;

External Retrofit Design: Ideal for existing cable systems, enabling easy on-site installation or upgrade.

● 传感器采用开合式钳形传感器, 便捷安装;

Split-Core Clamp-On Sensors: Facilitate fast, tool-free, and non-intrusive installation.

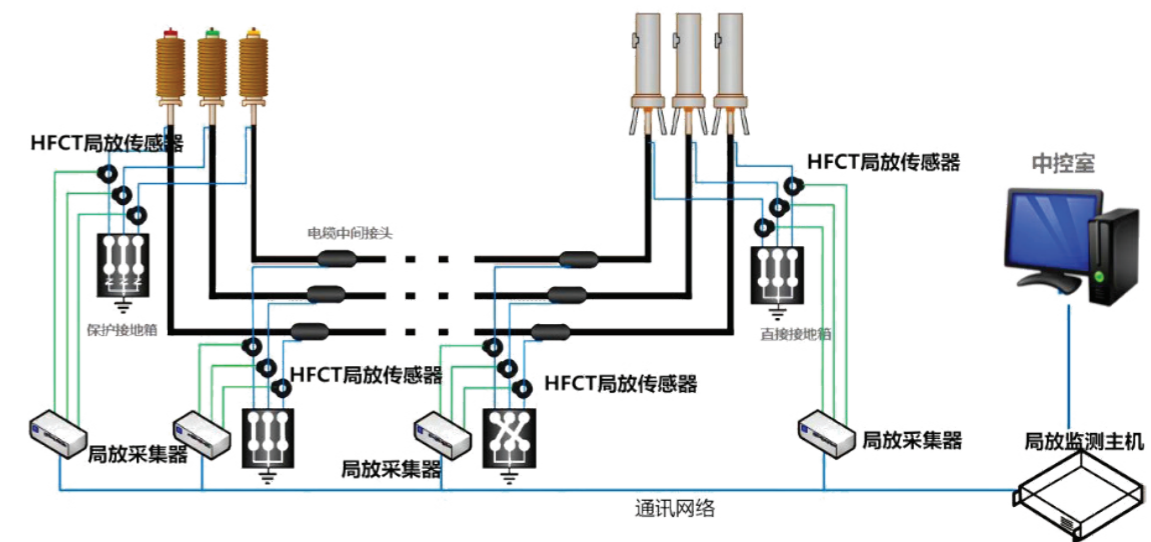

外置式电缆局放监测系统示意图  
Schematic Diagram of External Cable PD Monitoring System

一体化监测装置 Integrated Monitoring Device

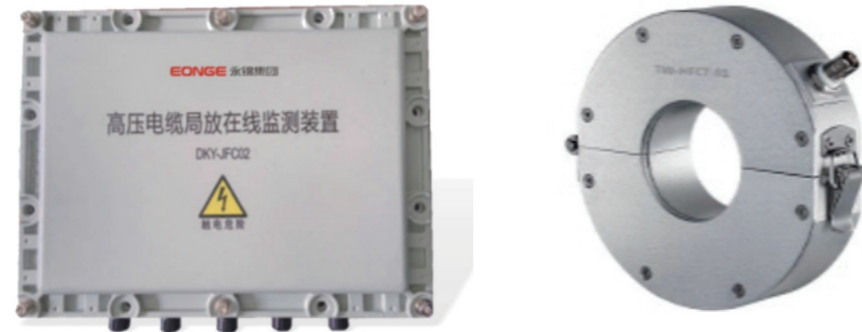

技术参数  
Technical Specifications

通用性能 General Performance	
Pd通道数 Number of Channels	3
频率范围 Frequency Range	10kHz~30MHz
采用频率 Frequency Agile	100Mps
测量范围 Measurement Range	5pC~5000pC

主要功能 Key Features

- 可读取所采集的数据,实时显示整个系统的任意数据,并可根据用户的设定需求显示平均值、最大值等;  
Retrieves collected data, displays any system data in real-time, and presents key metrics (e.g., average value, maximum value) per user-configured preferences.
- 专业图谱分析功能 Professional graph analysis:  
具有局放幅值积累图、局放数据显示、单周期图数据显示、短期趋势显示图以及二维、三维图谱等,并能完成数据横向对比、不同图标之间的叠加对比功能;  
Features PD amplitude accumulation graphs, PD data display, single-cycle data graphs, short-term trend graphs, as well as 2D and 3D spectra; enables horizontal data comparison and overlay comparison between different graphs.
- 通过精确的分析软件对局放幅值和相位关联的对比分析,消除干扰信号,实现对同一监测点的精确数据分析,形成报警事件记录。  
Eliminates interference signals via specialized analysis software through precise correlation analysis of PD amplitude and phase, enabling accurate data analysis for the same monitoring point and generating alarm event records.
- 通过提取局部放电信号的特征值,如时间特征、频率特征、及不同类型放电间的放电时间间隔等。并利用这些特征来识别不同的放电类型。  
Extracts characteristic values of PD signals, such as temporal features, frequency features, and discharge time intervals between different discharge types, and uses these characteristics to identify various discharge categories.
- 系统采用模块化结构,具备较强的扩展功能,可以根据线路及用户需求对系统进行扩容。  
Adopts a modular structure with robust expandability, allowing system capacity expansion based on line requirements and user needs.

电缆终端头无源测温系统  
Passive Temperature Monitoring System for Cable Terminals

产品简介 Product Introduction

此装置由无线无源测温模块、通讯主机(中继设备)、显示终端、后台中心软件四个部分组成,采用感应取电、无线传输、直接接触导体测量温度;适用于开关、母排及终端头等高压电气连接点的温度监测,实现温度薄弱环节实时监测、显示、预警、报警等功能。

Composed of four components—wireless passive temperature measurement module, communication host (relay device), display terminal, and backend software—it adopts inductive power harvesting, wireless transmission, and direct conductor contact for temperature measurement. Suitable for temperature monitoring of high-voltage electrical connection points such as switches, busbars, and terminals, it achieves real-time monitoring, display, early warning, and alarm functions for temperature-sensitive areas.

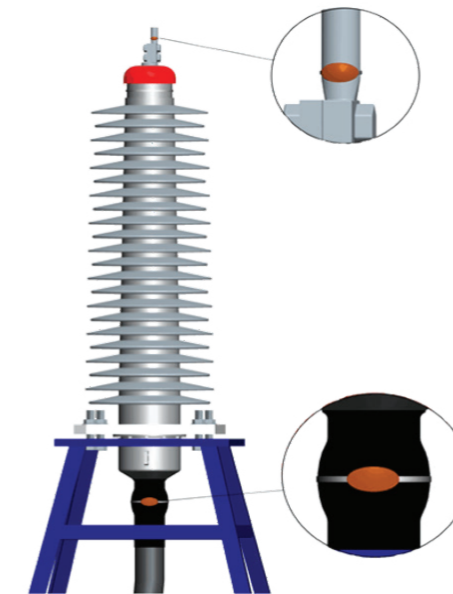

通用性能 General Performance	
测量精度 Measurement Accuracy	±1.0°C
测量距离 Measurement Distance	传输100米 Transmit Range: 100m
防护等级 Protection Level	IP68
电源方式 Power Supply Method	感应取电 Inductive Power Harvesting
启动电流 Starting Current	一次电流 Primary Current 5A



无线测温模块  
Wireless Temp Measurement Module

## 电缆终端头油位监测系统 Oil Level Monitoring System for Cable Terminals

### 产品简介

#### Product Introduction

终端头油位监测系统使用超声波对封油高度进行检测。超声波在液体、固体中的衰减很小,因而穿透能力强,尤其是在对光不透明的固体中,超声波可穿透几十米的长度,碰到杂质或界面就会有显著的反射。利用这一特性可计算封油的高度。

Ultrasonic technology is adopted for sealing oil level detection in this terminal head oil level monitoring system. Ultrasonic waves feature minimal attenuation in liquids and solids, granting strong penetration capability. Especially in light-opaque solids, they can travel dozens of meters and produce significant reflections upon contact with impurities or interfaces. This characteristic is utilized to calculate the sealing oil level.

系统使用取电技术对设备进行供电,利用无线信号传输技术进行数据传输,不改变任何施工环境的条件下完成对信号的采集和传输。

Powered by energy harvesting technology with data transmission via wireless signal technology, it enables signal acquisition and transmission without altering the existing installation conditions.

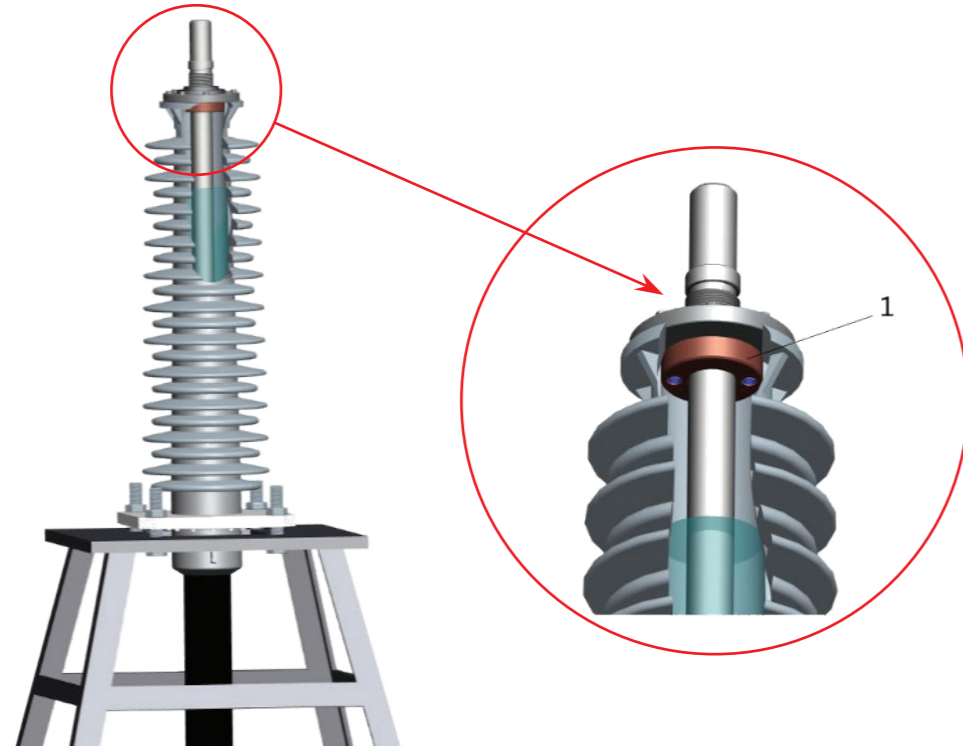

#### 系统技术参数:

System Specifications:

通用性能 General Performance	
测量精度 Measurement Accuracy	0.5级 Grade 0.5
工作电源 Working Power Supply	CT取电 CT Power Harvesting, AC220V, 太阳能 Solar Energy
数据传输方式 Data Transmission Method	GPRS, 4G, 短信 SMS, 无线点对点传输 Point-to-Point Wireless Transmission, 光纤 Optical Fiber
工作电流 Operating Current	最小 Min :3mA, 最大 Max :120mA
工作环境温度 Operating Ambient Temp	-55°C~85°C
运行环境温度 Operating Humidity	15%~98%RH
大气压力 Atmospheric Pressure	86~106KPa

## 电缆铅封状态监测系统 Cable Seal Monitoring System

### 产品简介

#### Product Introduction

电缆铅封监测系统主要由内置电阻传感器、外置采集中继及监测软件组成,系统采用电阻法监测电缆接头两端的铅封状态,将内置电阻传感器安装在铅封层表面,测量两点之间区域阻值,适用于35kV及以上电缆中间接头和电缆终端头铅封状态监测。

The system comprises built-in resistance sensors, external acquisition repeaters, and monitoring software. Utilizing a resistance-based method, it monitors the seal integrity at both ends of cable joints. By measuring the inter-electrode resistance via surface-mounted sensors, the system is ideally suited for monitoring the seal condition of 35kV and above cable splices and terminations.

### 结构简图

#### Structure Diagram

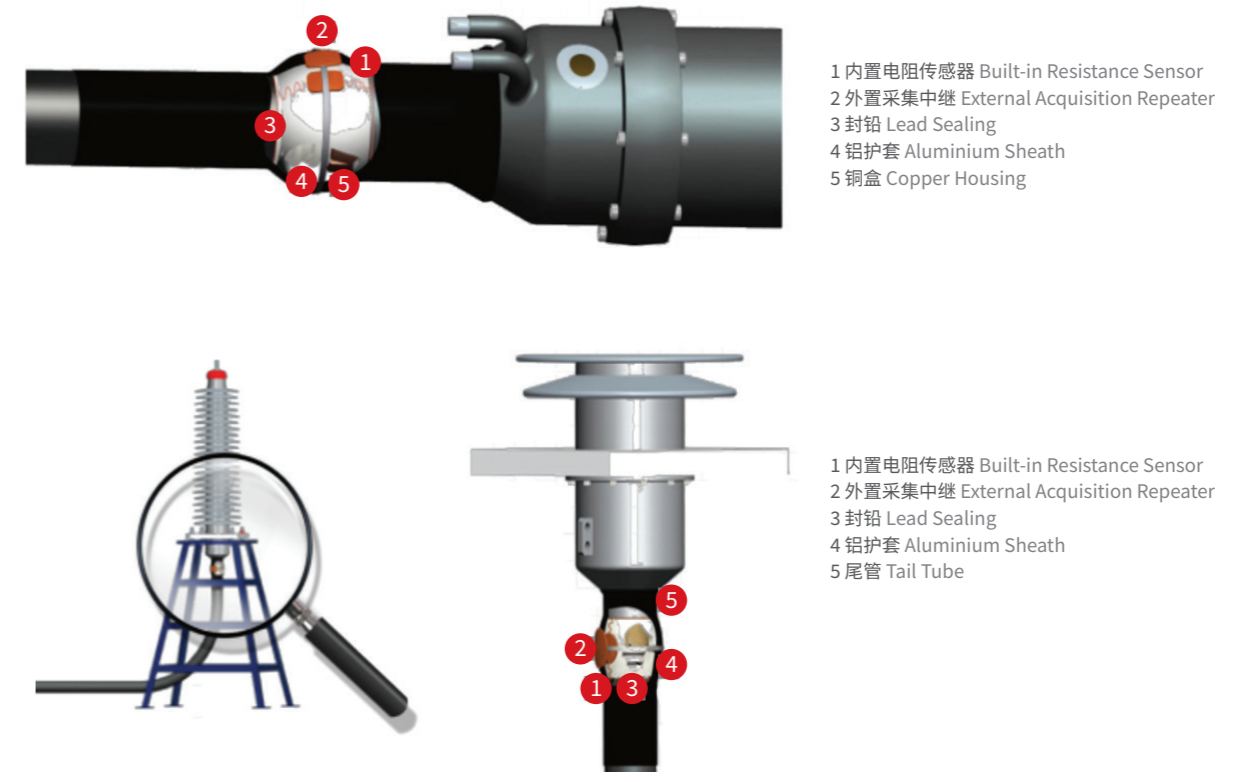

#### 系统技术参数:

System Specifications:

通用性能 General Performance	
工作电压 Operating Voltage	DC12V
工作功耗 Operating Power	≤2w
测量电阻范围 Resistance Measurement Range	0~102Ω
测量精度 Measurement Accuracy	1mΩ

#### 主要功能

Key Features

对铅封状态实时监测 Real-time monitoring of seal integrity  
铅封脱落的监测 Detection of seal detachment  
铅封裂变监测 Detection of seal cracking  
趋势分析、智能判断 Trend analysis and intelligent diagnosis

## 高压电缆故障精确定位预警系统 HV Cable Fault Location and Early Warning System

### 产品简介

### Product Introduction

高压电缆故障精确定位预警系统广泛应用于35KV~500KV电压等级电缆线路故障精确定位与故障识别。系统为分布式结构,基于电流、行波、局放同时采样,北斗高精度和电缆铠装同步授时,高精度晶振加密算法和信号相位误差精确校准等。先进技术的应用:并采用时间差测量(双端测量)法和条线关联试图的故障预警模式,可辅助电缆运检人员提前发现电缆故障,并自动、快速定位。

This system is widely applied for fault location and identification on cable lines rated from 35kV to 500kV. Featuring a distributed architecture, it integrates simultaneous sampling of current, traveling waves, and PD signals. Its high precision is enabled by BDS high-accuracy time synchronization (including cable armor synchronization), high-stability crystal oscillator-based encryption algorithms, and precise calibration of signal phase errors. Utilizing the time difference method (two-terminal measurement) and a line correlation view for fault early warning, the system empowers maintenance crews to detect potential faults proactively and achieve automatic, rapid fault localization.

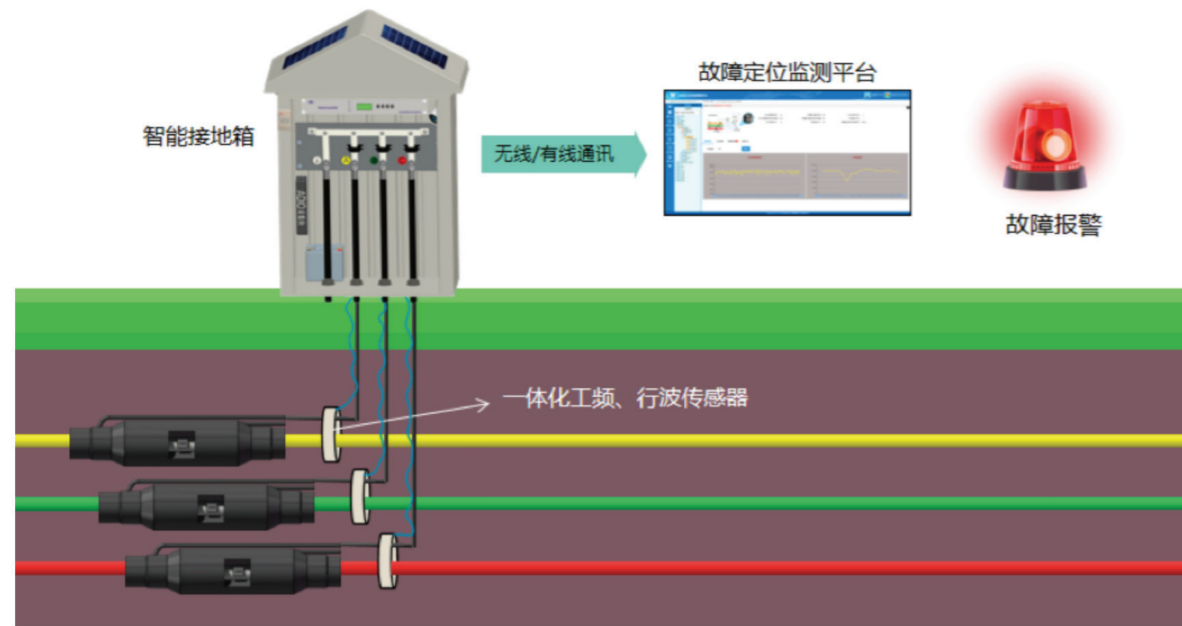

### 系统功能

### System Features

- **故障智能预警 Intelligent Fault Early Warning**  
采用工频电流、行波、局放同时采样,对电缆运行状态进行全过程趋势分析,故障前期发现缺陷信号。  
Monitors power frequency current, traveling waves, and PD simultaneously. Performs comprehensive trend analysis to detect incipient fault signals and provide early warning.
- **故障精确定位 Precision Fault Location**  
实现电缆线路的故障精确定位,分布式区间定位准确率≥99%,故障定位误差≤10m。  
Enables accurate fault pinpointing for cable lines. Distributed section location accuracy: ≥99%, Fault location error: ≤10 m
- **故障原因 Faulty Cause Analysis**

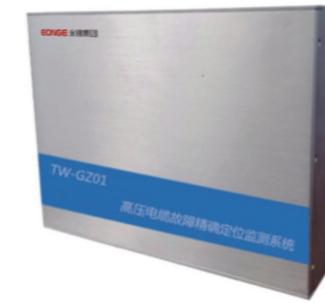

一体化监测装置  
Integrated Monitoring Device

### 系统技术参数: System Specifications:

通用性能 General Performance	
定位精度 Location Accuracy	≤10m
通讯方式 Communication Method	光纤通讯 Optical Fiber/4G/5G
故障定位响应时间 Fault Location Response Time	≤5min
工作温度 Operating Temp	-40°C~80°C
供电方式 Power Supply	AC220V/太阳能 Solar/自取电 Self-powered
防护等级 Protection Grade	IP68

### 技术优势

### Technical Advantage

- **精准定位 Precision Fault Location:**  
北斗高精度授时、电缆铠装同步授时、高精度晶振加密算法校准。避免恶劣天气对GPS授时影响,提高授时的可靠性,确保故障定位的精度。  
High-precision timing via BDS and cable armor synchronization, combined with calibration using a high-stability crystal oscillator encryption algorithm. Mitigates the impact of adverse weather on GPS timing to enhance synchronization reliability and ensure fault location accuracy.
- **缺陷判断 Defect Detection:**  
工频电流、行波、局放同时采样,可提前发现电缆缺陷,并快速精确定位缺陷位置。  
Simultaneous sampling of power frequency current, traveling waves, and partial discharge (PD) enables early detection of cable defects and rapid, precise localization of defect points.
- **故障预警 Fault Early Warning:**  
采用条线关联的故障预警模式,统计TDR(时域反射),确定故障类型并预警。  
Utilizes a line correlation-based early warning model. Analyzes TDR (Time Domain Reflectometry) data to identify fault types and trigger timely alerts.
- **智能算法 Intelligent Algorithm:**  
采用时间差测量(双端测量),分布式结构配置,快速计算相邻设备同步信号,并计算信号的时间差,精确定位信号源头,准确率达99%。  
Employs the time difference method (two-terminal measurement) in a distributed architecture. Rapidly calculates synchronous signals from adjacent devices and their time differences to pinpoint the signal source with an accuracy rate of 99%.

## 电缆防外力破坏预警系统 Cable External Damage Prevention and Early Warning System

### 产品简介 Product Introduction

系统通过振动识别、影像识别和物联网技术,打造具有实时感知功能的“地下管线卫士”(微拍+地钉+警示桩+光纤震动预警技术)。可24小时在线监测,对地下管线进行防外破报警,增强管线运维效率,保障管线通道安全稳定运行,支撑管线精益化管理。

Powered by vibration recognition, image recognition, and IoT technologies, the system acts as a “Underground Pipeline Guardian” with real-time awareness capabilities. This integrated solution combines fiber optic vibration early warning with micro-cameras, ground pegs, and warning posts for comprehensive protection. The system enables 24/7 online monitoring to detect third-party intrusion, significantly improving O&M efficiency, ensuring the safe and stable operation of pipeline routes, and supporting the lean management of pipeline assets.



### 智能电缆通道防外破地钉 Intelligent Cable Route Anti-Intrusion Ground Pegs

### 产品简介 Product Introduction

电缆通道防外破地钉被称为:地下电缆的智能守护哨兵,电缆通道防外破地钉是一种安装在地下电缆路径上方的智能监测与警示装置,核心作用是标识电缆走向和实时监测异常施工活动,提前预警外破风险,保障电网安全稳定运行。

Hailed as the "Intelligent Guardian of Underground Cables", this device is an intelligent monitoring and warning unit installed above underground cable routes. Its core functions include marking cable alignment, detecting abnormal construction activities in real time, issuing early warnings against third-party damage risks, and ensuring the safe and stable operation of the power grid.

### 产品特点 Product Features

- **震动感知 Vibration Perception:**  
全域监测无死角  
Full-Coverage Monitoring with No Blind Zones
- **多传感融合技术 Multi-Sensor Fusion Technology:**  
内置高精度北斗定位模块、三轴加速度传感器与压片震动传感装置,可实时捕捉 10 米半径内的机械钻孔、挖掘机碾压、人工开挖等多施工震动信号;  
Equipped with a high-precision BDS positioning module, a three-axis acceleration sensor, and a pressure plate vibration sensor, the peg captures various construction-induced vibration signals in real time within a radius of 10 m. These signals include mechanical drilling, excavator compaction, and manual excavation.
- **预警响应 Early Warning Response:**  
风险信息实时触达  
Real-Time Risk Notification
- **实时预警机制 Real-Time Early Warning Mechanism:**  
根据震动强度与持续时间,自动触发后台预警,通过 4G/GAT-1 双通信链路,将预警信息推送至运维人员手机 APP、监控平台及施工单位管理系统;  
Based on vibration intensity and duration, the system automatically triggers background alerts. Via dual 4G/GAT 1 communication links, alert information is instantly pushed to the mobile apps of O&M personnel, the central monitoring platform, and the management systems of construction entities.



地钉产品及应用  
Ground Pegs & Application

### 光纤振动预警技术 Optical fiber vibration early warning technology

采用光纤作为振动监测和信息传输载体,应用多重模式识别方法,提取振动信号,通过大数据分析排除干扰,根据光纤振动技术对振动源进行精确定位。主要由探测光纤、主机、高清摄像头、信息接收终端和供电单元等组成。

Optical fiber is adopted as the carrier for vibration monitoring and information transmission. Multi-pattern recognition technology is applied to extract vibration signals; interference is eliminated via big data analysis, and the vibration source is precisely located based on optical fiber vibration sensing technology. The system is primarily composed of a detection optical fiber, main unit, high-definition camera, information receiving terminal, and power supply unit.

参数名称Parameter Name	技术参数Technical Specifications
定位精度 Location Accuracy	最远 Up to 30Km
通讯方式 Communication Method	5m
故障定位响应时间 Fault Location Response Time	0.2S
工作温度 Operating Temp	多点同步测量 Multi-Point Synchronous Measurement

## 免维护无线环流监测系统

Maintenance-free Wireless Circulating Current Monitoring System

### 产品简介

#### Product Introduction

免维护无线环流监测终端,有以下特点

Maintenance-free Wireless Circulating Current Monitoring Terminal. Key Features:

- 接地箱护层环流实时监测,及时发现异常电流故障后台自动报警,保障电缆安全运行;

#### Real-time Sheath Circulation Monitoring

Continuously monitors sheath circulating current in earthing boxes. Detects abnormal current faults and triggers automatic background alarms to ensure safe cable operation.

- 外置式设计,可适用于存量电缆系统,可后期加装或改装;

#### External Mount Design

Compatible with existing cable systems, enabling easy retrofitting or field upgrades.

- 便携式设计,体积小,安装方便,现场设备安装调试仅10分钟;

#### Portable & Easy Installation

Compact design allows on-site installation and commissioning in as little as 10 minutes.

- 免维护理念,采用超低功耗设计,标配锂电池,GPRS通信方式可以使用5年以上。

#### True Maintenance-free Operation

Ultra-low power consumption with a standard lithium battery, supporting GPRS communication for over 5 years without servicing.

### 适用范围

#### Application Scope

适用于普通接地箱智能化改造,监测电缆接地系统环流,发现环流异常、接地连接错位、外护套破损、接地不良等缺陷,降低一线巡视、检测工作量。

Ideal for the intelligent upgrade of conventional earthing boxes. The terminal monitors circulating current in cable earthing systems to detect faults including abnormal circulation, misplaced earthing connections, damaged outer sheaths, and poor earthing integrity, significantly reducing front-line inspection and testing workloads.

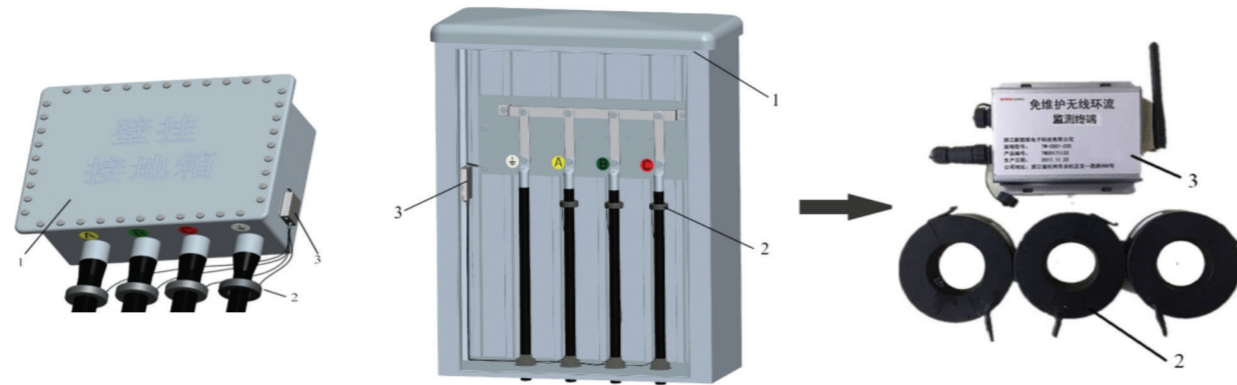

- 1、接地箱 Earthing box
- 2、电流传感器 Current Transducer
- 3、监测终端主机 Monitoring Terminal Main Unit

### 功能特点

#### Function Features

- 实时监测 Real-time Monitoring
- 外置设计 External Design
- 体积小 Compact Size
- 免维护 Maintenance-free

## 综合智能接地箱

Comprehensive Intelligent Earthing Box

### 产品简介

#### Product Introduction

高压电缆综合智能接地箱主要由箱体、接地装置、传感器、电缆运行状态监测箱(监测模块)及监测软件组成。该产品聚焦电缆运行安全,实现电缆运行状态数据和电缆通道环境量数据实时在线监测及数据管理,具备功能模块化、灵活取电、多样组网和集成管理等优势,可提高电缆运行安全性、经济性。

The high-voltage cable comprehensive intelligent earthing box mainly comprises a cabinet, earthing device, sensors, cable operation status monitoring unit (monitoring module) and monitoring software. Focusing on cable operational safety, it enables real-time online monitoring and data management of cable operation status data and cable route environmental data. Boasting functional modularization, flexible power supply, diverse networking and integrated management, the box enhances the operational safety and economic efficiency of cable systems.



#### 功能模块化: Functional Modularity

- 模块化设计  
Modular Design
- 模块化安装  
Modular Installation
- 模块化检修  
Modular Maintenance

#### 灵活取电: Flexible Power Supply

- 交流感应取电  
AC Inductive Power Harvesting
- 太阳能供电  
Solar Power Supply
- 蓄电池  
Backup Battery

#### 多样组网: Diverse Networking

- 安全可靠  
Safe & Reliable
- 组网灵活  
Flexible Networking
- 方便维护  
Easy Maintenance

#### 集成管理: Integrated Management

- 数据可靠  
Data Management
- 电池管理  
Battery Management
- 通讯管理  
Communication Management

## 高压交联电力电缆附件产品特点 Technical Features of High-Voltage XLPE Power Cable Accessories

- 1.从2000年开始制造电力电缆附件产品。  
Manufacturing experience in power cable accessories since 2000.
- 2.采取计算机设计软件对产品进行电场分布计算,不同电压等级的产品采取多种方法控制电场;  
Electric field distribution calculated via professional computer-aided design software, multi-method electric field control applied for products of different voltage classes.
- 3.采用特种液体硅橡胶原材料;  
Premium special liquid silicone rubber materials adopted.
- 4.所有复合应力锥、中间接头主体、环氧树脂套管等主要绝缘部件,均百分之百通过出厂电气检测;  
100% factory electrical testing passed for all key insulating components, including composite stress cones, joint bodies and epoxy resin bushings.
- 5.可配合内置式导体在线测温装置,局放装置技术;  
Compatible with built-in conductor online temperature monitoring and partial discharge detection technologies.

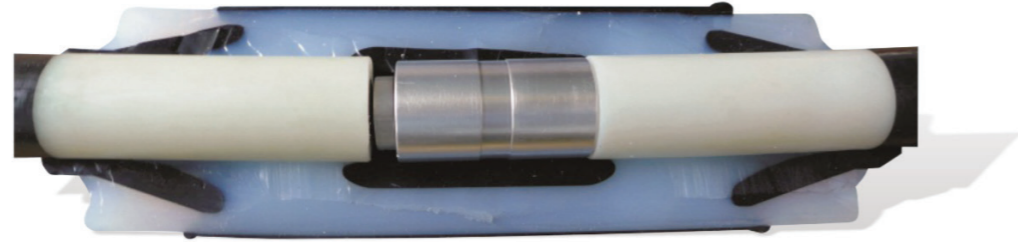

电缆中间接头——带导体在线测温装置  
Cable Joints - With Conductor Online Temperature Measurement Device



预制电缆终端电场分布  
Electric Field Distribution of Pre-molded Cable Terminations

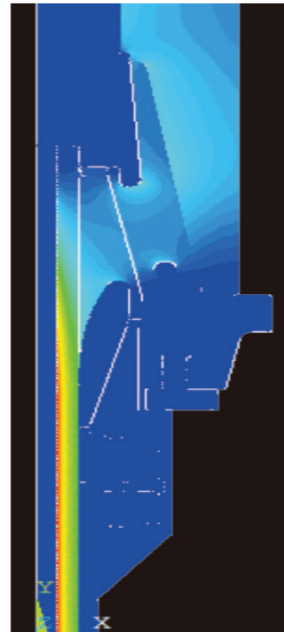

GIS终端电场分布  
Electric Field Distribution of GIS Terminations

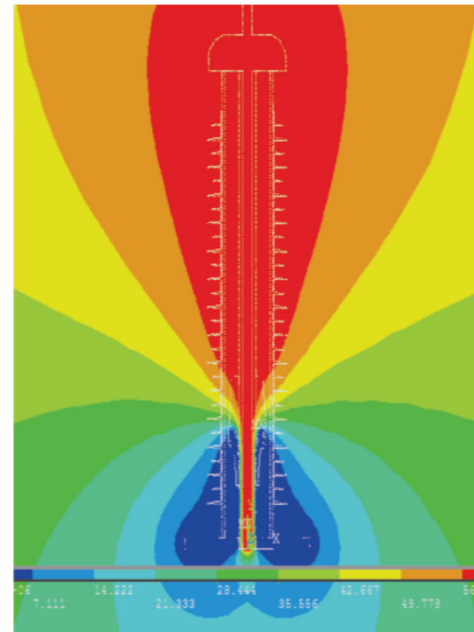

复合套管电缆终端电场分布  
Electric Field Distribution of Composite Bushing Cable Terminations

### 高压交联电力电缆附件产品基本技术参数表:

Basic Technical Parameters of High-Voltage XLPE Power Cable Accessories:

50/66kV电缆附件技术参数50/60kV Cable Accessories Technical Parameters	
额定电压 Rated Voltage, $U_0/U (U_m)$	50/66 (72.5) kV
工频耐压试验(湿态) Power Frequency Withstand Voltage Test (Wet Condition)	140kV, 1min
局部放电试验(室温) PD Test (Room Temp)	1.5 $U_0$ 下, 无可探测的局放No detectable partial discharge at 1.5 $U_0$
恒压负荷热循环试验 Constant Voltage Withstand Thermal Cycle Test	2.0 $U_0$ , 20次热循环(20 thermal cycles)
局部放电试验(高温) PD Test (High Temp)	1.5 $U_0$ 下, 无可探测的局放No detectable partial discharge at 1.5 $U_0$
雷电冲击电压试验 Lightning Impulse Voltage Test	450kV, $\pm 10$ 次 ( $\pm 10$ applications)
雷电冲击后工频电压试验 Power Frequency Withstand Voltage Test After Lightning Impulse	2.5 $U_0$ , 15min
64/110kV电缆附件技术参数64/110 kV Cable Accessories Technical Parameters	
额定电压 Rated Voltage, $U_0/U (U_m)$	64/110 (126) kV
工频耐压试验(湿态) Power Frequency Withstand Voltage Test (Wet Condition)	185kV, 1min
局部放电试验(室温) PD Test (Room Temp)	1.5 $U_0$ 下, 无可探测的局放No detectable partial discharge at 1.5 $U_0$
恒压负荷热循环试验 Constant Voltage Withstand Thermal Cycle Test	2.0 $U_0$ , 20次热循环(20 thermal cycles)
局部放电试验(高温) PD Test (High Temp)	1.5 $U_0$ 下, 无可探测的局放No detectable partial discharge at 1.5 $U_0$
雷电冲击电压试验 Lightning Impulse Voltage Test	550kV, $\pm 10$ 次 ( $\pm 10$ applications)
雷电冲击后工频电压试验 Power Frequency Withstand Voltage Test After Lightning Impulse	2.5 $U_0$ , 15min
127/220kV电缆附件技术参数127/220 kV Cable Accessories Technical Parameters	
额定电压 Rated Voltage, $U_0/U (U_m)$	127/220 (252) kV
工频耐压试验(湿态) Power Frequency Withstand Voltage Test (Wet Condition)	460kV, 1min
局部放电试验(室温) PD Test (Room Temp)	1.5 $U_0$ 下, 无可探测的局放No detectable partial discharge at 1.5 $U_0$
恒压负荷热循环试验 Constant Voltage Withstand Thermal Cycle Test	2.0 $U_0$ , 20次热循环(20 thermal cycles)
局部放电试验(高温) PD Test (High Temp)	1.5 $U_0$ 下, 无可探测的局放No detectable partial discharge at 1.5 $U_0$
雷电冲击电压试验 Lightning Impulse Voltage Test	1050kV, $\pm 10$ 次 ( $\pm 10$ applications)
雷电冲击后工频电压试验 Power Frequency Withstand Voltage Test After Lightning Impulse	2.5 $U_0$ , 15min
预鉴定试验Pre-qualification Test	8760h, 216kV 180次热循环后, 雷电冲击电压 1050kV, $\pm 10$ 次After 180 thermal cycles: Lightning Impulse Voltage 1050 kV, $\pm 10$ applications
290/500kV电缆附件技术参数290/500kV Cable Accessories Technical Parameters	
额定电压 Rated Voltage, $U_0/U (U_m)$	290/500 (550) kV
工频耐压试验(湿态) Power Frequency Withstand Voltage Test (Wet Condition)	460kV, 1min
局部放电试验(室温) PD Test (Room Temp)	1.5 $U_0$ 下, 无可探测的局放No detectable partial discharge at 1.5 $U_0$
恒压负荷热循环试验 Constant Voltage Withstand Thermal Cycle Test	2.0 $U_0$ , 20次热循环(20 thermal cycles)
局部放电试验(高温) PD Test (High Temp)	1.5 $U_0$ 下, 无可探测的局放No detectable partial discharge at 1.5 $U_0$
操作冲击电压试验 Switching Impulse Voltage Test	1175kV, $\pm 10$ 次 ( $\pm 10$ applications)
雷电冲击电压试验 Lightning Impulse Voltage Test	1550kV, $\pm 10$ 次 ( $\pm 10$ applications)
雷电冲击后工频电压试验 Power Frequency Withstand Voltage Test After Lightning Impulse	2.5 $U_0$ , 15min
预鉴定试验Pre-qualification Test	8760h, 493kV 180次热循环后, 雷电冲击电压 1550kV, $\pm 10$ 次After 180 thermal cycles: Lightning Impulse Voltage 1550 kV, $\pm 10$ applications

66-500kV交联聚乙烯绝缘电力电缆用复合套管/瓷套管终端  
66-500kV Composite / Porcelain Bushing Terminals for XLPE Insulated Power Cables

产品符合 Complies with

- IEC60840《额定电压30kV (Um=36kV) 以上至150kV (Um=170kV) 挤包绝缘电缆及其附件》  
IEC 60840 Extruded Insulated Power Cables with Accessories for Rated Voltages above 30kV (Um = 36kV) up to 150kV (Um = 170kV)
- IEC62067《额定电压150kV (Um=170kV) 以上至500kV (Um=550kV) 挤包绝缘电缆及其附件》  
IEC 62067 Extruded Insulated Power Cables with Accessories for Rated Voltages above 150kV (Um = 170kV) up to 500kV (Um = 550kV)
- GB/T22078.3《额定电压500kV交联聚乙烯绝缘电力电缆及其附件 第三部分: 电缆附件》  
GB/T 22078.3 Power Cables with Cross-Linked Polyethylene Insulation and Accessories for Rated Voltage 500kV – Part 3: Cable Accessories
- GB/T18890.3《额定电压220kV交联聚乙烯绝缘电力电缆及其附件 第三部分: 电缆附件》  
GB/T 18890.3 Power Cables with Cross-Linked Polyethylene Insulation and Their Accessories for Rated Voltage 220kV – Part 3: Cable Accessories
- GB/T11017.3《额定电压66kV和110kV交联聚乙烯绝缘电力电缆及其附件 第三部分: 电缆附件》  
GB/T 11017.3 Power Cables with Cross-Linked Polyethylene Insulation and Accessories for Rated Voltage 66kV and 110kV – Part 3: Cable Accessories

适用范围 Application Scope

额定电压Rated Voltage:	适用截面Applicable Cross-Section:
50/66kV	240-1600mm <sup>2</sup>
64/110kV	240-2000mm <sup>2</sup>
127/220kV	400-2500mm <sup>2</sup>
290/500kV	800-2500mm <sup>2</sup>



产品型号 Model

复合套管终端YJZWY4; 瓷套管终端YJZY4; 适用于户外e级污秽等级;  
Composite Bushing Terminal YJZWY4; Porcelain Bushing Terminal YJZY4; Suitable for outdoor Pollution Class E

技术特点 Technical Features

- 复合套管终端, 具有良好的机械物理性能, 良好的防爆性能;  
Composite bushing terminals feature excellent mechanical and physical properties as well as superior explosion-proof performance.
- 复合套管终端, 其硅橡胶外套为大小伞裙交替型, 具有良好的耐污性能;  
The silicone rubber housing of composite bushing terminals adopts an alternating large and small shed design, delivering outstanding anti-pollution performance.
- 瓷套管终端选用高强度特制瓷瓶, 具有良好的耐候性, 抗漏电起痕能力强;  
Porcelain bushing terminals adopt high-strength custom porcelain insulators, with excellent weather resistance and high anti-tracking capability.
- 界面压紧力增强型电应力控制锥;  
Electric stress control cone with enhanced interface compression force.
- 应力锥选用特种液体硅橡胶制造;  
Stress cones are manufactured from special liquid silicone rubber.
- 内部填充高分子绝缘混合剂, 性能稳定;  
Filled with polymer insulating mixture inside for stable performance.

产品外形图 Product Outline Drawing

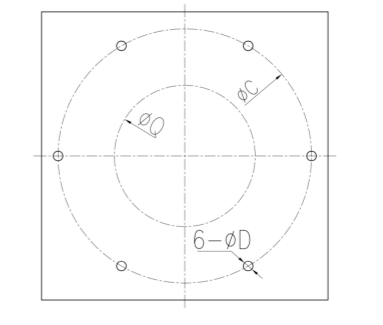
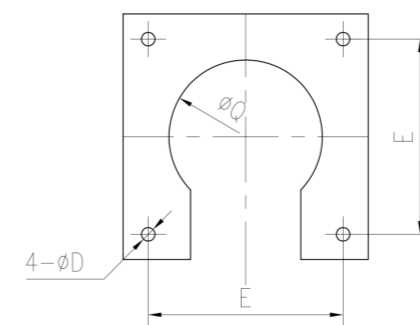
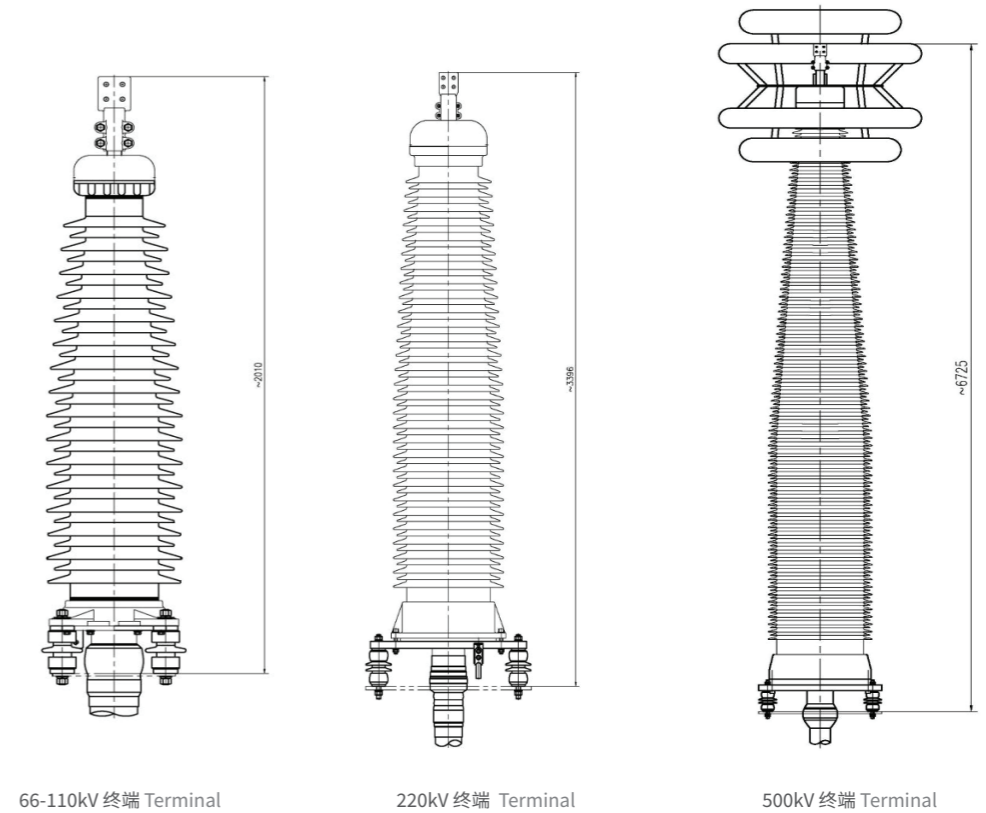

电压等级Voltage Classes	D mm	E mm	Q mm	C mm
66-110kV	22	318	200	/
220kV	35	566	400	/
500kV	35	/	500	900

66-500kV交联聚乙烯绝缘电力电缆用干式绝缘GIS(变压器)装配式/插拔式终端  
66-500kV Dry Insulation GIS (Transformer) Assembled/Plug-in Terminations for XLPE Insulated Power Cables

产品符合 Complies with

- IEC60840《额定电压30kV(Um=36kV)以上至150kV(Um=170kV)挤包绝缘电缆及其附件》  
IEC 60840 Extruded Insulated Power Cables with Accessories for Rated Voltages above 30kV (Um = 36kV) up to 150kV (Um = 170kV)
- IEC62067《额定电压150kV(Um=170kV)以上至500kV(Um=550kV)挤包绝缘电缆及其附件》  
IEC 62067 Extruded Insulated Power Cables with Accessories for Rated Voltages above 150kV (Um = 170kV) up to 500kV (Um = 550kV)
- IEC62271-209《额定电压52kV以上的气体绝缘金属封闭开关设备与与充流体及挤包绝缘电力电缆的连接 充流体及干式电缆终端》  
IEC 62271-209 Connections for Gas-Insulated Metal-Enclosed Switchgear (GIS) and Power Cables with Fluid-Filled or Extruded Insulation for Rated Voltages above 52kV – Fluid-Filled and Dry Cable Terminations
- GB/T22078.3《额定电压500kV交联聚乙烯绝缘电力电缆及其附件 第三部分:电缆附件》  
GB/T 22078.3 Power Cables with Cross-Linked Polyethylene Insulation and Accessories for Rated Voltage 500kV – Part 3: Cable Accessories
- GB/T18890.3《额定电压220kV交联聚乙烯绝缘电力电缆及其附件 第三部分:电缆附件》  
GB/T 18890.3 Power Cables with Cross-Linked Polyethylene Insulation and Their Accessories for Rated Voltage 220kV – Part 3: Cable Accessories
- GB/T11017.3《额定电压66kV和110kV交联聚乙烯绝缘电力电缆及其附件 第三部分:电缆附件》  
GB/T 11017.3 Power Cables with Cross-Linked Polyethylene Insulation and Accessories for Rated Voltage 66kV and 110kV – Part 3: Cable Accessories
- GB/T22381《额定电压72.5kV及以上气体绝缘金属封闭开关设备与充流体及挤包绝缘电力电缆的连接 充流体及干式电缆终端》  
GB/T 22381 Connections for Gas-Insulated Metal-Enclosed Switchgear (GIS) and Power Cables with Fluid-Filled or Extruded Insulation for Rated Voltages 72.5kV and Above – Fluid-Filled and Dry Cable Terminations

适用范围 Application Scope

额定电压Rated Voltage:	适用截面Applicable Cross-Section:
50/66kV	240-1600mm <sup>2</sup>
64/110kV	240-2000mm <sup>2</sup>
127/220kV	400-2500mm <sup>2</sup>
290/500kV	800-2500mm <sup>2</sup>

产品型号 Model

装配式 Assembled Type: YJZGG-R;  
插拔式 Plug-in: YJZGG-B



GIS终端现场运行图  
GIS Terminal On-site Operation Photo

技术特点 Technical Features

1. 预制电应力控制锥选用特种液体硅橡胶制造;  
Pre-molded electric stress control cones manufactured from special liquid silicone rubber.
2. 选用新型双酚环氧, 真空浇注, 机械电气性能优良;  
New bisphenol epoxy resin, vacuum-cast, with excellent mechanical and electrical properties.
3. 弹簧压紧, 全干式, 不用灌注绝缘介质, 可避免产品在运行过程中的漏油现象;  
Spring-loaded compression, fully dry design (no insulating medium filling), avoiding oil leakage during operation.
4. 可安装智能测温元件, 对电缆运行状态在线监测;  
Compatible with intelligent temperature measurement components for online cable status monitoring.
5. “装配式”传统安装方式: 先将产品整体安装, 再插入GIS组合电器(变压器)电缆终端仓内;  
"Assembled" installation: Install the entire product first, then insert into GIS (transformer) cable terminal compartment.
6. “插拔式”可插拔安装方式: 先将环氧套管安装于GIS组合电器(变压器)电缆终端仓内, 再将电缆及应力锥插入环氧套管  
"Plug-in" installation: Install epoxy bushing in GIS (transformer) compartment first, then insert cable and stress cone into the bushing.

产品外形图 Product Outline Drawing

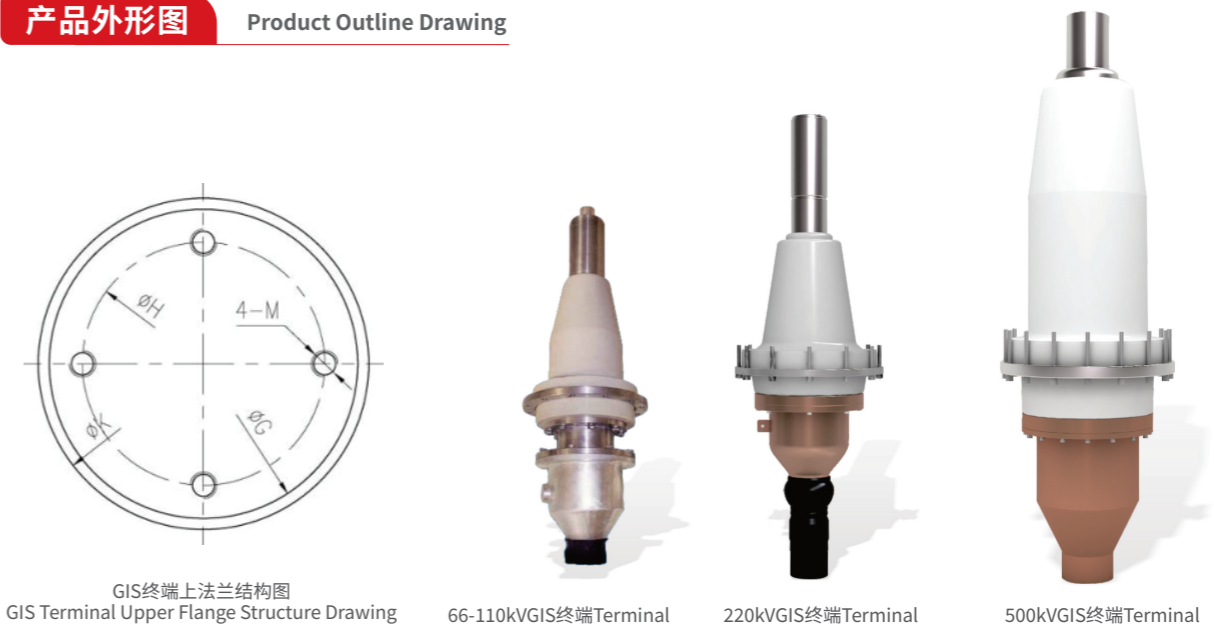

GIS终端上法兰结构图  
GIS Terminal Upper Flange Structure Drawing  
66-110kV GIS终端 Terminal  
220kV GIS终端 Terminal  
500kV GIS终端 Terminal

电压等级Voltage Classes	K mm	G mm	H mm	M mm	L mm
66-110kV	110	100	80	M10	470/757
220kV	150	140	110	M12	620/960
500kV	150	140	110	M12	960/1400

66-500kV交联聚乙烯绝缘电力电缆用整体预制硅橡胶中间接头  
66-500kV Integrally Pre-molded Silicone Rubber Joints for XLPE Insulated Power Cables

产品符合 Complies with

- IEC60840《额定电压30kV (Um=36kV) 以上至150kV (Um=170kV) 挤包绝缘电缆及其附件》  
IEC 60840 Extruded Insulated Power Cables with Accessories for Rated Voltages above 30kV (Um = 36kV) up to 150kV (Um = 170kV)
- IEC62067《额定电压150kV (Um=170kV) 以上至500kV (Um=550kV) 挤包绝缘电缆及其附件》  
IEC 62067 Extruded Insulated Power Cables with Accessories for Rated Voltages above 150kV (Um = 170kV) up to 500kV (Um = 550kV)
- GB/T22078.3《额定电压500kV交联聚乙烯绝缘电力电缆及其附件 第三部分：电缆附件》  
GB/T 22078.3 Power Cables with Cross-Linked Polyethylene Insulation and Accessories for Rated Voltage 500kV – Part 3: Cable Accessories
- GB/T18890.3《额定电压220kV交联聚乙烯绝缘电力电缆及其附件 第三部分：电缆附件》  
GB/T 18890.3 Power Cables with Cross-Linked Polyethylene Insulation and Their Accessories for Rated Voltage 220kV – Part 3: Cable Accessories
- GB/T11017.3《额定电压66kV和110kV交联聚乙烯绝缘电力电缆及其附件 第三部分：电缆附件》  
GB/T 11017.3 Power Cables with Cross-Linked Polyethylene Insulation and Accessories for Rated Voltage 66kV and 110kV – Part 3: Cable Accessories

适用范围 Application Scope

额定电压Rated Voltage:	适用截面Applicable Cross-Section:
50/66kV	240-1600mm <sup>2</sup>
64/110kV	240-2000mm <sup>2</sup>
127/220kV	400-2500mm <sup>2</sup>
290/500kV	800-2500mm <sup>2</sup>



66-500kV中间接头主体  
66-500kV XLPE Cable Joint Body

技术特点 Technical Features

1. 接头主体为整体预制式，安装方便；  
Integrally pre-molded joint body for easy installation.
2. 接头主体选用特种液体硅橡胶；  
Joint body made of special liquid silicone rubber.
3. 内屏蔽管，绝缘层，外导电层紧密复合；  
Tightly bonded inner shield tube, insulation layer, and outer conductive layer.
4. 根据现场安装条件，接头的外部密封防护可多种选择；  
Multiple external sealing and protection options available based on on-site installation conditions.

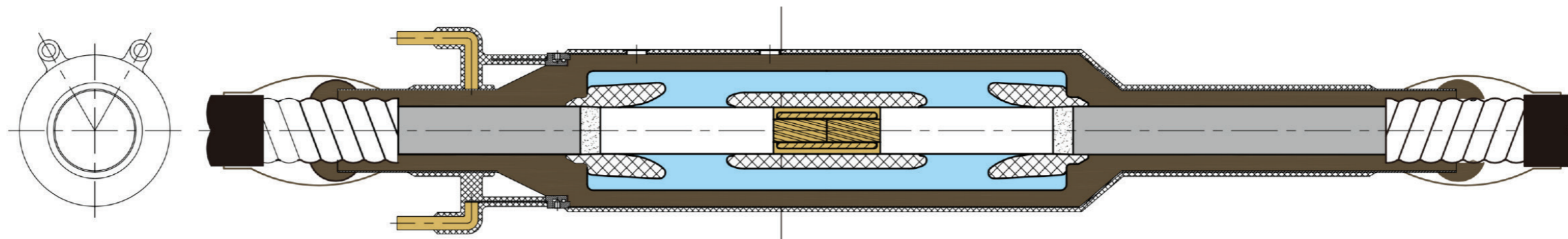

产品型号 Model

绝缘型 Insulated Type: YJJJI-X

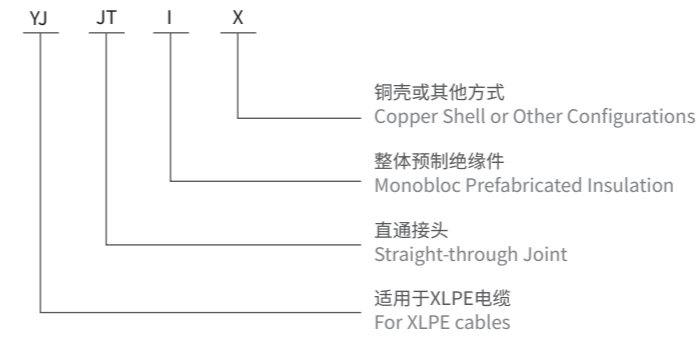

直通型 Straight-through Type: YJJTI-X

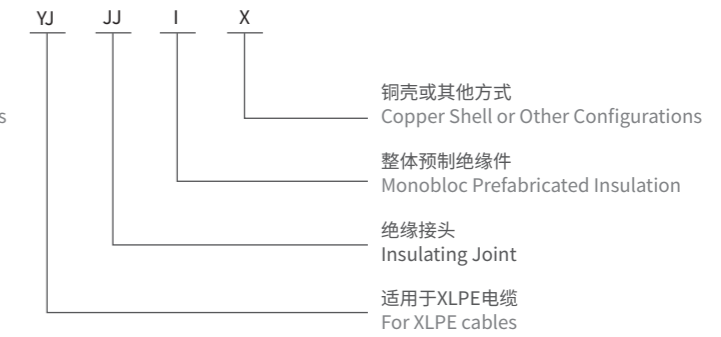

中间接头主体半剖图 Half-section View of Cable Joint Body



中间接头铜壳 Copper Shell of Cable Joint

## 66-138kV交联聚乙烯绝缘电力电缆用整体预制干式绝缘户外终端

66-138kV Integrally Pre-molded Dry Insulation Outdoor Terminations for XLPE Insulated Power Cables

### 产品符合 Complies with

- EC60840《额定电压3..0kV (Um=36kV) 以上至150kV (Um=170kV) 挤包绝缘电缆及其附件》  
IEC 60840 Extruded Insulated Power Cables with Accessories for Rated Voltages above 30kV (Um = 36kV) up to 150kV (Um = 170kV)
- GB/T11017.3《额定电压66kV和110kV交联聚乙烯绝缘电力电缆及其附件第三部分: 电缆附件》  
GB/T 11017.3 Power Cables with Cross-Linked Polyethylene Insulation and Accessories for Rated Voltage 66kV and 110kV – Part 3: Cable Accessories

### 适用范围 Application Scope

额定电压Rated Voltage:	适用截面Applicable Cross-Section:
50/66kV	240-1600mm <sup>2</sup>
64/110kV	240-2000mm <sup>2</sup>
76/138kV	240-2500mm <sup>2</sup>

### 产品型号 Model

长款Long Type: YJZWG4-L  
短款Short Type: YJZWG4-S;  
适用Application: 户外e级污秽等级 Outdoor, Pollution Class E

### 技术特点 Technical Features

- 自主研发, 科技含量高, 国家专利产品, 发明专利号: ZL2010 1 0582216.5;  
Independent R&D, high technological content, national patent product (Patent No.: ZL2010 1 0582216.5).
- 硅橡胶柔性整体结构, 产品的应力锥及绝缘主体, 伞裙全部复合成为一个整体;  
Flexible integral silicone rubber structure: stress cone, insulation body, and sheds are integrally bonded.
- 大小伞裙交替整体覆盖, 无纵向合模缝, 消除了机械应力, 提高了产品的预期运行寿命;  
Alternating large and small sheds with no longitudinal mold seams, eliminating mechanical stress and extending service life.
- 产品采用具有高抗漏电起痕, 高强度, 高弹性的进口特种液体硅橡胶, 能适合高污秽地区;  
Imported special liquid silicone rubber with high anti-tracking capability, high strength, and elasticity—suitable for high-pollution areas.
- 干式结构产品不用添加任何绝缘油等浇注剂, 杜绝了漏油情况的发生;  
Dry structure with no insulating oil filling, eliminating oil leakage risks.
- 产品重量轻, 只有传统瓷套式终端重量的1/10;  
Lightweight (1/10 of traditional porcelain bushing terminals).
- 产品制造高度可以按照用户要求进行调整;  
Customizable height per user requirements.
- 产品的安装位置不受限制, 可以直立, 也可以倾斜一定的角度, 不影响运行质量;  
Flexible installation (vertical or inclined) without affecting performance.
- 产品具有防爆性和阻燃性, 安全性高, 属于绿色环保型产品;  
Explosion-proof, flame-retardant, and environmentally friendly.

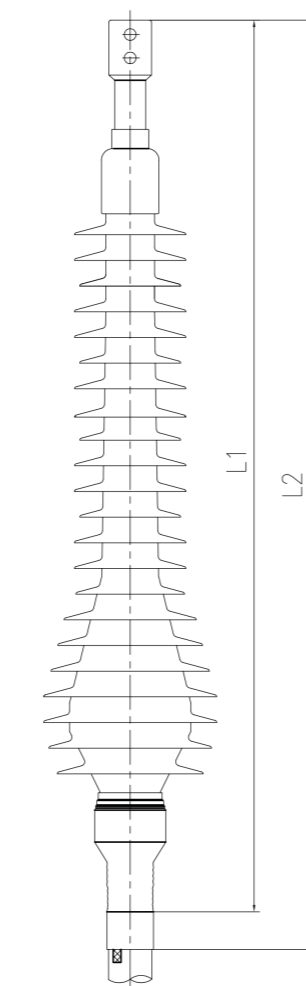

干式终端图  
Dry-type termination drawing

电压等级 Voltage Classes	L <sub>1</sub> mm	L <sub>2</sub> mm
66kV	1519	1569
110kV	1869	1919
138kV	1869	1919

## 66-110kV交联聚乙烯绝缘电力电缆用分支接头

66-110kV T-junctions for XLPE Insulated Power Cables

### 产品符合 Complies with

- IEC60840《额定电压30kV (Um=36kV) 以上至150kV (Um=170kV) 挤包绝缘电缆及其附件》  
IEC 60840 Extruded Insulated Power Cables with Accessories for Rated Voltages above 30kV (Um = 36kV) up to 150kV (Um = 170kV)
- GB/T11017.3《额定电压66kV和110kV交联聚乙烯绝缘电力电缆及其附件 第三部分: 电缆附件》  
GB/T 11017.3 Power Cables with Cross-Linked Polyethylene Insulation and Accessories for Rated Voltage 66kV and 110kV – Part 3: Cable Accessories

### 适用范围 Application Scope

额定电压Rated Voltage:	适用截面Applicable Cross-Section:
50/66kV	240-1600mm <sup>2</sup>
64/110kV	240-1600mm <sup>2</sup>

### 产品型号 Model

YJJFG

### 技术特点 Technical Features

- 分支接头主体在公司内部预装成型, 现场安装时仅将电缆头插入即可使用  
Pre-assembled joint body at the factory; on-site installation only requires inserting cable ends.
- 采用进口树脂原料, 现场浇注成型工艺, 逐只X光检测, 质量控制严格  
Imported resin raw materials, on-site casting molding, 100% X-ray inspection for strict quality control.
- 设计紧凑, 体积小, 重量轻, 安装占用空间少。适用于电缆沟、工井、直埋等场合  
Compact design, small size, lightweight, and space-saving—suitable for cable trenches, manholes, direct burial, etc.
- 可视安装环境选择使用安装防水、防爆壳。  
Optional waterproof and explosion-proof enclosures based on installation environment.

### 产品外形图 Product Outline Drawing

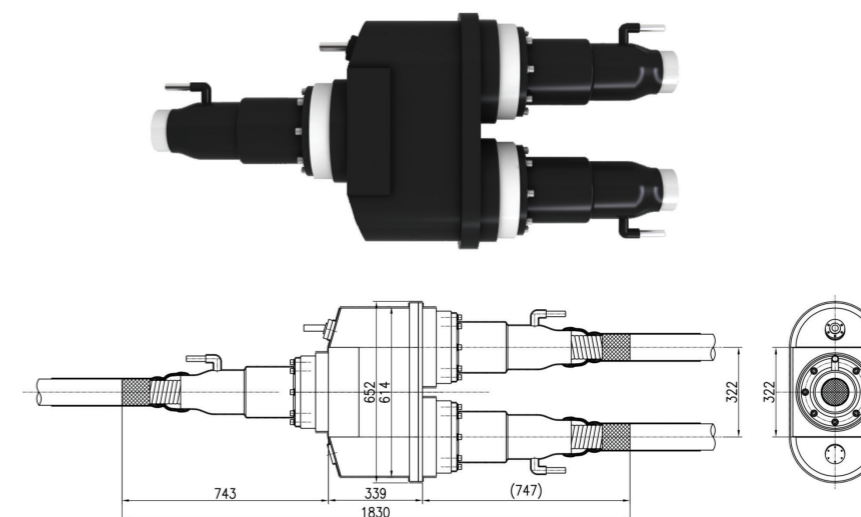

### 冷缩式电缆附件技术特点 Technical Features of Cold-shrink Cable Accessories

- 性能优异 Excellent Performance
- 采用高强度有机硅橡胶 Manufactured with high-strength silicone rubber
- 极强的抗漏电起痕能力 Excellent resistance to tracking and erosion
- 优良的耐辐射性能(可耐紫外线、X射线、Y射线) Good radiation resistance (UV, X-ray, γ-ray)
- 憎水性好,可迁移污物 Excellent hydrophobicity with hydrophobicity transfer
- 极佳的介电性能 Excellent dielectric performance
- 宽温度适用范围 (-50~+200°C) Wide operating temperature range (-50~+200°C)



优良的憎水性  
Excellent hydrophobicity

### 适用广泛 Wide Application

一种型号可适用多种电缆线径。能应用于盐雾地区,严寒地区,高温高湿地区。能适合电力,石化,钢铁,煤矿,铁道,油田多个行业。  
One model fits multiple cable sizes Suitable for salt-fog, cold, high-temperature, and high-humidity areas Applicable to power, petrochemical, steel, coal, railway, oilfield industries.



- 安装方便  
Easy Installation
- 安装不须动火,不用加热(无电源情况),可顺利安装  
No open flame or heating required (installable without power supply)



- 永锦自复位技术  
Eonge Self-resetting Technology
- 永锦全冷缩电缆附件已获两项国家专利  
Two national patents for Eonge full cold-shrink cable accessories.
- 现场安装时,将自复位组件套入电缆,然后拉出衬条或抽出衬条,硅橡胶部件,即自动复位。  
During on-site installation, sleeve the self-resetting component onto the cable, then pull out the backing strip—silicone rubber components automatically reset.

### 创新科技 Innovative Technology

- A型产品  
A Type Product
- 通过纳米改性应力管控制电应力(参数控制法)  
Nano-modified stress tube for electric field control (parameter control method)
- B型产品  
B Type Product
- 通过应力锥控制电应力(形状控制法)  
Stress cone for electric field control (shape control method)

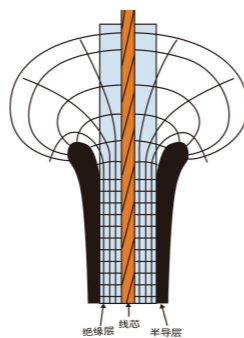
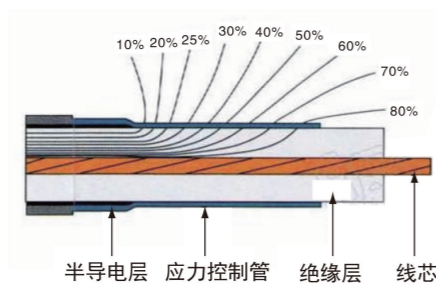

冷缩终端电场控制示意图 Cold-shrink Termination Electric Field Control Schematic

10~35kV交联电力电缆附件基础技术参数表 Basic Technical Parameters of 10~35kV HV Cable Accessories

序号No	检测项目Test Item	8.7/15kV	12/20kV	18/20 (30) kV	26/35kV
1	室温局放试验 Room Temp PD Test	15kV, <10pC	20kV, <10pC	31kV, <10pC	45kV, <10pC
2	工频耐压试验 Power Frequency Withstand Voltage Test	39kV, 5min 不击穿、不闪络 (No breakdown /flashover)	54kV, 5min 不击穿、不闪络 (No breakdown /flashover)	81kV, 5min 不击穿、不闪络 (No breakdown /flashover)	117kV, 5min 不击穿、不闪络 (No breakdown /flashover)
3	负荷循环试验60周期 Load Cycle Test (60 cycles)	在23kV导体温度(95~100°C)下共经受60个循环 60 cycles at 23kV, conductor temp 95~100°C	在30kV导体温度(95~100°C)下共经受60个循环 60 cycles at 30kV, conductor temp 95~100°C	在45kV导体温度(95~100°C)下共经受60个循环 60 cycles at 45kV, conductor temp 95~100°C	在65kV导体温度(95~100°C)下共经受60个循环 60 cycles at 65kV, conductor temp 95~100°C
4	冲击电压试验 Impulse Voltage Test	95kV, 正负各10次 不击穿、不闪络 95kV, ±10 times (No breakdown /flashover)	125kV, 正负各10次 不击穿、不闪络 125kV, ±10 times (No breakdown /flashover)	170kV, 正负各10次 不击穿、不闪络 170kV, ±10 times (No breakdown /flashover)	200kV, 正负各10次 不击穿、不闪络 170kV, ±10 times (No breakdown /flashover)
5	高温局放试验 High Temp PD Test	15kV, <10pC	20kV, <10pC	31kV, <10pC	45kV, <10pC
6	工频耐压试验 Power Frequency Withstand Voltage Test	23kV, 15min 不击穿、不闪络 (No breakdown /flashover)	54kV, 15min 不击穿、不闪络 (No breakdown /flashover)	45kV, 15min 不击穿、不闪络 (No breakdown /flashover)	65kV, 15min 不击穿、不闪络 (No breakdown /flashover)
7	热稳定试验 Thermal Stability Test	24kA, 2S, 2次 (times)	24kA, 2S, 2次 (times)	24kA, 2S, 2次 (times)	24kA, 2S, 2次 (times)
8	动稳定试验 Dynamic Stability Test	85kA, ≥20ms	85kA, ≥20ms	85kA, ≥20ms	85kA, ≥20ms
9	潮湿试验(户内) Humidity Test (Indoor)	1.25U <sub>0</sub> , 300h	1.25U <sub>0</sub> , 300h	1.25U <sub>0</sub> , 300h	1.25U <sub>0</sub> , 300h
10	盐雾试验(户外) Salt Spray Test (Outdoor)	1.25U <sub>0</sub> , 1000h	1.25U <sub>0</sub> , 1000h	1.25U <sub>0</sub> , 1000h	1.25U <sub>0</sub> , 1000h

1~35kV冷缩式电缆附件  
1~35kV Cold-shrink Cable Terminations

产品符合 Complies with

- IEC60502.4《额定电压1kV到30kV挤包绝缘电力电缆及附件第四部分：电力电缆附件的试验要求》  
IEC 60502.4 Power Cables with Extruded Insulation and Accessories for Rated Voltages from 1kV to 30kV – Part 4: Test Requirements for Power Cable Accessories
- GB/T12706.4《额定电压1kV到35kV挤包绝缘电力电缆及附件第四部分：电力电缆附件的试验要求》  
GB/T 12706.4 Power Cables with Extruded Insulation and Accessories for Rated Voltages from 1kV to 35kV – Part 4: Test Requirements for Power Cable Accessories
- JB/T10740.1《额定电压6kV到35kV挤包绝缘电力电缆 冷收缩式附件 第一部分：终端》  
JB/T 10740.1 Cold-shrink Accessories for Power Cables with Extruded Insulation for Rated Voltages from 6kV to 35kV – Part 1: Terminations
- T/CEC 118《额定电压35kV及以下冷缩电缆附件技术规范》  
T/CEC 118 Technical Specification for Cold-shrink Cable Accessories for Rated Voltages up to 35kV

适用范围 Application Scope

额定电压 Rated Voltage: 0.6/1kV, 1.8/3kV, 8.7/15kV, 12/20kV, 18/(20-30) kV, 26/35kV  
 适用截面 Applicable Cross-Section: 10~630mm<sup>2</sup>  
 海拔高度 Altitude: 0~4500m  
 环境温度 Ambient Temperature: -40~+45°C  
 污秽等级 Pollution Class: e级污秽Class E

产品型号 Model

三芯户外终端 WLS3-电压-截面 Three-core Outdoor Termination: WLS3-Voltage-Cross-Section  
 三芯户内终端 NLS3-电压-截面 Three-core Indoor Termination: NLS3-Voltage-Cross-Section  
 单芯户外终端 WLS3-电压-截面 Single-core Outdoor Termination: WLS3-Voltage-Cross-Section  
 单芯户内终端 NLS3-电压-截面 Single-core Indoor Termination: NLS3-Voltage-Cross-Section  
 多芯户外终端WLS芯数-电压-截面 Multi-core Outdoor Termination: WLS3-Voltage-Cross-Section  
 多芯户内终端WLS芯数-电压-截面 Multi-core Indoor Termination: NLS3-Voltage-Cross-Section



B型户外锥式终端  
Type B Outdoor Cone-type Termination



B型户内锥式终端  
Type B Indoor Cone-type Termination

产品外形图 Product Outline Drawing

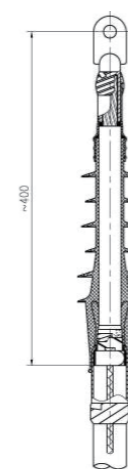

单芯锥式户外  
Single-core cone-type outdoor termination

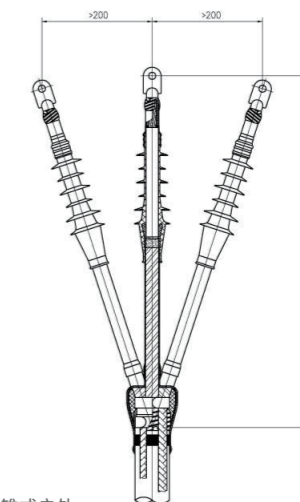

三芯锥式户外  
Three-core cone-type outdoor termination

户外终端外形尺寸 Outdoor Termination Dimensions

电压等级Rated Voltage	8.7/15kV、12/20kV	18/(20-30) kV	26/35kV
L1 mm	~200	~1100	~1500
L2 mm	~770	~300	~400
L3 mm	~400	~500	~700

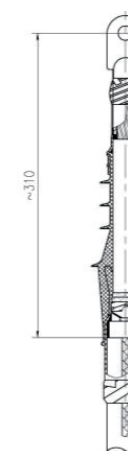

单芯锥式户内  
Single-core cone-type indoor termination

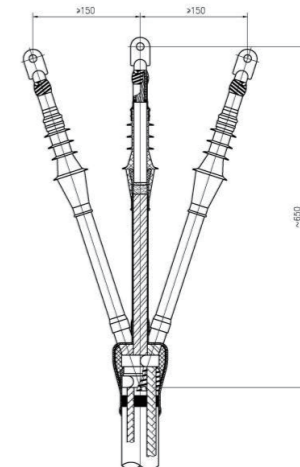

三芯锥式户内  
Three-core cone-type indoor termination

户内终端外形尺寸 Outdoor Termination Dimensions

电压等级Rated Voltage	8.7/15kV、12/20kV	18/(20-30) kV	26/35kV
L1 mm	~150	~950	~1200
L2 mm	~650	~180	~300
L3 mm	~310	~500	~600

## 1~35kV冷缩式电缆中间接头 1~35kV Cold-shrink Cable Joints

### 产品符合 Complies with

- IEC60502.4《额定电压1kV到30kV挤包绝缘电力电缆及附件第四部分：电力电缆附件的试验要求》  
IEC 60502.4 Power Cables with Extruded Insulation and Accessories for Rated Voltages from 1kV to 30kV – Part 4: Test Requirements for Power Cable Accessories
- GB/T12706.4《额定电压1kV到35kV挤包绝缘电力电缆及附件第四部分：电力电缆附件的试验要求》  
GB/T 12706.4 Power Cables with Extruded Insulation and Accessories for Rated Voltages from 1kV to 35kV – Part 4: Test Requirements for Power Cable Accessories
- JB/T10740.1《额定电压6kV到35kV挤包绝缘电力电缆 冷收缩式附件 第一部分：终端》  
JB/T 10740.1 Cold-shrink Accessories for Power Cables with Extruded Insulation for Rated Voltages from 6kV to 35kV – Part 1: Terminations
- T/CEC 118《额定电压35kV及以下冷缩电缆附件技术规范》  
T/CEC 118 Technical Specification for Cold-shrink Cable Accessories for Rated Voltages up to 35kV

### 适用范围 Application Scope

额定电压 Rated Voltage: 0.6/1kV, 1.8/3kV, 8.7/15kV, 12/20kV, 18/(20-30) kV, 26/35kV  
 适用截面 Applicable Cross-Section: 10~630mm<sup>2</sup>  
 海拔高度 Altitude: 0~4500m  
 环境温度 Ambient Temperature: -40~+45°C

### 产品型号 Model

三芯直通型中间接头 JLS3-电压-截面 Three-core Straight-through Joint: JLS3-Voltage-Cross-Section  
 单芯直通型中间接头 JLS1-电压-截面 Single-core Straight-through Joint: JLS1-Voltage-Cross-Section  
 单芯绝缘型中间接头 JLS1-JY-电压-截面 Single-core Insulated Joint: JLS1-JY-Voltage-Cross-Section  
 多芯中间接头 JLS3芯数-电压-截面 Multi-core Joint: JLS3-Voltage-Cross-Section



10-35kV冷缩中间接头  
10-35 kV Cold-shrink Cable Joint



26/35kV绝缘型冷缩中间接头26/35 kV  
Insulating Cold-shrink Cable Joint

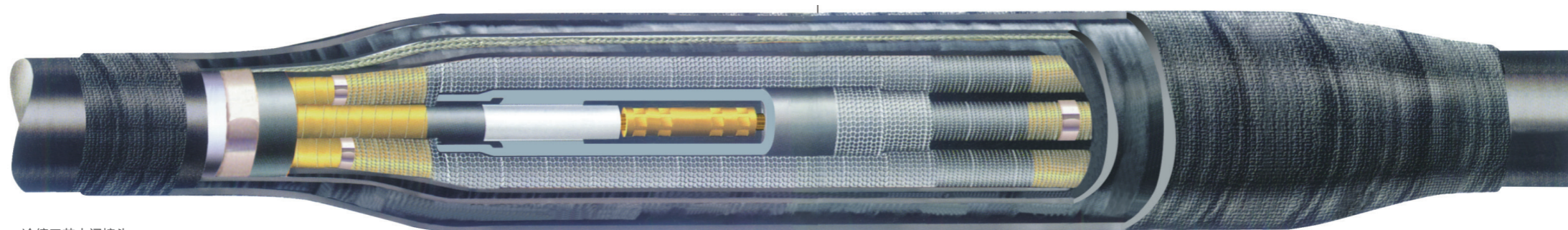

冷缩三芯中间接头  
Three-core Cold-shrink Cable Joint

### 产品特点 Product Features

- 液体硅橡胶注射成型，对电缆本体有恒定的收缩压力，与电缆同“呼吸”，局部放电量低；  
Liquid silicone rubber injection molding, providing constant shrinkage pressure on the cable—low partial discharge.
- 采用防水绝缘胶带恢复内外护层，密封可靠；  
Waterproof insulation tape for inner/outer sheath restoration with reliable sealing.
- 采用特殊“装甲带”外保护，安装便捷；  
Special "armor tape" external protection for easy installation.
- 应用于电力电缆中间连接，可用于矿井，水下等恶劣环境；  
Suitable for harsh environments (mines, underwater) for power cable connection.
- 35kV单芯接头订购请注明直通型或绝缘型；  
Specify straight-through or insulated type when ordering 35kV single-core joints.

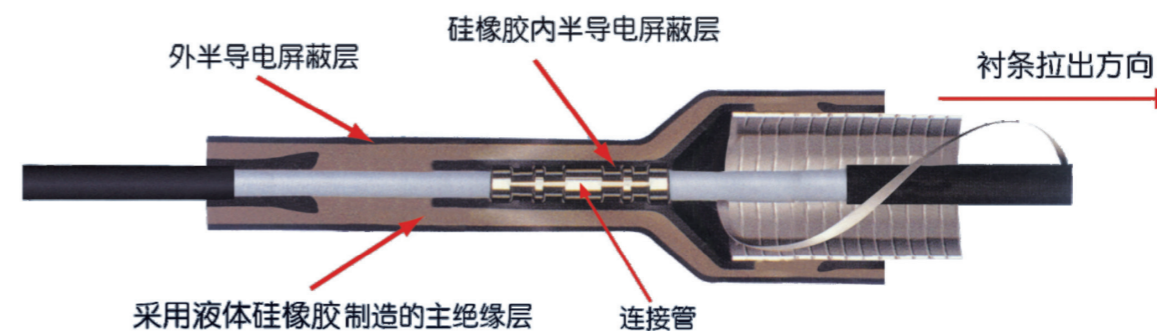

## 10~35kV预制式电缆附件 10~35kV Pre-molded Cable Accessories

### 产品符合 Complies with

- IEC60502.4《额定电压1kV到30kV挤包绝缘电力电缆及附件第四部分：电力电缆附件的试验要求》  
IEC 60502.4 Power Cables with Extruded Insulation and Accessories for Rated Voltages from 1kV to 30kV – Part 4: Test Requirements for Power Cable Accessories
- GB/T12706.4《额定电压1kV到35kV挤包绝缘电力电缆及附件第四部分：电力电缆附件的试验要求》  
GB/T 12706.4 Power Cables with Extruded Insulation and Accessories for Rated Voltages from 1kV to 35kV – Part 4: Test Requirements for Power Cable Accessories
- JB/T8503.1《额定电压6kV到35kV挤包绝缘电力电缆 冷收缩式附件 第一部分：终端》  
JB/T8503.1 Cold-shrink Accessories for Power Cables with Extruded Insulation for Rated Voltages from 6kV to 35kV – Part 1: Terminations
- T/CEC 120《额定电压35kV及以下冷缩电缆附件技术规范》  
T/CEC 120 Technical Specification for Cold-shrink Cable Accessories for Rated Voltages up to 35kV

### 适用范围 Application Scope

额定电压 Rated Voltage: 8.7/15kV 26/35kV  
 适用截面 Applicable Cross-Section: 25~630mm<sup>2</sup>  
 海拔高度 Altitude: 0~4500m  
 环境温度 Ambient Temperature: -40~+45°C  
 污秽等级 Pollution Class: e级污秽 Class E

### 产品型号 Model

三芯户外终端 WYZ3-电压-截面 Three-core Outdoor Termination: WYZ3-Voltage-Cross-Section  
 三芯户内终端 NYZ3-电压-截面 Three-core Indoor Termination: NYZ3-Voltage-Cross-Section  
 单芯户外终端 WYZ1-电压-截面 Single-core Outdoor Termination: WYZ1-Voltage-Cross-Section  
 单芯户内终端 NYZ1-电压-截面 Single-core Indoor Termination: NYZ1-Voltage-Cross-Section

### 产品特点 Product Features

- 选用特种液体硅橡胶制造，内复合专用应力锥，能有效分散终端外屏蔽断口的电场，性能优异；  
Manufactured from special liquid silicone rubber with integrated stress cone, effectively dispersing electric field at the terminal outer shield fracture—excellent performance.



预制户外终端 Prefabricated Outdoor Termination

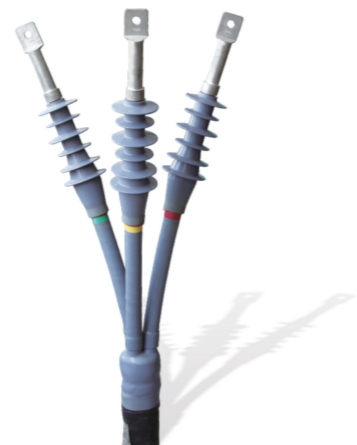

预制户内终端 Prefabricated Indoor Termination

### 产品外形图 Product Drawing Drawing

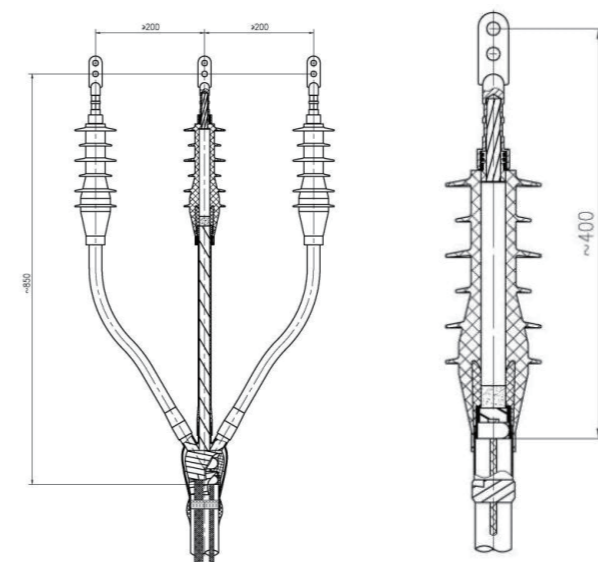

三芯预制户外  
Three-core prefabricated outdoor

单芯预制户外  
Single-core prefabricated outdoor

户外终端外形尺寸  
Outline Dimensions of Outdoor Termination

额定等级 Rated Classes	8.7/15kV	26/35kV
L <sub>1</sub> mm	~750	~1500
L <sub>2</sub> mm	~200	~400
L <sub>3</sub> mm	~400	~650

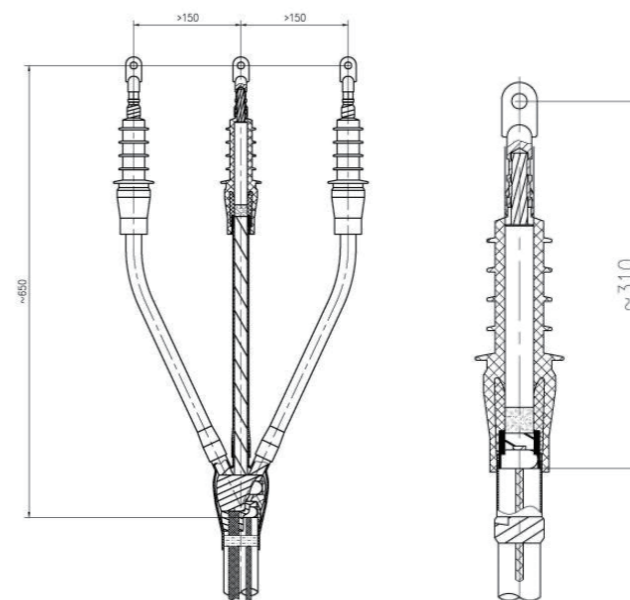

三芯预制户内  
Three-core prefabricated indoor

单芯预制户内  
Single-core prefabricated indoor

户内终端外形尺寸  
Indoor Termination Outline Dimensions

额定等级 Rated Classes	8.7/15kV	26/35kV
L <sub>1</sub> mm	~650	~1200
L <sub>2</sub> mm	~150	~300
L <sub>3</sub> mm	~310	~500

## 10~35kV热缩式电缆附件 10~35kV Heat-shrink Cable Accessories

### 产品符合 Complies with

- IEC60502.4《额定电压1kV到30kV挤包绝缘电力电缆及附件 第四部分：电力电缆附件的试验要求》  
IEC 60502.4 Power Cables with Extruded Insulation and Accessories for Rated Voltages from 1kV to 30kV – Part 4: Test Requirements for Power Cable Accessories
- GB/T12706.4《额定电压1kV到35kV挤包绝缘电力电缆及附件 第四部分：电力电缆附件的试验要求》  
GB/T 12706.4 Power Cables with Extruded Insulation and Accessories for Rated Voltages from 1kV to 35kV – Part 4: Test Requirements for Power Cable Accessories
- JB/T 7829《额定电压1kV到35kV电力电缆 热收缩式 终端》  
JB/T 7829 Heat-shrink Terminations for Power Cables with Rated Voltages from 1kV to 35kV

### 适用范围 Application Scope

额定电压 Rated Voltage: 8.7/15kV 26/35kV  
 适用截面 Applicable Cross-Section: 25~630mm<sup>2</sup>  
 海拔高度 Altitude: 0~4500m  
 环境温度 Ambient Temperature: -40~+45°C  
 污秽等级 Pollution Class: e级污秽 Class E

### 产品型号 Model

三芯户外终端 WLS3-电压-截面 Three-core Outdoor Termination: WLS3-Voltage-Cross-Section  
 三芯户内终端 NRS3-电压-截面 Three-core Indoor Termination: NRS3-Voltage-Cross-Section  
 单芯户外终端 WRS1-电压-截面 Single-core Outdoor Termination: WRS1-Voltage-Cross-Section  
 单芯户内终端 NRS1-电压-截面 Single-core Indoor Termination: NRS1-Voltage-Cross-Section  
 三芯中间接头 JRS3-电压-截面 Three-core Straight-through Joint: JRS3-Voltage-Cross-Section  
 单芯中间接头 JRS1-电压-截面 Single-core Straight-through Joint: JRS1-Voltage-Cross-Section

### 产品特点 Product Features



热缩终端运行图  
Heat-shrink Termination Service Photograph

- 产品集合了防水, 应力控制, 绝缘于一体, 具有良好的电气性能和机械性能;  
Integrates waterproofing, stress control, and insulation—excellent electrical and mechanical properties.
- 产品重量轻, 安装容易;  
Lightweight and easy to install.
- 能在各种恶劣的环境条件下长期使用运行, 适用领域广泛;  
Suitable for long-term use in various harsh environments—wide application range.

### 产品外形图 Product Drawing Drawing

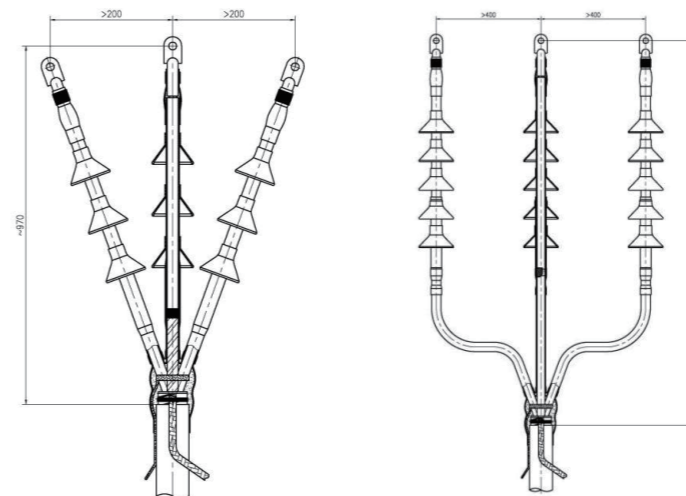

10kV三芯热缩户外10kV  
Three-core Heat-shrink Outdoor Termination

35kV三芯热缩户外10kV  
Three-core Heat-shrink Indoor Termination

户外终端外形尺寸  
Outline Dimensions of Outdoor Termination

额定等级 Rated Classes	8.7/15kV	26/35kV
L <sub>1</sub> mm	~970	~1500
L <sub>2</sub> mm	~200	~400

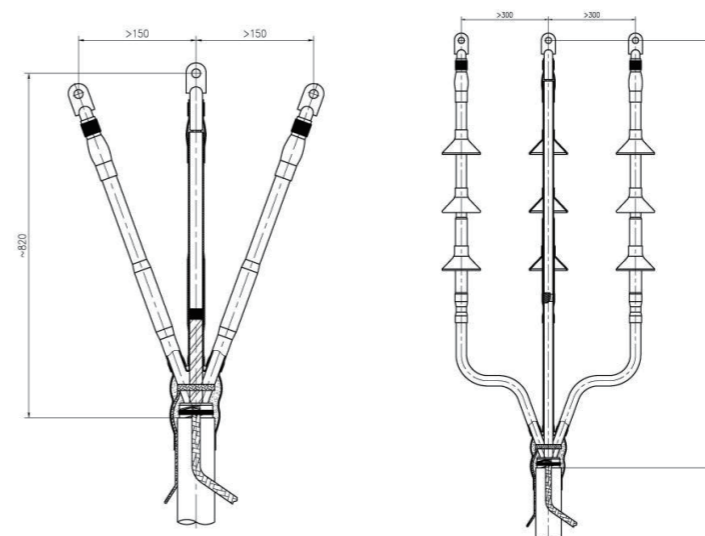

10kV三芯热缩户内10kV  
Three-core Heat-shrink Indoor Termination

35kV三芯热缩户内35kV  
Three-core Heat-shrink Indoor Termination

户内终端外形尺寸  
Outline Dimensions of Indoor Termination

电压等级 Rated Classes	8.7/15kV	26/35kV
L <sub>1</sub> mm	~970	~1500
L <sub>2</sub> mm	~200	~400

## 10~110kV放热熔接式电缆中间接头 10-110kV Exothermic Welding Cable Joint

放热熔接式电缆接头是伴随着高压超海底电缆,在世界各地广泛应用发展起来的一种特殊接头。一般称为“工厂接头”或“软接头”。

Exothermic welding cable joints, also known as "factory joints" or "soft joints", have been widely used worldwide with the development of high-voltage extra-long submarine cables.

我国陆地电力电缆线路的增长速度在全世界名列前茅。电力电缆应用的地理条件非常复杂,在沿海地区,长江流域,珠江流域等区域地下水位较高,电力电缆中间接头常年浸水运行,导致接头的故障率偏高。电缆中间接头因为进水引起的故障频发。

China's land power cable lines are growing at a leading rate globally, with complex geographical conditions. In coastal areas, Yangtze River Basin, Pearl River Basin, etc., high groundwater levels cause cable joints to operate under water year-round, leading to high failure rates.

将高压放热熔接式电缆接头应用于10-110kV陆缆可以妥善解决电缆中间接头进水的问题。

Applying high-voltage exothermic welding cable joints to 10-110kV land cables effectively solves water ingress issues.

### 产品符合 Complies with

- GB/T12706.4《额定电压1kV到35kV挤包绝缘电力电缆及附件 第四部分:电力电缆附件的试验要求》  
GB/T 12706.4 Power Cables with Extruded Insulation and Accessories for Rated Voltages from 1kV to 35kV – Part 4: Test Requirements for Power Cable Accessories
- GB/T11017.3《额定电压66kV和110kV交联聚乙烯绝缘电力电缆及其附件 第三部分:电缆附件》  
GB/T 11017.3 Power Cables with Cross-Linked Polyethylene Insulation and Accessories for Rated Voltage 66kV and 110kV – Part 3: Cable Accessories

### 适用范围 Application Scope

额定电压 Rated Voltage: 8.7/15kV, 12/20kV, 18/(20-30) kV, 26/35kV, 64/110kV  
 适用截面 Applicable Cross-Section: 35kV及以下:25~630mm<sup>2</sup>;110kV:240-1600mm<sup>2</sup>  
 海拔高度 Altitude: 0~4500m  
 环境温度 Ambient Temperature: -40~+45°C

### 产品型号 Model

三芯中间接头 JFRRJ3-电压-截面 Three-core Straight-through Joint: JFRRJ3-Voltage-Cross-Section  
 单芯中间接头 JFRRJ1-电压-截面 Single-core Straight-through Joint: JFRRJ1-Voltage-Cross-Section



110kV熔接式中间接头  
110kV Exothermic Welding Cable Joint



### 产品特点 Product Features

永锦制造的10~35kV放热熔接式电缆中间接头的线芯连接方式可靠性高。

The 10-35 kV exothermic welding cable joints manufactured by Yongjin feature highly reliable core connection.

永锦放热熔接式电缆中间接头与交联电缆的设计理念是基本相同的,放热熔接式电缆中间接头的结构与电缆完全相同。

Designed in line with the fundamental concept of XLPE cables, Yongjin exothermic welding cable joints feature a structure fully consistent with that of the cable itself.

#### 特点如下 Features:

- 1.利用专用石墨模具、特制焊药对铜芯电缆线芯进行放热熔接;  
Copper cable conductors are joined by exothermic welding using dedicated graphite molds and special welding flux.
- 2.因放热熔接属于分子焊接,线芯之间铜导体在高温下融为一体,不会松弛老化、能承受偶发的冲击电流;  
As exothermic welding is a form of molecular bonding, copper conductors fuse together metallurgically at high temperature, eliminating loosening or aging and enabling it to withstand occasional impulse currents.
- 3.用与制造电缆相近的材料来恢复电缆本体,恢复过程是一个加热熔融交联结合的过程,相关半导体材料,绝缘材料通过加热硫化与电缆本体材料相熔,成为一个整体。  
Cable integrity is restored using materials similar to those in cable production, through heat melting, cross-linking and bonding. Semi-conductive and insulation materials are vulcanized and fused with the original cable structure to form an integral unit.
- 4.内屏蔽层、绝缘层均交联熔融结合,无活动界面,具有可靠的电气性能;  
The inner shielding layer and insulation layer are cross-linked and fusion-bonded without movable interfaces, ensuring stable and reliable electrical performance.
- 5.实现了恢复电缆本体结构的目的,其电场分布很均匀,与电缆本体的电场分布基本相同;可提高电力电缆的运行寿命。  
The original cable structure is fully restored, resulting in uniform electric field distribution consistent with that of the cable itself, which effectively extends the service life of the power cable.

### 产品外形图 Product Outline Drawing



35kV熔接式三芯中间接头  
35kV Exothermic Welding Three-core Cable Joint



10kV熔接式三芯中间接头  
10kV Exothermic Welding Three-core Cable Joint

## 欧式电缆可分离式连接器 European-Type Separable Cable Connector

### 产品符合 Complies with

- EN50180《充液变压器用1kV至36kV, 250A至1250A的套管》  
EN 50180: Bushes for fluid-filled transformers for rated voltages from 1kV up to and including 36kV and rated currents from 250A to 1250A.
- EN50181《不包括充液变压器在内的设备用1kV至36kV, 250A至1250A的插入式套管》  
EN 50181: Plug-in bushings for equipment other than fluid-filled transformers for rated voltages from 1kV up to and including 36kV and rated currents from 250A to 1250A.
- IEC60502.4《额定电压1kV到30kV挤塑绝缘电力电缆及附件 第四部分: 电力电缆附件的试验要求》  
IEC 60502-4: Power cables with extruded insulation and their accessories for rated voltages from 1kV up to 30kV – Part 4: Test requirements for power cable accessories
- GB/T12706.4《额定电压1kV到35kV挤塑绝缘电力电缆及附件 第四部分: 电力电缆附件的试验要求》  
GB/T 12706.4: Extruded insulation power cables and their accessories for rated voltages from 1kV up to 35kV – Part 4: Test requirements for power cable accessories.
- GB311.1《绝缘配合 第一部分: 定义、原则和规则》  
GB 311.1: Insulation coordination – Part 1: Definitions, principles and rules
- GB11032《交流无间隙金属氧化物避雷器》  
GB 11032: AC gapless metal oxide surge arresters



### 产品简介 Product Introduction

欧式电力电缆可分离连接器, 可广泛用于SF6环网柜, 紧凑型箱式变电站, 电缆分支箱等电器设备;  
European-type separable connectors for power cables are widely used in electrical equipment such as SF6 gas-insulated ring main units, compact box-type substations and cable distribution boxes.

#### 技术参数 Technical Parameters:

项目Item	15kV	24kV	35kV
额定电压 Rated Voltage	8.7/15kV	12/20kV、18/20kV	26/35kV
工频耐压 Power Frequency Withstand Voltage	45 kV	55kV/5min	117kV/5min
直流耐压 DC Withstand Voltage 15min	53 kV	78 kV	104kV
雷电冲击电压 Lightning Impulse Voltage 1.5/50μs	95 kV	125 kV	200kV
局部放电 Magnitude of PD	15 kV, 小于10Pc	20 kV, 小于10Pc	45 kV, 小于10Pc
项目Item	250A	630A	1250A
额定电压 Rated Voltage	16kA、1S	30kA、2S	31.5kA、2S
工频耐压 Power Frequency Withstand Voltage	40kA	80kV	105kA

## (欧式) 屏蔽型前接头、后接头、避雷器 European-type Shielded Front Connector, Rear Connector, and Surge Arrester

### 产品符合 Complies with

- EN50180《充液变压器用1kV至36kV, 250A至1250A的套管》  
EN 50180: Bushes for fluid-filled transformers for rated voltages from 1kV up to and including 36kV and rated currents from 250A to 1250A
- EN50181《不包括充液变压器在内的设备用1kV至36kV, 250A至1250A的插入式套管》  
EN 50181: Plug-in bushings for equipment other than fluid-filled transformers for rated voltages from 1kV up to and including 36kV and rated currents from 250A to 1250A
- IEC60502.4《额定电压1kV到30kV挤塑绝缘电力电缆及附件 第四部分: 电力电缆附件的试验要求》  
IEC 60502-4: Power cables with extruded insulation and their accessories for rated voltages from 1kV up to 30kV – Part 4: Test requirements for power cable accessories
- GB/T12706.4《额定电压1kV到35kV挤塑绝缘电力电缆及附件 第四部分: 电力电缆附件的试验要求》  
GB/T 12706.4: Extruded insulation power cables and their accessories for rated voltages from 1kV up to 35kV – Part 4: Test requirements for power cable accessories

### 产品特点 Product Features

- 三层复合可触摸型前/后电缆接头, 可以通过前后连接的方式形成多路多形式的电缆分支;  
Three-layer composite touch-safe front/rear cable connectors enable multi-way and multi-form cable branching through front-to-back connection.
- 可安装短路故障指示器或带电指示器, 实现故障定位或线路带电状态指示。也满足核相要求;  
Short-circuit fault indicators or live-line indicators can be installed to realize fault location or line live status indication, and the product also meets phase verification requirements.



后接示避雷器  
Rear-connected Surge Arrester

### 电压等级 Voltage Classes

8.7/15kV、12/20kV、18/ (20-30) kV、26/35kV

### 产品型号 Product Model

630A: SQJ-615 (前接头Front Connector)  
SHJ-615 (后接头Rear Connector)  
HB-17/50 (避雷器Arrester)



屏蔽型后接头 Shielded Rear Connector



屏蔽型前接头 Shielded Front Connector

II型Type

**(欧式)直通接头(可触摸型)**  
European-type Straight-Through Connector (Touch-Safe)

**产品型号** Product Model

250A:RTJ-224

**电压等级** Voltage Classes

8.7/15kV, 12/20kV

**产品特点** Product Features

- 1.应用符合欧式标准套管的环网柜, 变压器高压引出线电缆的连接, 可垂直安装;  
Suitable for connecting high-voltage outgoing cables of transformers and ring main units fitted with European-standard bushings; vertical installation is applicable.
- 2.可安装短路故障指示器或带电指示器, 实现故障定位或线路带电状态指示。也满足核相要求;  
Can be equipped with short-circuit fault indicators or live-line indicators to realize fault location and line live status indication. It also meets phase verification requirements.



**(欧式)肘通接头(可触摸型)**  
European-type Elbow Connector (Touch Safe)

**产品型号** Product Model

250A:RTJ-215

**电压等级** Voltage Classes

8.7/15kV, 12/20kV

**产品特点** Product Features

- 1.应用符合欧式DIN7636 250A标准套管的环网柜, 变压器高压引出线电缆的连接, 可水平安装;  
Suitable for connecting high voltage outgoing cables of transformers and ring main units equipped with bushings complying with European standard DIN 7636 (250 A); horizontal installation is applicable.
- 2.可安装短路故障指示器或带电指示器, 实现故障定位或线路带电状态指示。也满足核相要求;  
Can be fitted with short circuit fault indicators or live line indicators for fault location and live line status indication. It also meets phase verification requirements.



**(美式)T型电缆终端**  
American-type T shaped Cable Termination

**适用范围** Application Scope

适用于中压电缆与各种配电设备的连接。美式箱变, 美式环网柜首选  
Suitable for connecting medium-voltage cables to various distribution equipment. Ideal for American-type pad-mounted transformers and American-type ring main units.

**电压等级** Voltage Classes

8.7/15kV, 12/20kV

**产品特点** Product Features

- 1.产品符合IEEE386及IEC60502.4标准;  
The product complies with IEEE 386 and IEC 60502-4 standards.
- 2.产品全屏蔽, 可触摸。应力锥, 绝缘料与外半导体料三层材料复合;  
Fully shielded and touch-safe design. Three-layer composite structure consisting of stress cone, insulation material and outer semi-conductive material.
- 3.电容测试点, 便于确认线路是否带电;  
Equipped with a capacitive test point for easy verification of line live status.



**(美式)肘型接头**  
American-type Elbow Connector

**产品型号** Product Model

8.7/15kV (200A)

**产品特点** Product Features

- 1.外半导体层与绝缘层紧密贴合;  
The outer semiconducting layer is tightly bonded to the insulation layer.
- 2.优质的EPDM橡胶(或硅橡胶);  
High-quality EPDM rubber (or silicone rubber).
- 3.电应力控制锥;  
Integrated electrical stress control cone.
- 4.有可检测回路工作状态的电容测试点  
Equipped with a capacitive test point for monitoring the operating status of the circuit.



## 美式电缆分接箱 American-type Cable Distribution Cabinet

### 概述 Overview

DFW-12kV美式电缆分接箱基本组合方式是母排接板固定在电缆分支箱内，母排接板出口接T型电缆接头，T-II型电缆接头或肘型电缆插头。产品性能参数与欧式电缆分接箱相同。

The basic configuration of the DFW-12kV American-type cable distribution cabinet features a busbar mounting plate fixed inside the cabinet. The outlets of the busbar mounting plate are connected to T-type cable connectors, T-II type cable connectors, or elbow cable plugs. The performance parameters of this product are identical to those of European-type cable distribution cabinets.



美式电缆分接箱  
American-type Cable Distribution Cabinet

### 型号说明 Model Explanation

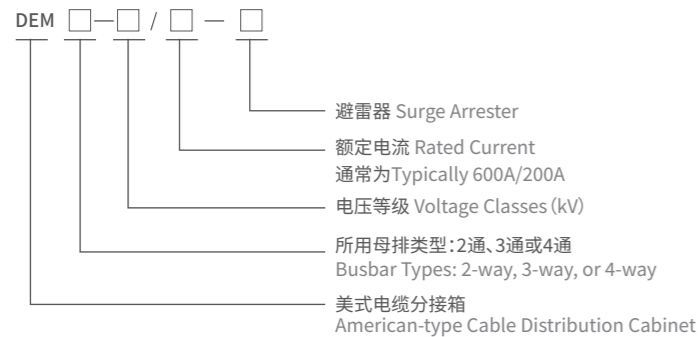

美式电缆分接箱选型表 American-type Cable Distribution Cabinet Selection Table

分支回路数 Number of Branch Circuits	方案 Configuration	分支回路数 Number of Branch Circuits	方案 Configuration
三回路 3-Circuit		四回路+P 4-Circuit+P	
二回路+P 2-Circuit + P		五回路+P 5-Circuit + P	
四回路 4-Circuit		七回路 7-Circuit	
五回路 5-Circuit		八回路 8-Circuit	



## 欧式电缆分接箱 European-style Cable Distribution Boxes

### 结构特点 Structural Features

1. 可根据现场条件组合成多种回路形式  
Configurable into multiple circuit layouts based on on-site conditions.
2. 箱体采用优质不锈钢加工，表面经喷漆处理  
Cabinet constructed from high-quality stainless steel with spray-painted finish.
3. 箱体内存分离连接器（电缆终端）屏蔽型与非屏蔽型可选  
Optional shielded or unshielded separable connectors (cable terminations) inside the cabinet.
4. 可带避雷器保护  
Available with surge arrester protection.
5. 可配装收带电显示器及故障指示器  
Compatible with live-line indicators and fault indicators.



### 型号说明 Model Explanation

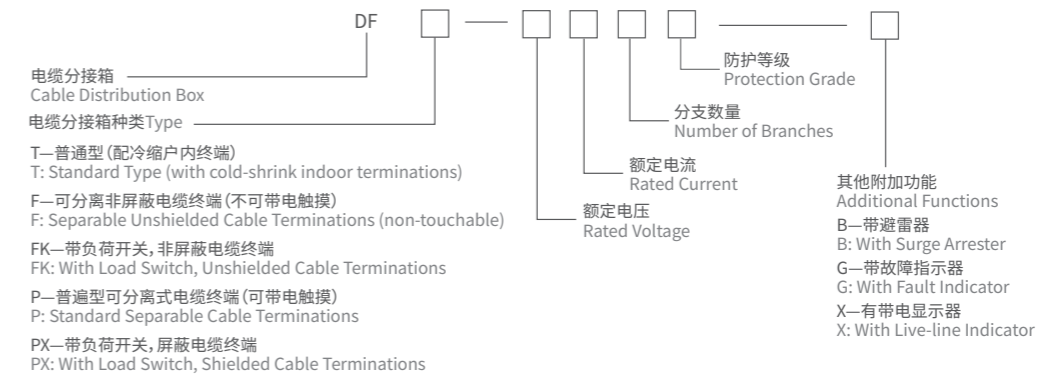

美式电缆分接箱选型表 American-type Cable Distribution Cabinet Selection Table

分支回路数 Number of Branch Circuits	型号 Model	方案 Configuration
三分支 3-branch	DFP3-12/630	每相有两只欧式前接头、一只欧式后接头 2 European-style front connectors + 1 rear connector per phase
三分支带避雷器 3-branch with Arrester	DFPB3-12/630	每相有两只欧式前接头、一只后接头，一只全绝缘氧化锌避雷器通过穿墙 2 front connectors + 1 rear connector + 1 fully insulated ZnO arrester (via wall bushing) per phase
四分支 4-branch	DFP4-12/630	每相有两只欧式前接头、两只后接头和通过穿墙套管连接组成 2 front connectors + 2 rear connectors (connected via wall bushings) per phase
五分支带避雷器 5-branch with Arrester	DFPB5-12/630	每相由两只前接头，3支欧式后接头、一只避雷器通过穿墙器 2 front connectors + 3 rear connectors + 1 arrester (via wall bushing) per phase



### 35-220kV电缆接地箱 35-220kV Cable Earthing Boxes

#### 产品特点 Product Features

- 1、接地箱外壳及连接螺栓全部采用不锈钢材料，耐腐蚀，性能优良  
Shell and connecting bolts made of stainless steel, offering excellent corrosion resistance.
- 2、导电连接全部采用螺栓压紧结构，安装方便，便于进行预防性试验  
Bolted compression structure for conductive connections, facilitating installation and preventive testing.
- 3、内部保护器选用优质的硅橡胶复合氧化锌保护器  
Internal protectors adopt high-quality silicone rubber composite zinc oxide arresters.
- 4、导电连接件全部镀锡处理，导电性能可靠，绝缘支撑件均采取防潮处理  
Tin-plated conductive connectors ensure reliable conductivity; insulation supports are moisture-proof treated.

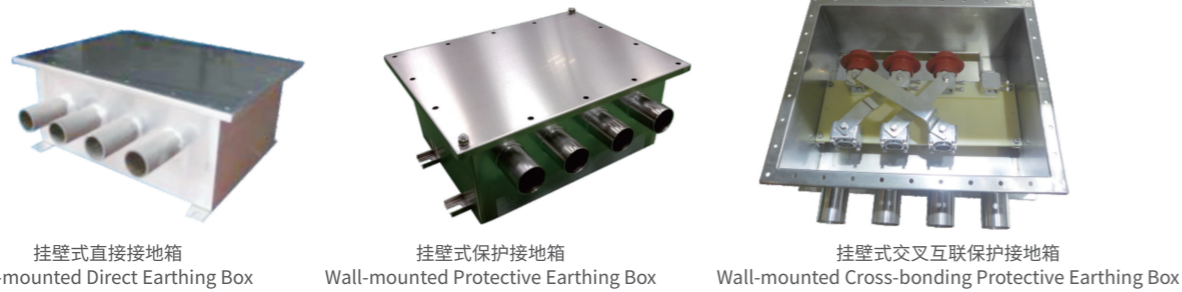

#### 35-220kV单芯高压电流护层保护器产品特点 35-220kV Single-core High-voltage Current Sheath Protectors Product Features

- 优异的保护特性，有效限制电缆金属屏蔽层(或金属护套)感应过电压和故障过电压；  
Excellent protection performance, effectively limiting induced overvoltage and fault overvoltage on cable metal shielding layers (or sheaths).
- 优良的电压-电流特性曲线，通流能力大，保护曲线平坦；  
Superior voltage-current characteristic curve with large current-carrying capacity and flat protection response.
- 硅橡胶外套采用一次成型工艺，密封性能好，安全防爆，免维护；  
One-piece silicone rubber housing with reliable sealing, explosion-proof, and maintenance-free design.

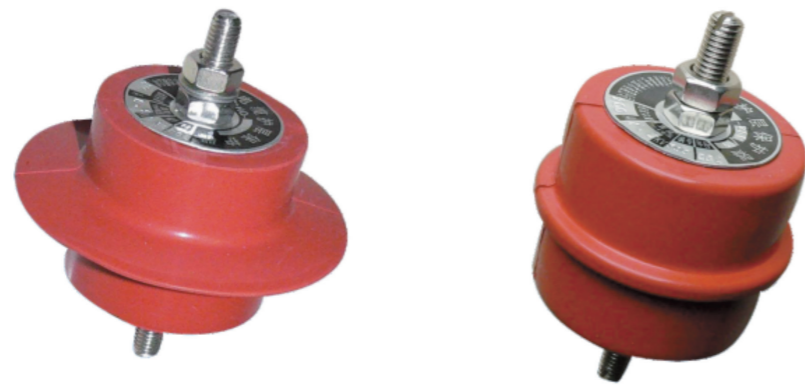

电缆护层保护器 Cable Sheath Protector (110-220kV、35kV)

#### 产品性能指标 Performance Indicators

产品型号 Product Model	适用电缆系统电压 Applicable Cable System Voltage /kV	额定电压 有效值 Rated Voltage (RMS) /kV	持续运行电压(有效值) Continuous Operating Voltage (RMS) /kV	8/20us标称放电电流 Nominal Discharge Current /kA	直流参考电压DC Reference Voltage U <sub>1mA</sub> /kV	0.75U <sub>1mA</sub> 下的泄漏电流 Leakage Current at 0.75U <sub>1mA</sub> /μA	标称放电电流下的残压 Residual Voltage at Nominal Discharge Current /kV	2000us方波电流(幅值) 2000μs Square Wave Current (Peak) /A	4/10冲击耐受 4/10 Impulse Withstand /kA
BHQ-7/200	35	2.8	2.24	5	≥4.0	≤30	≤7	200	65
BHQ-7/400	110、220	2.8	2.24	10	≥4.0	≤30	≤7	400	100
BHQ-10/400	110、220	3.6	2.64	10	≥5.8	≤30	≤10	400	100
BHQ-10/600	110、220	4.0	3.20	10	≥5.8	≤30	≤10	600	100

#### 接地箱产品选型表 Earthing Box Selection Table

	产品名称Product Name	挂壁式 Wall-mounted	直立式 Floor-standing
智能接地箱 Intelligent Earthing Box	三相保护接地箱(直立式&挂壁式) Three-phase Protective Earthing Box	ZNHBJDX-I(A.B.C)	ZL-ZNHBJDX-I(A.B.C)
	三相直接接地箱(直立式&挂壁式) Three-phase Direct Earthing Box	ZNJDX-I(A.B.C)	ZL-ZNJDX-I(A.B.C)
	三相交叉互联接地箱(直立式&挂壁式) Three-phase Cross-bonded Earthing Box	ZNBJDX-II(A.B.C)	ZL-ZNBJDX-II(A.B.C)
普通接地箱 Standard Earthing Box	三相保护接地箱(直立式&挂壁式) Three-phase Protective Earthing Box	HBJDX-I(A.B.C)	ZL-HBJDX-I(A.B.C)
	三相直接接地箱(直立式&挂壁式) Three-phase Direct Earthing Box	JDX-I(A.B.C)	ZL-JDX-I(A.B.C)
	三相交叉互联接地箱(直立式&挂壁式) Three-phase Cross-bonded Earthing Box	JBjDX-II(A.B.C)	ZL-JBjDX-II(A.B.C)
	单相保护接地箱(挂壁式) Single-phase Protective Earthing Box	HBJDX-II(A.B.C)	
	单相直接接地箱(挂壁式) Single-phase Direct Earthing Box	JDX-II(A.B.C)	
	六相直接接地箱(挂壁式) Six-phase Direct Earthing Box	JDX-III(A.B.C)	
	直接保护二合一(挂壁式) Integrated Direct & Protective Earthing Box	EHyJDX-III(A.B.C)	

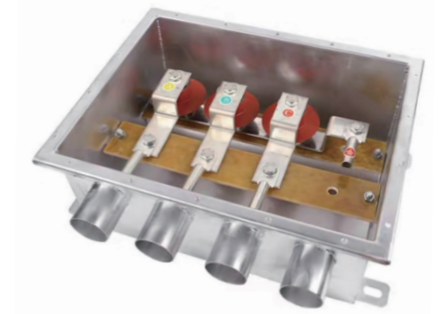

注:A.35kV B.110kV C.220kV

## 10-220kV中间接头防水、防爆壳 10-220kV Joint Waterproof and Explosion-proof Enclosures

### 产品简介 Product Introduction

高压电缆中间接头防火、防爆装置安装于中间接头外起防护作用，避免引起火灾或造成二次事故。该装置参照电缆的设计规范，在内部温度达到170°C的情况下，可以自启动进行灭火或降温，彻底防止因电缆温度过热引起的连锁电缆火灾事故。

High-voltage cable joint fire and explosion protection enclosures are installed externally to prevent fires and secondary accidents. Designed in compliance with cable design standards, the enclosure automatically activates fire extinguishing or cooling when internal temperature reaches 170°C, completely avoiding chain cable fires caused by overheating.

本系列产品是根据国家电网公司十八项电网重大反事故措施(2018年修订版)要求设计制造的产品。

This series is manufactured in accordance with the 18 Major Anti-accident Measures for Power Grids (2018 Revised Edition) by the State Grid Corporation of China.

### 产品特点 Product Features

1. 外壳主体材质采用无磁性合金，加工工艺采用模压式一次性成型，外形美观。  
Main shell made of non-magnetic alloy, one-piece molding via compression molding for an aesthetic appearance.
2. 采用上下两部分组成，安装简便，可重复拆装使用。  
Two-piece split design for easy and reusable installation.
3. 耐压性能强：壳体可承受来自内部或外部都超强冲击  
High pressure resistance: capable of withstanding extreme internal and external impacts.
4. 壳体设有泄能泄压孔，当电缆中间接头发生击穿爆炸时，可释放能量。  
Equipped with pressure relief holes to release energy in case of joint breakdown or explosion.
5. 配置的自动灭火装置能有效地阻止火势及有毒烟气蔓延。  
Integrated automatic fire extinguishing device effectively prevents fire and toxic smoke spread.
6. 具有防火、防爆、防水、防尘、抗震等功能。  
Multi-functional: fireproof, explosion-proof, waterproof, dustproof, and shockproof.
7. 外壳环保可回收利用：使用寿命长，综合效益好。  
Environmentally friendly and recyclable shell with long service life and high comprehensive benefits.



110kV铝镁合金防爆壳  
110kV Aluminum-Magnesium Alloy Explosion-Proof Box



35kV铝镁合金防爆盒  
35kV Aluminum-Magnesium Alloy Explosion-Proof Box



10kV铝镁合金防爆盒  
10kV Aluminum-Magnesium Alloy Explosion-Proof Box

### 结构特点 Structure Features

1. 电缆隧道内不明原因产生火情，该装置可以对中间接头进行防护。  
Protects intermediate joints from fires of unknown origin in cable tunnels.
2. 特殊情况下一旦电缆中间接头发生故障(击穿、燃爆)，可以有效减缓冲击力，对周边其它电力设施，人员起到有效地保护。  
Effectively mitigates impact force in case of joint failures (breakdown, explosion), safeguarding surrounding power facilities and personnel.

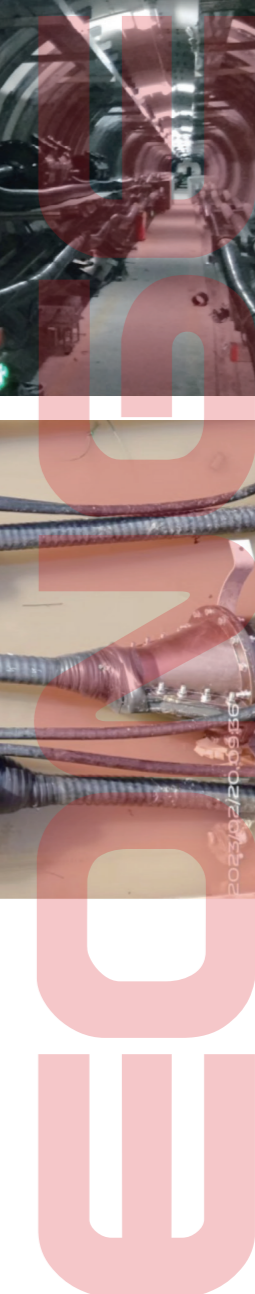
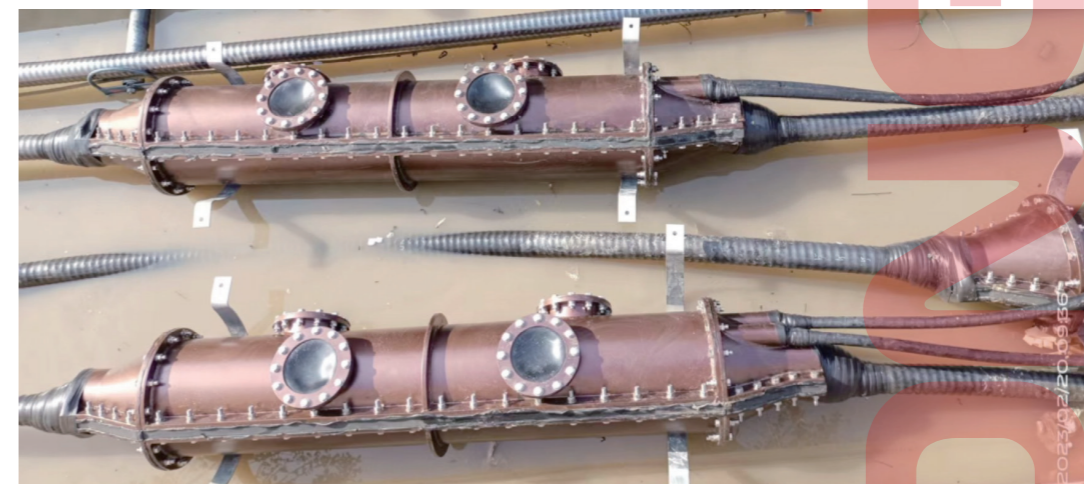

## FJA系列1kV树脂浇注电缆接头 FJA Series 1 kV Resin Cast Cable Joints

### 产品特点

### Product Features

- 适用于低压电力电缆, 通讯电缆及信号电缆  
Suitable for low-voltage power cables, communication cables, and signal cables.
- 采用聚氨酯冷浇注技术, 安装简便, 快捷  
Adopts polyurethane cold-casting technology, enabling simple and quick installation.
- 优良的防水密封性能和机械防护性能  
Excellent waterproof sealing performance and mechanical protection properties.
- 电气性能稳定可靠  
Stable and reliable electrical performance.

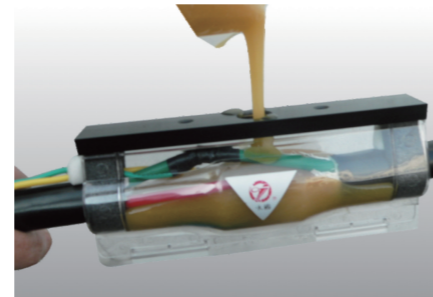

直通型接头选型表 Selection Table for Straight-Through Connectors

型号 Mode	参考电缆外径 Reference Cable Outer Diameter (mm)	参考最大电缆截面范围 Reference Maximum Cable Cross-section Range (mm <sup>2</sup> )	
		铠装电缆 Armoured Cable	无铠装电缆 Unarmoured Cable
JA-1	8-26	3×10 4×10	3×16 4×16
JA-2	14-32	3×16 4×16	3×50 4×25
JA-3	23-39	3×50 4×35	3×50 4×50
JA-4	28-50	3×95 4×70	3×95 4×95
JA-5	33-60	3×150 4×120	3×185 4×150
JA-6	45-77	3×300 4×240	3×300 4×300
JA-7	45-90	3×400 4×40	3×400 4×400

FJA分支型选型表 FJA Branch Type Selection Table

型号 Mode	参考电缆外径 Reference Cable Outer Diameter (mm)		参考最大电缆截面范围 Reference Maximum Cable Cross-section Range (mm <sup>2</sup> )	
	主回 Main	分支 Branch	主回电缆 Main Cable	分支电缆 Branch Cable
JA-1			2.5-3.5	2.5-3.5
JA-2	15	15	1-5芯Cores×1.5-6	1-5芯Cores×1.5-6
JA-3	22	21	1-5芯Cores×6-10	1-5芯Cores×6-10
JA-4	29	22	1-5芯Cores×16-25	1-5芯Cores×16-25
JA-5	35	25	1-5芯Cores×37-70	1-5芯Cores×37-70
JA-6	50	30	1-5芯Cores×90-150	1-5芯Cores×90-150



分支及直通接头基本性能  
Basic Performance of Branch and Straight-Through Connectors

项目 Item	检测结果 Test Result
工频电压试验 Power Frequency Voltage Test	4kV, 1min
工频电压试验 Power Frequency Voltage Test	2.4kV, 4h
浸水试验 Water Immersion Test	将样品浸没于水中 30天水位高于中心1米 Sample immersed in water for 30 days, water level 1 m above center
浸水后工频电压试验 Power Frequency Voltage Test After Water Immersion	4kV, 1min未击穿 no breakdown

## 高压电缆线路故障快速抢修接头(主网电缆故障快速恢复接头) HV Cable Fault Emergency Repair Joints(Main Grid Cable Fault Quick Recovery Joints)

本产品被国网列入高压电缆专业精益化综合管理平台改造项目, 高压电缆新技术推广应用项目。  
This product has been included in the State Grid Corporation of China's (SGCC) projects: High-voltage Cable Professional Lean Comprehensive Management Platform Transformation, and High-voltage Cable New Technology Promotion & Application.

### 产品符合

### Complies with

- IEC60840《额定电压30kV(Um=36kV)以上至150kV(Um=170kV)挤包绝缘电缆及其附件》  
IEC 60840 Extruded Insulated Power Cables with Accessories for Rated Voltages above 30kV (Um = 36kV) up to 150kV (Um = 170kV)
- IEC62067《额定电压150kV(Um=170kV)以上至500kV(Um=550kV)挤包绝缘电缆及其附件》  
IEC 62067 Extruded Insulated Power Cables with Accessories for Rated Voltages above 150kV (Um = 170kV) up to 500kV (Um = 550kV)
- GB/T18890.3《额定电压220kV交联聚乙烯绝缘电力电缆及其附件 第三部分: 电缆附件》  
GB/T 18890.3 Power Cables with Cross-Linked Polyethylene Insulation and Their Accessories for Rated Voltage 220kV - Part 3: Cable Accessories
- GB/T11017.3《额定电压66kV和110kV交联聚乙烯绝缘电力电缆及其附件 第三部分: 电缆附件》  
GB/T 11017.3 Power Cables with Cross-Linked Polyethylene Insulation and Accessories for Rated Voltage 66kV and 110kV - Part 3: Cable Accessories

### 适用范围

### Application Scope

额定电压 Rated Voltage: 64/110kV 127/220kV  
适用截面 Applicable Cross-Section: 240-1600mm<sup>2</sup> 400-2500mm<sup>2</sup>

### 产品型号

### Product Model

YJJK

### 技术特点

### Technical Features

1. 经过电场仿真验证, 满足设计要求;  
Electric field simulation verified, meeting design specifications.
2. 电气性能优异, 局放指标优于国家标准;  
Excellent electrical performance with partial discharge indicators exceeding national standards.
3. 性能稳定, 经过全套型式试验;  
Stable performance, passing a full set of type tests.
4. 安装时间迅速, 110kV产品可以2.5小时内完成; 220kV产品可以4小时内完成  
Rapid installation: 110kV products can be completed within 2.5 hours; 220kV products within 4 hours.
5. 密封性能优异, 长期带点运行;  
Superior sealing performance for long-term live operation.



110kV电缆快速恢复接头型式试验  
Type Test for 110kV Cable Quick Recovery Joints

### 产品外形图

### Product Drawing Drawing

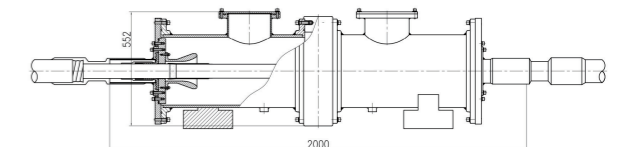
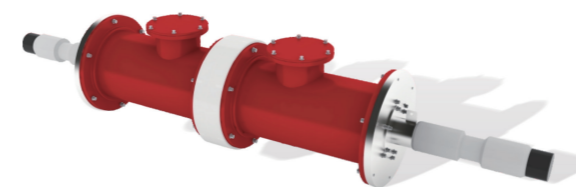

110kV电缆快速恢复油浸式接头——B型验 Type B 110kV Cable Quick Recovery Oil-Immersed Joint

产品外形图

Product Drawing Drawing

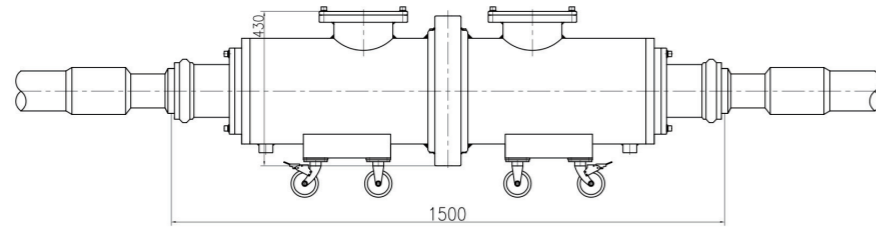

110kV电缆加长型快速恢复接头 110kV Cable Extended Quick Recovery Joint

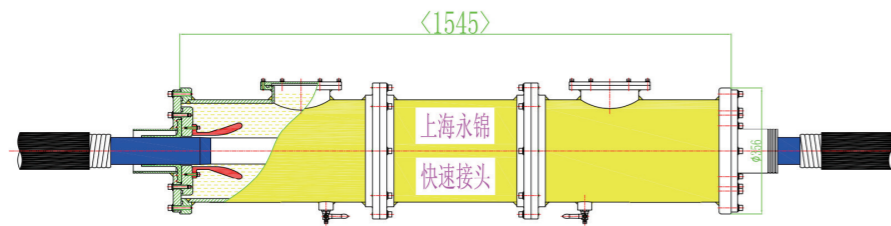
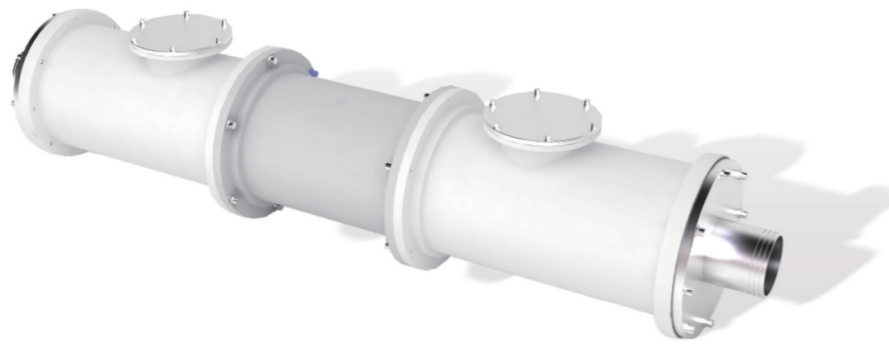

220kV电缆干式快速恢复接头 220kV Cable Dry-type Quick Recovery Joint

产品外形图

Product Drawing Drawing



220kV电缆干式快速恢复接头  
220kV Cable Dry-type Quick Recovery Joint

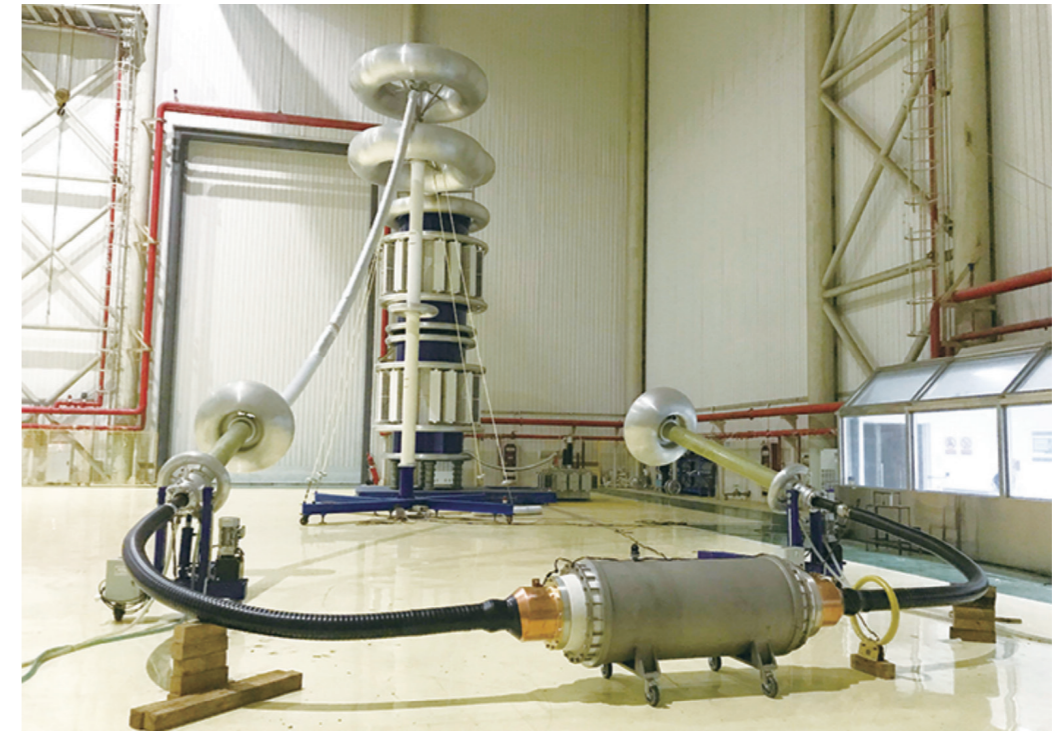

220kV电缆干式快速恢复接头型式试验  
220kV Cable Dry-type Quick Recovery Joint Type Test

## 铁路电缆附件 Railway Cable Accessories

### 产品简介 Product Introduction

电气化铁路电缆附件主要是指额定电压27.5kV电缆附件, 用于27.5kV电压等级的电气化铁路中的输变电线路。其冷缩式、预制式产品以高弹性优质硅橡胶为材料, 采用进口硅橡胶注射机设备硫化成型; 内锥插拔式终端产品不需要任何绝缘浇注剂, 结构紧凑, 检修简便。产品均有性能优良, 安装方便等特点。

Railway cable accessories mainly refer to products rated at 27.5kV, designed for power transmission and distribution lines in 27.5kV class electrified railways.

- Cold-shrink and pre-molded products are made of high-elasticity premium silicone rubber, vulcanized and formed using imported silicone rubber injection molding equipment.
- Inner cone plug-in terminations require no insulating casting agent, featuring a compact structure and easy maintenance.
- All products boast excellent performance and convenient installation.

注: 也有一些铁路系统电气设备使用8.7/15kV、12/20kV电压等级电缆附件。

Note: Some railway system electrical equipment also uses 8.7/15kV and 12/20kV class cable accessories.



### 适用范围 Application Scope

1. 电气化铁路 冷缩式、预制式终端 适用于额定电压27.5kV及以下, 标称截面: 50~630mm<sup>2</sup> 单芯交联聚乙烯绝缘及橡胶电力电缆;  
Cold-shrink and pre-molded terminations for electrified railways: Suitable for single-core XLPE insulation and rubber power cables with rated voltage ≤27.5kV and nominal cross-section: 50~630mm<sup>2</sup>.
2. 电气化铁路 冷缩式直通、绝缘接头 适用于额定电压27.5kV及以下, 标称截面50~630mm<sup>2</sup>单芯交联聚乙烯绝缘及橡胶电力电缆;  
Cold-shrink straight-through and insulated joints for electrified railways: Suitable for single-core XLPE insulation and rubber power cables with rated voltage ≤27.5kV and nominal cross-section: 50~630mm<sup>2</sup>.
3. 电气化铁路 内锥插拔式终端 适用于额定电压27.5kV及以下, 标称截面50~630mm<sup>2</sup>单芯交联聚乙烯绝缘及橡胶电力电缆;  
Inner cone plug-in terminations for electrified railways: Suitable for single-core XLPE insulation and rubber power cables with rated voltage ≤27.5kV and nominal cross-section: 50~630mm<sup>2</sup>.

### 主要电气性能 Key Electrical Performance

检测项目 Test Item	8.7/15kV	12/20kV	27.5/48kV
室温局放试验 Room Temp PD Test	15kV, <10pC	20kV, <10pC	48kV, <10pC
工频耐压试验 Power Frequency Withstand Voltage Test	39kV, 5min 不击穿、不闪络	54kV, 5min 不击穿、不闪络	124kV, 5min 不击穿、不闪络
负荷循环试验60周期 Load Cycle Test (60 cycles)	在23kV导体温度 (95~100°C)下 共经受60个循环	在30kV导体温度 (95~100°C)下 共经受60个循环	在69kV导体温度 (95~100°C)下 共经受60个循环
冲击电压试验 Impulse Voltage Test	95kV, 正负各10次 不击穿、不闪络	125kV, 正负各10次 不击穿、不闪络	250kV, 正负各10次 不击穿、不闪络
高温局放试验 High Temp PD Test	15kV, <10pC	20kV, <10pC	48kV, <10pC
工频耐压试验 Power Frequency Withstand Voltage Test	23kV, 15min 不击穿、不闪络	54kV, 5min 不击穿、不闪络	124kV, 5min 不击穿、不闪络
热稳定试验 Thermal Stability Test	24kA, 2S, 2次	24kA, 2S, 2次	24kA, 2S, 2次
动稳定试验 Dynamic Stability Test	85kA, ≥20ms	85kA, ≥20ms	85kA, ≥20ms
潮湿试验 (户内) Humidity Test (Indoor)	1.25U <sub>0</sub> , 300h	1.25U <sub>0</sub> , 300h	1.25U <sub>0</sub> , 300h
盐雾试验 (户外) Salt Spray Test (Outdoor)	1.25U <sub>0</sub> , 1000h	1.25U <sub>0</sub> , 1000h	1.25U <sub>0</sub> , 1000h

## 铁路用电缆终端 Railway Cable Terminal

### 产品符合 Complies with

- GB/T28427《电气化铁路27.5kV单相交流交联聚乙烯绝缘电缆及附件》  
GB/T 28427 27.5kV Single-phase AC Cross-linked Polyethylene (XLPE) Insulated Cables and Accessories for Electrified Railways

### 适用范围 Application Scope

- 额定电压 Rated Voltage: 27.5kV;
- 适用截面 Applicable Cross-Section: 50~630mm<sup>2</sup>;
- 海拔高度 Altitude: 0~4500m
- 环境温度 Ambient Temp: -40~+45°C
- 污秽等级 Pollution Class: e级污秽 Class E

### 产品外形图 Product Outline Drawing

- 冷缩式 Cold-shrink:  
单芯户外终端 WTLS-1-电压-截面  
Single-core Outdoor Termination: WTLS-1-Voltage-Cross-Section
- 单芯户内终端 NTLS1-电压-截面  
Single-core Indoor Termination: NTLS1-Voltage-Cross-Section

- 预制式 Pre-molded:  
单芯户外终端 WTYZ-1-电压-截面  
Single-core Outdoor Termination: WTYZ-1-Voltage-Cross-Section
- 单芯户内终端 NTLIS1-电压-截面  
Single-core Indoor Termination: NTLIS1-Voltage-Cross-Section

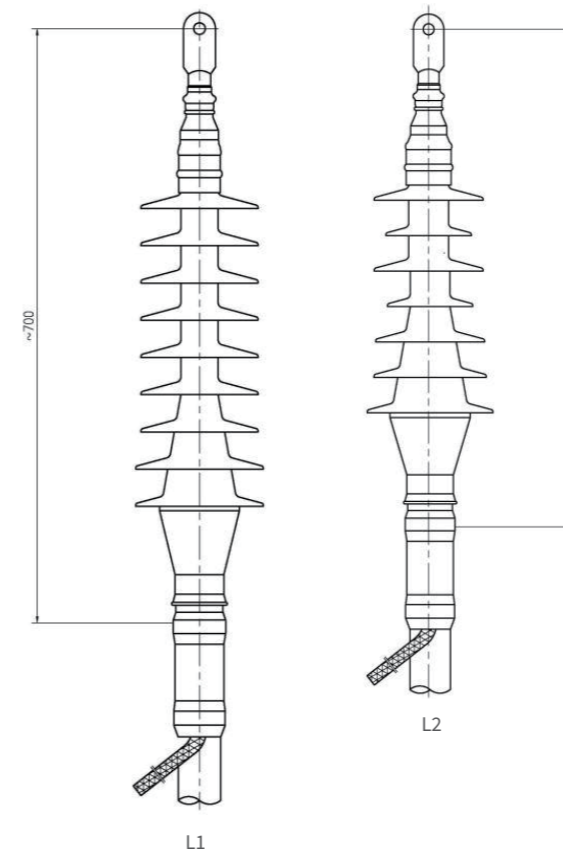

户内终端外形尺寸  
Indoor Termination Outline Dimensions

电压等级 Voltage Classes	27.5/48kV	
适用地点 Application Location	户外 Outdoor	户内 Indoor
L <sub>1</sub> mm	~200	~400
L <sub>2</sub> mm	~400	~650

### 风电场用电缆附件 Cable Accessories for Wind Power Plant Applications

产品利用高弹性体材料在工厂内注射硫化成型,再经扩径,衬以塑料螺栓支撑物构成。现场安装时将这些预扩张件再处理后电缆末端或接头处,抽出内部支撑物,套紧再电缆绝缘上。

Manufactured via injection molding and vulcanization of high-elasticity materials in the factory, the product is expanded and supported by plastic bolt spacers. During on-site installation, these pre-expanded components are prepared and fitted onto cable ends or joints; the internal supports are then removed, allowing the components to shrink tightly onto the cable insulation.

#### 产品型号

#### Product Models

风用电缆附件 Cable Accessories for Wind Power	电压等级 Voltage Classes	使用场景 Application Scenario
发电伊始 Power Generation Stage	1.8/3kV	1kV电缆与变压器 低压侧之间 Between 1kV cables and transformer low-voltage sides
电能输送 Power Transmission Stage	35kV	变压器高压侧与 35kV电缆之间 Between transformer high-voltage sides and 35kV cables

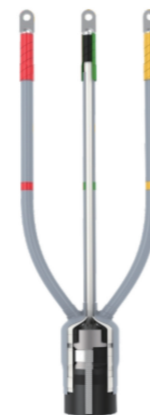

#### 冷缩电缆附件

#### Cold-shrink Cable Accessories

- 适用交联聚乙烯 (XLPE) 或乙丙橡胶 (EPR) 绝缘电缆  
Suitable for cross-linked polyethylene (XLPE) or ethylene propylene rubber (EPR) insulated cables.
- 终端为整体式结构,能快速安装和使用于多种电缆  
Integral termination structure enables quick installation and compatibility with various cable types.
- 采用纳米改性硅橡胶材料,增强了终端表面疏水性,材料耐老化,耐盐雾性能优异  
Adopts nano-modified silicone rubber, enhancing surface hydrophobicity with excellent aging resistance and salt spray resistance.

#### 电缆中间接头

#### Cable Intermediate Joints

- 电缆中间接头本体部分提供了电场控制,绝缘恢复,外屏蔽层恢复,而且以上各部分内屏蔽,外屏蔽,增强绝缘和应力控制部分工厂一体成型,相互间无分层和气隙,质量稳定可靠。  
The joint body integrates electric field control, insulation restoration, and outer shielding layer restoration. Its inner shielding, outer shielding, reinforced insulation, and stress control components are integrally molded in the factory, free of delamination and air gaps, ensuring stable and reliable quality.
- 接头主体采用进口硅橡胶,德国德斯玛设备加工成型,加工产品精度高,产品经过了长期运行考验。  
The joint body is made of imported silicone rubber, processed and formed by German Desma equipment, featuring high precision and proven long-term operational reliability.



### 铁路、风电场用可分离连接器

#### Separable Connectors for Railway and Wind Power Plant Applications

#### 产品符合

#### Complies with

- EN50181《不包括充液变压器在内的设备用1kV至36kV,250A至1250A的插入式套管》  
EN 50181 Plug-in Bushings for Equipment Other Than Fluid-Filled Transformers – Rated Voltages from 1kV to 36kV and Rated Currents from 250A to 1250A
- GB/T28427《电气化铁路27.5kV单相交流交联聚乙烯绝缘电缆及附件》  
GB/T 28427 27.5kV Single-phase AC Cross-linked Polyethylene (XLPE) Insulated Cables and Accessories for Electrified Railways

#### 适用范围

#### Application Scope

额定电压 Rated Voltage:26/35kV  
适用截面 Applicable Cross-Section:50~630mm<sup>2</sup>  
海拔高度 Altitude:0~4500m  
环境温度 Ambient Temp:-40~+45°C

#### 产品型号

#### Product Model

CB-NZ

#### 产品特点

#### Product Features

- 整体预成型复合内锥选用进口硅橡胶材料,绝缘性能优良  
The fully pre-molded composite inner cone is made of imported silicone rubber, delivering excellent insulation performance.
- 外壳材料为高强度铝合金  
The housing is constructed from high-strength aluminum alloy.
- 产品设计为可插拔结构,安装方便  
Designed with a plug-in structure for easy installation.

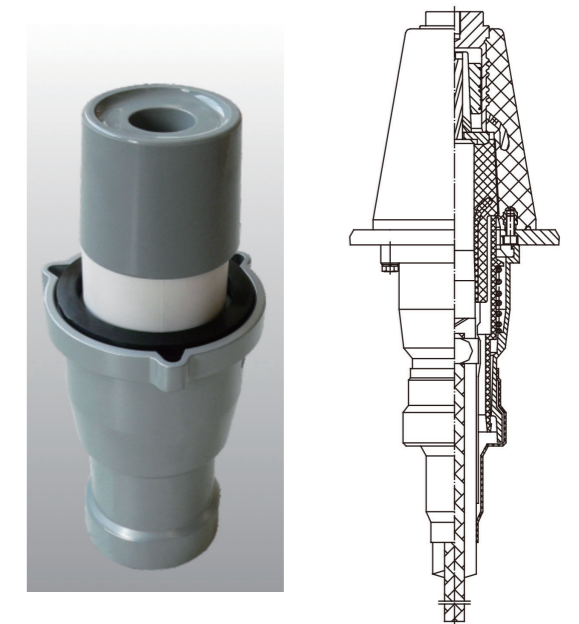

电缆管封堵器  
Cable Pipe Sealers

随着我国的经济高速发展,城市基建逐步完善,对地下管线的建设也提出了更高的要求。处于地下的电缆在管理上十分不方便,进出电缆经常被雨水浸泡,或者被老鼠啃噬咬断,造成漏电、断电等严重后果。而在做地下防水工程时,如果设计欠合理,构造处理不妥,选材马虎,会直接影响施工质量。遇上地基下沉或是天灾人祸等诸多不可预计的因素影响,导致正在施工或已竣工的工程发生液体泄漏的严重现象,而渗液的主要危害是容易腐蚀隧道内部的钢筋混凝土,造成结构松动导致坍塌,因此做好电缆管道封堵非常重要。

With China's rapid economic growth and improved urban infrastructure, higher standards have been set for underground pipeline construction. Underground cables are challenging to manage: cable entries/exits are often exposed to rainwater immersion or rodent damage, leading to critical issues like leakage or power outages. For underground waterproofing works, poor design, improper structural handling, or substandard material selection directly compromises construction quality. Unforeseen factors (e.g., foundation settlement, accidents) can cause liquid leakage in ongoing or completed projects; such leakage risks corroding reinforced concrete in tunnels, leading to structural loosening and collapse. Thus, reliable cable pipe sealing is essential.

产品选型表 Product Selection Table

YJ系列电缆管封堵器产品型号规格  
YJ Series Cable Pipe Sealer Models & Specifications

产品型号 Product Model	外形尺寸 Overall Dimensions (mm)	产品内/外径 Product Inner/Outer Diameter (mm)	适用管内径 Applicable Pipe Inner Diameter (mm)	适用线径 Applicable Wire Diameter
YJ-50	96×95	45/55	40-50	20-30
YJ-75	130×110	68/75	60-70	25-32
YJ-110	168×113	66/96	96-106	40-66
YJ-160	130×110	92/130	130-155	54-92
YJ-180	152×110	105/152	152-175	73-105
YJ-200	168×113	120/168	168-195	78-120
YJ-225	195×120	144/195	195-220	93-144
YJ-280	245×150	156/245	245-260	102-156

产品外形图 Product Outline Drawing

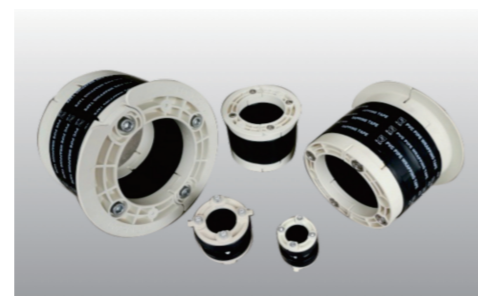

电缆井现场使用图  
Cable Manhole On-Site Application Diagram

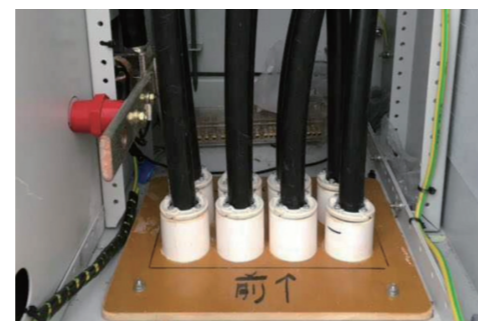

电器柜现场使用图  
Electrical Cabinet On-Site Application Diagram

自固化绝缘防水保护材料  
Self-Curing Insulating & Waterproof Protective Material

产品简介 Product Introduction

自固化绝缘防水保护包材(YJJBC)是为10kV架空裸导线绝缘及绝缘线路裸露点绝缘和防水防护而设计的可快速施工并能室温固化的特殊带状片材。固化前的YJJBC材质具备一定的初始强度、优良的自熔性能和优异的贴附/从形性能;固化后的YJJBC具备优良的绝缘性能,优异的弹性,突出的耐UV性能,对金属具有良好的贴附性及附着力,良好的耐热和阻燃性能;YJJBC不仅可用于架空线的防护,也可用于线夹,裸露电气连接点的防护,以进一步提高电力系统的稳定性。

The Self-Curing Insulating & Waterproof Protective Wrap (YJJBC) is a specialized tape-like sheet designed for insulation and waterproofing of 10kV overhead bare conductors and exposed points of insulated lines. It enables fast on-site installation and cures at room temperature.

Before curing: YJJBC has sufficient initial strength, excellent self-fusing properties, and superior conformability. After curing: YJJBC delivers excellent insulation performance, high elasticity, outstanding UV resistance, strong adhesion to metal surfaces, and good heat resistance & flame retardancy.

YJJBC is suitable not only for overhead line protection but also for safeguarding line clamps and exposed electrical connection points, helping to enhance the stability of power systems.

产品外形图 Product Outline Drawing

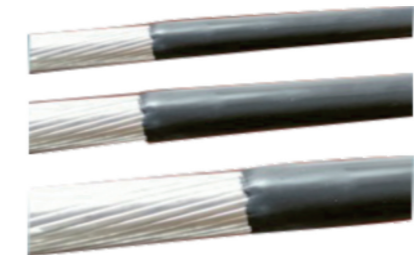

YJJBC绝缘包材用于-母牌  
YJJBC Insulating Wrap for Busbars



YJJBC绝缘包材用于-裸露导线  
YJJBC Insulating Wrap for Exposed Conductors



现场使用图 On-Site Application Diagram

## 工程案例 Engineering Case

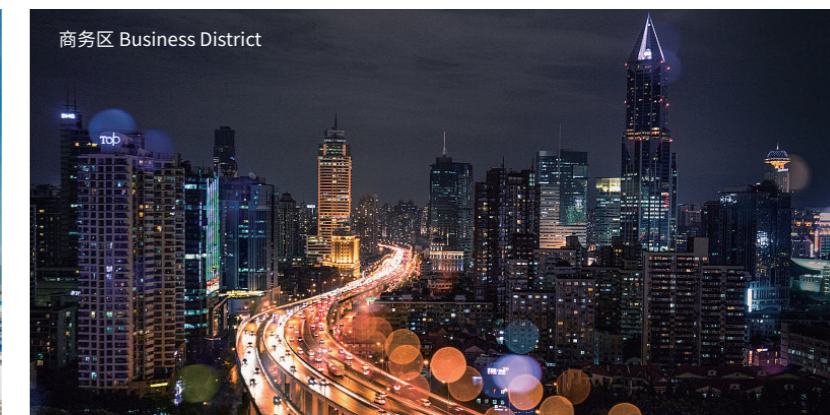



---

**EONGE 永锦电气**  
专注电力 服务全球  
FOCUS ON POWER · SERVE THE WORLD